

NOTICE: This document contains information of a preliminary nature and is not intended for release. It is subject to revision or correction and therefore does not represent a final report.



# Sensing and Measurement Technology Roadmap

Devices Including Communications and Data  
Analytics Requirements

February 2019

D. Tom Rzy, PI  
Paul Ohodnicki, PlusOne  
GMLC Sensing & Measurement Strategy Project Team

## DOCUMENT AVAILABILITY

Reports produced after January 1, 1996, are generally available free via US Department of Energy (DOE) SciTech Connect.

**Website** [www.osti.gov](http://www.osti.gov)

Reports produced before January 1, 1996, may be purchased by members of the public from the following source:

National Technical Information Service  
5285 Port Royal Road  
Springfield, VA 22161  
**Telephone** 703-605-6000 (1-800-553-6847)  
**TDD** 703-487-4639  
**Fax** 703-605-6900  
**E-mail** [info@ntis.gov](mailto:info@ntis.gov)  
**Website** <http://classic.ntis.gov/>

Reports are available to DOE employees, DOE contractors, Energy Technology Data Exchange representatives, and International Nuclear Information System representatives from the following source:

Office of Scientific and Technical Information  
PO Box 62  
Oak Ridge, TN 37831  
**Telephone** 865-576-8401  
**Fax** 865-576-5728  
**E-mail** [reports@osti.gov](mailto:reports@osti.gov)  
**Website** <http://www.osti.gov/contact.html>

This report was prepared as an account of work sponsored by an agency of the United States Government. Neither the United States Government nor any agency thereof, nor any of their employees, makes any warranty, express or implied, or assumes any legal liability or responsibility for the accuracy, completeness, or usefulness of any information, apparatus, product, or process disclosed, or represents that its use would not infringe privately owned rights. Reference herein to any specific commercial product, process, or service by trade name, trademark, manufacturer, or otherwise, does not necessarily constitute or imply its endorsement, recommendation, or favoring by the United States Government or any agency thereof. The views and opinions of authors expressed herein do not necessarily state or reflect those of the United States Government or any agency thereof.

“This research was supported by the Grid Modernization Initiative of the U.S. Department of Energy as part of its Grid Modernization Laboratory Consortium, a strategic partnership between DOE and the national laboratories to bring together leading experts, technologies, and resources to collaborate on the goal of modernizing the nation’s grid.”

Sustainable Electricity Program

**SENSING AND MEASUREMENT TECHNOLOGY ROADMAP**

**INCLUDING COMMUNICATIONS AND DATA ANALYTICS REQUIREMENTS**

**GMLC PROJECT 1.2.5 SENSING AND MEASUREMENT STRATEGY PROJECT**

Author(s)

D. Tom Rizy, ORNL, PI

Paul Ohodnicki, NETL, PlusOne and Task Coordinator

Project Team Key Contributors: Zhi Li (ORNL), Emma Stewart (LLNL), Sydni Credle (NETL), Yarom Polsky (ORNL), Paul Ohodnicki (NETL), Olga Lavrova (SNL), Venkat Krishnan (NREL), Guodong Liu (ORNL), Peter Fuhr (ORNL), Chen (ANL), Emma Stewart (LLNL), Philip Top (LLNL), Matthew Lave (SNL), and Steven Bossart (NETL).

Date Published: February 2019



Prepared by  
OAK RIDGE NATIONAL LABORATORY  
Oak Ridge, TN 37831-6283  
managed by  
UT-BATTELLE, LLC  
for the  
US DEPARTMENT OF ENERGY  
under contract DE-AC05-00OR22725



# CONTENTS

<b>PREFACE</b> .....	<b>v</b>
<b>ABBREVIATIONS, ACRONYMS, AND INITIALISMS</b> .....	<b>vii</b>
<b>ACKNOWLEDGEMENTS</b> .....	<b>ix</b>
<b>1. EXECUTIVE SUMMARY OF THE KEY RECOMMENDATIONS</b> .....	<b>1</b>
<b>1.1 CROSSCUTTING SENSING AND MEASUREMENT SUPPORT</b> .....	<b>3</b>
<b>1.2 USES AND SENSING TECHNOLOGY TARGETS</b> .....	<b>1</b>
<b>1.3 COMMUNICATION AND NETWORKS</b> .....	<b>2</b>
<b>1.4 DATA MANAGEMENT AND ANALYTICS INCLUDING GRID MODELING</b> .....	<b>3</b>
<b>2. TECHNOLOGY ROADMAP ORGANIZATION</b> .....	<b>5</b>
<b>3. BACKGROUND AND CONTEXT</b> .....	<b>6</b>
<b>4. SENSING AND MEASUREMENT IN THE GMI</b> .....	<b>8</b>
<b>5. GMLC SENSING AND MEASUREMENT STRATEGY PROJECT</b> .....	<b>12</b>
<b>6. SENSOR AND MEASUREMENT TECHNOLOGY ROADMAP PROCESS</b> .....	<b>16</b>
<b>7. TECHNOLOGY REVIEW AND ASSESSMENT DOCUMENT FINDINGS</b> .....	<b>22</b>
<b>8. WORKING GROUP GAP ANALYSIS RESULTS SUMMARY</b> .....	<b>25</b>
<b>8.1 USES AND SENSING TECHNOLOGY TARGETS</b> .....	<b>25</b>
<b>8.1.1 Issues to Monitor</b> .....	<b>25</b>
<b>8.1.2 Advanced Materials and Techniques</b> .....	<b>26</b>
<b>8.1.3 Needed Advancements</b> .....	<b>26</b>
<b>8.2 COMMUNICATION AND NETWORKS</b> .....	<b>30</b>
<b>8.2.1 Utilization and Integration</b> .....	<b>30</b>
<b>8.2.2 Architecture</b> .....	<b>31</b>
<b>8.2.3 Standards and Protocols</b> .....	<b>31</b>
<b>8.3 Data Management and Analytics Including Grid Modeling</b> .....	<b>33</b>
<b>8.3.1 Data Management</b> .....	<b>33</b>
<b>8.3.2 Data Analytics</b> .....	<b>34</b>
<b>9. CROSSCUTTING ISSUES</b> .....	<b>38</b>
<b>9.1 CYBER-PHYSICAL</b> .....	<b>38</b>
<b>9.2 STANDARDS, TESTING, AND STANDARDIZATION</b> .....	<b>38</b>
<b>9.3 VALUE PROPOSITION</b> .....	<b>38</b>
<b>9.4 FACILITATING DEPLOYMENT OF NEW TECHNOLOGIES</b> .....	<b>39</b>
<b>10. CROSSCUTTING SENSING AND MEASUREMENT SUPPORT</b> .....	<b>43</b>
<b>10.1 CYBER-PHYSICAL SECURITY AWARENESS AND SUPPORT</b> .....	<b>43</b>
<b>10.2 STANDARDS AND TESTING TO SUPPORT IMPROVEMENT OF SENSOR PERFORMANCE, RELIABILITY, RESILIENCY, AND INTEROPERABILITY</b> .....	<b>44</b>
<b>10.3 VALUATION OF SENSING AND MEASUREMENT TECHNOLOGY</b> .....	<b>45</b>
<b>10.4 GENERAL CROSSCUTTING NEEDS SUPPORT FOR INDUSTRY AND UTILITY PARTNERS IN TECHNOLOGY DEPLOYMENT</b> .....	<b>46</b>
<b>11. HIGH-VALUE USE CASES AND THE EXTENDED GRID STATE DEFINITION</b> .....	<b>48</b>
<b>11.1 FAULT DETECTION, INTERRUPTION AND SYSTEM RESTORATION</b> .....	<b>48</b>
<b>11.2 INCIPIENT FAILURE DETECTION IN ELECTRICAL GRID ASSETS</b> .....	<b>49</b>

11.3	<b>SENSING AND MEASUREMENT TECHNOLOGY TO MITIGATE AGAINST IMPACTS OF NATURAL DISASTERS AND ENHANCE GRID RESILIENCE .....</b>	<b>52</b>
11.4	<b>SUMMARY OF USE CASES .....</b>	<b>52</b>
12.	<b>KEY FINDINGS AND PROPOSED FEDERAL EFFORTS TO ADDRESS GAPS.....</b>	<b>54</b>
12.1	<b>USES AND SENSING TECHNOLOGY TARGETS .....</b>	<b>54</b>
12.2	<b>COMMUNICATION AND NETWORKS.....</b>	<b>55</b>
12.3	<b>DATA MANAGEMENT AND ANALYTICS INCLUDING GRID MODELING.....</b>	<b>56</b>
13.	<b>PROPOSED RESEARCH THRUSTS INCLUDING METRICS .....</b>	<b>58</b>
	<b>APPENDIX A. DEFINITIONS.....</b>	<b>A-1</b>
	<b>APPENDIX B. CYBER-PHYSICAL SECURITY .....</b>	<b>B-1</b>
	<b>APPENDIX C. SENSOR AND MEASUREMENT TECHNOLOGY ROADMAP PROCESS .....</b>	<b>C-1</b>
	<b>APPENDIX D. WORKING GROUP REPORT SUMMARIES.....</b>	<b>D-1</b>
	<b>APPENDIX E. USE CASES.....</b>	<b>E-1</b>

## PREFACE

This report was prepared by the Grid Modernization Lab Consortium Sensing and Strategy Project Team for task 2 (sensor technology R&D roadmap development).

### **Principal Investigator:**

D. Tom Rizy, Oak Ridge National Laboratory (ORNL)

Email: [dtom@ornl.gov](mailto:dtom@ornl.gov)

Phone: (865) 574-5203

### **PlusOne and Task 2 Lead:**

Paul Ohodnicki, National Energy Technology Laboratory (NETL)

Email: [paul.ohodnicki@netl.doe.gov](mailto:paul.ohodnicki@netl.doe.gov)

Phone: (412) 386-7389

### **GMLC Sensor Area Lead:**

Tom King, Oak Ridge National Laboratory

Email: [kingtj@ornl.gov](mailto:kingtj@ornl.gov)

Phone: (865) 241-5756

### **DOE Laboratory Working Group Leads:**

*Crosscutting Sensing and Measurement Support:* Zhi Li (ORNL)

*Use Case Refinement and Extended Grid State Integration:* Emma Stewart (LLNL)

*Harsh Environment Sensors for Flexible Generation:* Sydney Credle (NETL)

*Phasor Measurement Units for Grid State and Power Flow:* Yarom Polsky (ORNL)

*Asset Health Monitoring:* Paul Ohodnicki (NETL)

*Novel Transducers:* Olga Lavrova (SNL)

*Sensors for Weather Monitoring and Forecasting:* Venkat Krishnan (NREL)

*End-Use/Buildings Monitoring:* Guodong Liu (ORNL)

*Distributed Architectures:* Peter Fuhr (ORNL)

*Communications Technology:* Chen Chen (ANL)

*Advanced Analytics:* Emma Stewart (LLNL)

*Big Data:* Philip Top (LLNL)

Other members and participants of the project are identified in the appendix.



## ABBREVIATIONS, ACRONYMS, AND INITIALISMS

AGC	automatic generation controller
ANL	Argonne National Laboratory
CA	California
CIP	Critical Infrastructure Protection (NERC standard)
DER	distributed energy resource
DGA	dissolved gas analysis
DHI	diffuse horizontal irradiance
DNI	direct normal irradiance
DOE	US Department of Energy
EGS	extended grid state
EERE	Office of Energy Efficiency and Renewable Energy
EPRI	Electrical Power Research Institute
ES	energy storage
FDD	fault detection and diagnosis
GHz	gigahertz
GHI	global horizontal irradiance
GMLC	Grid Modernization Lab Consortium
GMI	Grid Modernization Initiative
GPS	geographic positioning system
ICS	incident command system
IEEE	Institute of Electrical and Electronics Engineers
IIoT	Industrial Internet of Things
INL	Idaho National Laboratory
IoT	Internet of Things
ISO	independent system operator
IT	information technology
ITC	information technology and communications
kWh	kilowatt hour
LANL	Los Alamos National Laboratory
LBNL	Lawrence Berkeley National Laboratory
LED	light-emitting diode
LLNL	Lawrence Livermore National Laboratory
MHz	megahertz
MWh	megawatt hour
MYPP	Multi-Year Program Plan
NASPI	North American Synchrotron Initiative
NERC	North American Electricity Reliability Corporation
NETL	National Energy Technology Laboratory
NFV	network function virtualization
NREL	National Renewable Energy Laboratory

ORNL	Oak Ridge National Laboratory
O&M	operations and maintenance
OE	Office of Electricity
OT	operational technology
PMU	phasor measurement unit
PNNL	Pacific Northwest National Laboratory
POA	plane of array
p.u.	per unit
PV	photovoltaic
PWST	passive wireless sensor technology
QoS	quality of service
R&D	research and development
RMS	root-mean squared
ROCOF	rate of change of frequency
SCADA	supervisory control and data acquisition
SDN	software-defined networking
SNL	Sandia National Laboratories
SPOT	sensor placement optimization tool
T&D	transmission and distribution
THD	total harmonic distortion
UAV	unmanned aerial vehicle

## ACKNOWLEDGEMENTS

This report was sponsored by the US Department of Energy (DOE) Office of Electricity (OE) and the Office of Energy Efficiency and Renewable Energy (EERE). The project was directed and supported by DOE Program Managers Kerry Cheung of OE and Marina Sofos of EERE.

The Grid Modernization Lab Consortium (GMLC) Sensing and Measurement Strategy Project, which involved multiple national laboratory team members, was led by Oak Ridge National Laboratory. The task 2 effort, which involved the development of (1) a technical review document on the state of the art in sensors<sup>1</sup> and (2) a document (this report) on sensor technology research and development needs was led by the task lead at the National Technology Energy Laboratory.

Working groups consisting of national laboratory personnel and industry members were formed to expedite the development of this document. The working groups and their laboratory leads played a valuable role in the development of this roadmap.

Industry partners and stakeholders that are identified later in this report graciously volunteered their time and effort to work with the GMLC project team. They provided valuable input and review comments on various drafts of the report. They also attended multiple webinars, working group meetings, and industry meetings to provide this industry perspective for the roadmap.

The GMLC has three sensor projects, of which the GMLC Sensing and Measurement Strategy is one. The other two are Advanced Sensors, and Data Analysis and Machine Learning. Tom King, who is the lead for all of these sensor projects, provided guidance to the project leads and team during the development of this roadmap.

We would like to thank Alfonso Tarditi of ORNL's Power and Energy Systems Group and Tim McIntyre of ORNL's Sensors and Embedded Systems Group for their technical reviews of the draft document. Also, we would like to thank Deborah Counce of ORNL's Technical Communications Group for her thorough technical editing of the document, as well as Michael Gipple and Jennifer Bowman of NETL's Technical Writing and Multimedia group for formatting, technical review, and graphical support.

---

<sup>1</sup> Review and Assessment of Sensing and Measurement Technology for Electric Grids, Devices Including Communications and Data Analytics Requirements, ORNL/SPR-2018/956, December 2018, prepared by the GMLC Sensing & Measurement Strategy Project (PI: D. Tom Rizy, Task Lead: Paul Ohodnicki) and posted on the GMLC website at <https://gridmod.labworks.org/resources>.



## 1. EXECUTIVE SUMMARY OF THE KEY RECOMMENDATIONS

The Sensing and Measurement Strategy Project is a foundational effort of the Grid Modernization Laboratory Consortium (GMLC), spurred by the greater need for observability of the electric power grid in the future. The *GMLC Sensing and Measurement Technology Roadmap* Report was developed as a collaboration across the Department of Energy (DOE) national laboratory system in close partnership with key partners and stakeholders from industry, academia, and other relevant government organizations. The intent of the Roadmap is to establish a set of goals and needs for sensing and measurement, identify a set of specific technology solution recommendations anticipated to meet those goals, and lay out a path to deliver those recommended solutions for meeting the goals of the Grid Modernization Initiative (GMI). The GMLC Sensing and Measurement Roadmap effort has been carried out as an iterative process that summarizes the current state of the art of sensor and measurement technology<sup>2</sup>, outlines existing gaps, and points toward potential areas of need and opportunity for federal investment to make a significant impact. The Roadmap can serve as a living document based upon regular updates and improvements (i.e., every few years) through ongoing stakeholder feedback and engagements in collaboration with DOE.

The Roadmap identifies a number of strategic focus areas and research thrusts spanning the areas of (1) advanced sensing and measurement devices, (2) network communications, and (3) data management and analytics that can meet the observability needs of current and future power systems. The Roadmap also outlines a set of high-value use cases that can demonstrate tangible benefit and beneficial impact for the broad range of new sensing and measurement technologies being developed and deployed. The Roadmap also addresses crosscutting sensing and measurement issues and recommends a set of crosscutting support efforts to accelerate the deployment, implementation, and impact of advanced sensing and measurement technologies within the modern power system. Finally, the Roadmap reflects on a new architectural definition for the modern grid called the “extended grid state” (EGS)<sup>3</sup>, which expands the reach of the power system to all of the modern assets interconnecting with the power system, including renewable energy sources, energy storage, electric vehicles, responsive loads, and others.

### 1.1 USES AND SENSING TECHNOLOGY

A number of gaps identified by the team involve (1) specific parameters that require improved visibility through advanced sensor device technology development, (2) needs for enabling technology development (e.g. low-cost manufacturing, sensor materials) to support the successful realization of advanced sensor devices, and (3) characteristics needed by advanced sensor device technologies. Based on these identified gaps, the team made a number of recommendations, around which a number of research thrusts were identified. The following are specific areas of focus recommended for achieving targets set by federal initiatives seeking to accomplish the goals of the grid modernization initiative. Direct digitally printed passive wireless sensor technology (PWST) may address most. Detailed targets for specific technology development efforts including performance and cost metrics as well as recommendations for prioritization, are included within the body of the roadmap.

1. Dramatic reductions in cost for devices with similar performance to existing sensor devices, as well as extremely low-cost sensing approaches with reduced but adequate overall performance to enable wider deployment and greater system, particularly in distribution systems where lower

---

<sup>2</sup> Review and Assessment of Sensing and Measurement Technology for Electric Grids, Devices Including Communications and Data Analytics Requirements, ORNL/SPR-2018/956, December 2018, prepared by the GMLC Sensing & Measurement Strategy Project (PI: D. Tom Rizy, Task Lead: Paul Ohodnicki) and posted on the GMLC website at <https://gridmod.labworks.org/resources>.

<sup>3</sup> *Extended Grid State Definition Report*, prepared by the GMLC Sensing & Measurement Strategy Project, PI: D. Tom Rizy, Task Lead: Jeff Taft, Version 3.2 current draft, to be published as a PNNL and GMLC Report.

cost assets reside, with resultant benefits in terms of overall electrical system resiliency and reliability. For example, ultra-low-cost, proxy-based sensing platforms (e.g., acoustics, vibration) can serve as substitutes for direct monitoring of hard-to-measure parameters (e.g. partial discharge).

2. High-temperature and harsh-environment sensing platforms for monitoring conventional generation assets to improve reliability and efficiency in light of the needs for greater generation cycling (ramping up/down of power output) in a modern power system with greater penetration of variable renewable resources (wind and solar); both utility scale as well as distributed energy resources (DER) primarily connected to distribution system.
3. Enabling materials and manufacturing technologies such as advanced sensor materials, new packaging materials or techniques, and advanced manufacturing to enable new lower-cost sensing platforms not currently possible with conventional manufacturing techniques.
4. Temperature and chemical (e.g., dissolved gas analysis or DGA) sensing approaches for internal monitoring of electrical grid and generation assets for enhanced ability to predict incipient failures of grid assets at the distribution level before they occur.
5. High-bandwidth, low-latency electrical parameter measurements, including frequency-selective sensors for increased capability to identify abnormalities in electrical systems and assets quickly and with sufficient time to enable dynamic protection schemes.
6. Sensor platforms that provide (a) multi-parameter capability, (b) compatibility with deployment internal to electrical and generation assets, and (c) capability for spatially distributed measurements to enable a suite of sensing technologies with optimized trade-offs in performance, cost, and spatial characteristics. In this way the value of a given sensor placement can be matched with the associated cost and value for deployment at the distribution or transmission level.
7. Wireless, self-powered, and/or passive, self-configuring, and self-calibrating sensors to enable future transactive controls among other grid monitoring applications.
8. Optimal identification of new and existing weather monitoring infrastructures for advanced renewable energy (including DER) forecasting and integration into system control centers, and extraction of value streams from variable renewables to enhance resilience against natural disasters.

## **1.2 COMMUNICATION AND NETWORKS**

Communication-related gaps could be clearly linked to (1) the need for optimized spectrum utilization and ease of integration of new technology platforms into various communications networks, (2) overall architecture characteristics, and (3) the need for standards as well as protocols for communication and networking technology. Based on these identified gaps, the team made a number of recommendations, around which a number of research thrusts were identified. The following are specific areas of focus recommended for achieving targets set by federal initiatives seeking to accomplish the goals of the grid modernization initiative. Detailed targets including performance and cost metrics as well as recommendations for prioritization, are included within the body of the roadmap.

1. Design and develop a cost-effective, scalable communications fabric to support the wide range of next-generation sensors, systems, and DER or DER components under investigation.

2. Design and continue to implement a distributed communications architecture that addresses the challenges surrounding new technology developments, such as the Industrial Internet of Things and 5G wireless.
3. Develop a scalable, rapid speed, high-bandwidth, and low-latency communications network to support cyber-secure transport of data associated with electrical parameter measurements.
4. Address spectrum utilization challenges through distributed scheduling schemes and distributed intelligence, for example, as well as dynamic spectral resource allocation.
5. Quantify uncertainties and security risks of communication systems in the context of the modern electric power system and develop self-healing and more robust capabilities to oppose malicious operations in response to increasing concerns about cyber-physical security.

### **1.3 DATA MANAGEMENT AND ANALYTICS INCLUDING GRID MODELING**

Gaps could be clearly linked to (1) data management, standards, and utilization as well as (2) data analytics technique development, applications for grid modeling, operations and real-time security assessments, and deployment. Based on these identified gaps, a number of recommendations were made and a number of related research thrusts were identified. The following are specific areas of focus recommended for achieving targets set by federal initiatives seeking to accomplish the goals of the grid modernization initiative. Detailed targets including performance and cost metrics as well as recommendations for prioritization, are included within the body of the roadmap.

1. Specifically focus data management in the utility sector on addressing three gaps: cost justification, workforce education, and standardization.
2. Simplify human-machine interactions with advanced data management and analytical tools, both visualization tools and user interfaces, to accelerate implementation by utilities, for example, by engaging operators throughout the research and development process.
3. Standardize data formats and interfaces and develop and apply techniques for data quality monitoring in real time. Consider a consortium for data standardization through the GMLC.
4. Develop and apply data analytics methods, including distributed data analytics, which enable the coupling of spatially dispersed sensors of varying types to accomplish desired electric power system objectives.

### **1.4 CROSSCUTTING SENSING AND MEASUREMENT SUPPORT**

A clear need exists for foundational efforts to support the successful technology development and deployment of advanced sensing and measurement tools and methodologies throughout the electrical grid infrastructure. **A recommendation is made to establish a Crosscutting Sensing and Measurement Support effort that spans the various research thrusts and initiatives outlined in more detail in subsequent sections of the Roadmap.** The objective of this crosscutting effort is three-fold: (1) To raise awareness of the identified issues that are common across different sensing and measurement areas. (2) To create a gateway for stakeholders to efficiently access the right expertise and resources to address the issues and to share lessons learned. (3) To provide necessary support, technical or nontechnical, to facilitate the first two efforts. As a result, the crosscutting area should (1) provide a voice for the utility industry regarding challenges it faces in deploying and leveraging new sensing and measurement

technologies, (2) provide tools to enable clear valuations of various sensing and measurement technologies, and (3) collate and clarify the costs and reliability of existing and emerging solutions.

Based on the crosscutting issues and needs identified in the working group process, four crosscutting initiatives are recommended:

1. Cyber-physical security awareness and support
2. Standards and testing to support improvement of sensor performance, reliability, resiliency, and interoperability
3. Evaluation methods for determining valuation (costs, benefits, strengths) of sensing and measurement technology

General crosscutting needs support for industry and utility partners in technology deployment

## 2. TECHNOLOGY ROADMAP ORGANIZATION

The remainder of the GMLC Sensing & Measurement Technology Roadmap (identified going forward in the text as the Roadmap) is organized into the following sections:

- Background and Context
- Sensing and Measurement in the GMI
- GMLC Sensing and Measurement Strategy Process
- Sensor and Measurement Technology Roadmap Process
- Technology Review and Assessment Report Findings
- Working Group Gap Analysis Results Summary
- Crosscutting Sensing and Measurement Support
- High-Value Use Cases and the Extended Grid State Definition
- Key Findings and Federal Efforts to Address Gaps
- Proposed Research Thrusts Including Metrics
- Appendices A–E

More detailed information about the current state of the art in regard to sensing and measurement, as well as existing programmatic activities and efforts, can be found in the Sensing and Measurement *Technology Review and Assessment Report*.<sup>4</sup>

---

<sup>4</sup> Review and Assessment of Sensing and Measurement Technology for Electric Grids, Devices Including Communications and Data Analytics Requirements, ORNL/SPR-2018/956, December 2018, prepared by the GMLC Sensing & Measurement Strategy Project (PI: D. Tom Rizy, Task Lead: Paul Ohodnicki) and posted on the GMLC website at <https://gridmod.labworks.org/resources>.

### 3. BACKGROUND AND CONTEXT

Historically, the electric power grid has been a fully controlled system in which central generation operated to deliver power via the transmission and distribution system to meet and follow the end-user load; in that sense, therefore, the system was a highly predictable network. Electricity was generated in centralized power generation plants and transported through high-voltage transmission and lower-voltage distribution lines to end-use industrial, commercial, and residential customers. Utilities owned all of these assets and managed generation output to follow the customer's load demand and maintain system frequency. Those times have changed significantly.

In recent years, the power system has become significantly more complicated, with more independent but interdependent actors and changes in asset ownership. An increasing number of utility-scale generators are now owned and operated by independent generation owners and operators. The mix of generation technologies also has changed and is continuing to do so drastically, to include more renewable energy sources and energy storage. Moreover, many customers no longer are just consumers of electricity but also now own and/or operate small distributed generators connected to the distribution system. Independent grid operators now operate competitive wholesale power markets and dispatch electric power delivery operations in two-thirds of the nation. Natural gas-fired generation is displacing many coal plants as a result of clean air and environmental concerns and displacing nuclear power plants because of the high cost of completing and maintaining them. As a result, customer end-use demand, and even power generation, is no longer as predictable as it used to be, because customer loads vary as a result of on-site renewable generation and power generation at renewable power plants may fluctuate with weather conditions. Operational challenges include more diverse and complicated components (such as electronics, automated controls, renewable generation, and aging generation and power delivery assets), and more complex, dynamic, hard-to-predict behaviors (such as power system oscillations). As a result, grid conditions can change quickly, requiring better sensing and measurements along with associated communications and data analytics and faster controls.

Power systems continue to be highly reliable but are now operating much closer to their operational limits with lower reserve margins (i.e., 15%) for resource adequacy. The “power system,” in its beginning, stretched from the power plant to the customer meter, including all assets in between. Today the power system extends far beyond utility control. It is affected by factors including the proliferation of “smart,” interconnected customer end-use devices (including electric vehicles; smart, thermostat-controlled heating, ventilation, and air-conditioning systems; and energy management system-controlled end uses) distributed generation and storage (e.g., solar photovoltaics, batteries, and back-up generators) throughout the utility; and many non-utility generation and storage assets.

Customers, society, and the economy place very high demands upon the power system and deservedly so—human, economic, and industrial health are highly dependent on highly reliable yet affordable grid power. At the same time, many stakeholders demand and expect clean, sustainable energy sources to ensure a clean environment. Furthermore, US dependence on reliable electric power will continue to grow, with greater use of electricity for transportation via electric cars and mass transportation, and for end-use consumer products including smart appliances and smart homes.

To meet these challenges, the US Department of Energy (DOE) launched the Grid Modernization Initiative (GMI) to identify and respond to the needs of the “modern grid” as well as its operators and planners. The GMI seeks to develop new grid architectural and planning concepts and new tools and technologies to measure, analyze, predict, operate, manage, control, and automate power system operations needed to transition to a smarter, reliable, resilient modern grid. The Grid Modernization Laboratory Consortium (GMLC) is a collaboration involving hundreds of millions of dollars from DOE to fund its national laboratories and industry in support of the GMI. DOE has funded the GMLC to

advance research, design, development, and applications to improve understanding of the power system and provide the tools and technologies needed for the operation and planning of the modern grid. Through the GMLC, DOE currently manages a large portfolio of research and development (R&D) projects in six R&D areas, including

- grid operations
- devices and testing
- design and planning
- security and resilience
- system operations and control
- sensing and measurement

Each of these six R&D areas has an extensive R&D portfolio of activities intended to accelerate the achievement of a resilient, secure, reliable, affordable, flexible, and sustainable modern grid.<sup>5</sup> The focus of this report is on the sensing and measurement area.

---

<sup>5</sup> The reader is encouraged to review source material for more information about the GMI and GMLC, in particular DOE's *Grid Modernization Multi-Year Program Plan* (November 2015), <https://www.energy.gov/downloads/grid-modernization-multi-year-program-plan-mypp>. That document lays out the changing demands upon the aging current US power system and the changes needed to modernize the grid.

#### 4. SENSING AND MEASUREMENT IN THE GMI

A major driver for GMI is the number of major past power system outages known to result from a lack of adequate situational awareness of grid conditions. Threats to the power system also have multiplied, including extreme weather events, cyber attacks, terrorist attacks, human errors, system errors, and aging assets and infrastructure. To address this problem, a major focus for the GMI is to improve measurement and monitoring of power system grid state and assets, in terms of performance health and capabilities. Better information and situational awareness allows more efficient, effective, and flexible grid control and operation and improves long-term, short-term, and real-time power system operational reliability and resiliency. For this reason, the sensing and measurement area of the GMLC is a core, foundational effort required to successfully realize the goals and objectives of the GMI and the modern grid.

The North American electric grid is going through a transformation to achieve GMI objectives of reducing outage costs by 10%, operational costs of reserve margins by 33%, and DER integration costs by 50%<sup>6</sup>. The traditional electric grid was designed and operated as a “load following” power delivery system with centralized generation that is controlled to meet and follow load demand and thus balance load and generation to keep the frequency of the grid stable at 60 Hz. High reliability of grid operation is achieved by monitoring assets, primarily at the generation and transmission level. Monitoring and control assets at the distribution level primarily observe and control substation-level equipment and power quality—including voltage and waveform distortions—to maintain viable voltage at the fundamental grid frequency.

The emergence of DERs (e.g., solar photovoltaic, wind, energy storage) can make the grid resilient through distributed control; but it also introduces new challenges for monitoring and control. To maximize the benefits of DER, grid parameters must be monitored at the generation, transmission, and distribution levels at a higher spatial and temporal resolution than ever before to ensure the safety of operators and optimal control of the complete system.

The objective of the sensing and measurement effort is to develop and deploy novel and advanced sensors at multiple levels of the grid in a cost-effective manner for rapid adoption. Currently, the power system uses multiple layers of sensors (e.g., electrical, mechanical, chemical), transducers (potential and current transformers), and actuators (e.g., breakers, capacitor banks, voltage regulators, reclosers). These sensors, transducers, and actuators monitor and control power flow, voltage level, and power quality from generation through the transmission and distribution (T&D) system to end loads. However, they are not integrated; are used in a localized fashion, primarily because of communication challenges; and often are expensive, especially for distribution systems, and thus are used only in niche applications. Thus, new R&D is needed to overcome the various technical and economic challenges of advanced sensor development, design, deployment and use.

Existing and emerging sensor solutions must balance three nonorthogonal dimensions of application, integration, and cost:

1. **Application requirements:** These are dictated by the optimal resolution and accuracy needs to support decision-making frameworks and applications in use by utilities and the broad range of other electric grid stakeholders.
2. **Integration requirements:** These are dictated by utility operational, planning, and regulatory frameworks with procedures for deploying new sensors into existing infrastructure with minimal

---

<sup>6</sup> Identified in the Grid Modernization Multi-Year Program Plan [MYPP].

disruption to power system reliability. They must also be integrated and interoperable with existing sensing, communications, and control infrastructures.

3. **Cost requirements:** The adoption of new technologies must be cost-effective throughout their entire life cycle including installation, maintenance, and calibration. In particular, integration with legacy electric grid assets drives sensor cost requirements, which differ at various levels of grid infrastructure (e.g., monitoring generation assets vs. transmission assets vs. distribution assets vs. end-use systems).

The increasing importance of power network **cybersecurity** requires new sensors to address cyber-physical security. Detecting and mitigating complex cyber threats to the power grid and its assets is an additional requirement that must be considered for new sensor installations.

Sensors represent both an opportunity and a risk for power system cybersecurity. On the positive side, sensors are critical instruments for detecting and mitigating cybersecurity threats to power system infrastructure. Sensors designed to measure and analyze communication systems are useful for intrusion detection and intrusion prevention systems. Unfortunately, sensors are also vulnerable to cyberattacks, including spoofing, denial of service, and man-in-the-middle attacks. A brief discussion of control system architectures used to describe the interactions between operational technology (OT) and information technology (IT) components of energy systems, as well as the intersection between advanced sensor technologies and cybersecurity as it relates to the electric power system, is provided in Appendix B. Within DOE, the Cybersecurity for Energy Delivery Systems Program’s roadmap for cybersecurity provides a robust intersection with GMLC sensing and measurement activities.<sup>7</sup>

Balancing application, integration, cost, and cyber-physical security requirements drives innovation in sensor development to meet targets in performance, cost, and deployment. Historically, sensor development inherently included the device-transducer, embedded computing for data processing, and end-to-end communication. Direct digital printing of passive wireless sensor technology (PWST) breaks this mold by employing very low-cost, battery-free sensor designs, combined with interrogators for data collection. The embedded computing is centralized at the interrogator rather than being replicated at every sensor node. This emerging PWST technology holds promise for drastic cost reductions by eliminating the two most costly elements of traditional sensor designs—embedded computing and the power source required to do the computing.

These novel sensor technologies must be developed to be appropriately scalable and reliable for utility adoption. By understanding vital parameters throughout the electric infrastructure, from generation through end-use, utilities will be able to assess grid health in real time, predict behavior, and detect potential disruptions; quickly respond to events; and better address future challenges. The key R&D challenges are to (1) develop and demonstrate novel sensors that improve observability of the electric grid at a very high resolution, and (2) use visibility to improve grid operation by reducing outages and improving reliability.

A sensor device typically includes all or a subset of the following four elements:

1. A *physical transducer* that converts the physical parameter measured (measurand) to an electrical signal for processing

---

<sup>7</sup> Individuals interested in examining the CEDS-sponsored projects may wish to visit <https://energy.gov/oe/cybersecurity-energy-delivery-systems-ceds-fact-sheets> where the individual fact sheets are available.

2. A *computational device*, typically a microprocessor or microcontroller, that converts the electrical signal from the transducer to digital information
3. A *communication device* that transmits the information over a wired or wireless network to a location for enabling data analytics and, ultimately, decision-making
4. A *power supply or system* that provides power to various elements of the sensor device

The convergence of the four key elements has occurred over decades to achieve a fully integrated sensor or measurement system. In recent times, this convergence has accelerated, partly because of increasing abilities for real-time data processing and analytics, along with consumer-grade manufacturability of ultra-low-power digital circuitry. These revolutionary developments fueled the growth of a large number of networked sensors called the “Internet of Things” (IoT). Information from these networked sensors has driven data analytics applications that can monitor data from a substantial number of heterogeneous data sources, infer complex underlying dynamics, present a diagnosis of the system behavior, and provide situational understanding for operators to make informed decisions.

**Innovation is required to develop fundamental sensor technology for improving grid operation along with deployment strategies that reduce the total costs of sensor installation and commissioning.**

All four of the sensor elements listed exist in PWST networks. The difference is that, in PWST networks, elements 2, 3, and 4 are found only in the interrogators and are not replicated at every sensor—significantly reducing sensor costs. PWST also eliminates maintenance costs associated with battery replacement. In addition, PWSTs can be bundled into multi-sensor modules.

A variety of sensors are used on distribution grids, and a key aspect of the sensing strategy is to determine the mix of sensors needed to meet any specific set of smart grid outcomes. Table 1 lists and describes some of the standard sensor types that fall within this definition.

**Table 1. Common grid sensor types.**

Sensor type	Description
<b>Faulted circuit indicator</b>	Provides a binary indication of the passage of a fault current (based on magnitude) past the sensing point.
<b>Line sensor</b>	Typically, samples voltage and/or current and provides various derived quantities, such as root-mean squared (RMS) volts and/or amps, real and reactive power, power factor, a limited number of harmonics (i.e., 3rd to 15th) of voltage or current, and total harmonic distortion (THD). Transducers may be electrical, magnetic, or optical.
<b>Phasor measurement unit</b>	Provides synchronized voltage and current synchrophasors (time synchronized by an accurate time signal, such as global positioning system or GPS), frequency, and rate of change of frequency. May also provide line power flows, breaker status, or other analog and/or digital values.
<b>Sag sensor</b>	Measures conductor sag (droop) in transmission lines. Transducers include cable tension meters and video camera/target approaches.
<b>Sway/aeolian vibration</b>	Measures wind-induced sway (conductor swing) and vibration in transmission lines.
<b>Snow/ice loading</b>	Measures snow/ice load on power lines during winter conditions.
<b>Dissolved gas</b>	Measures dissolved oil gas concentrations for up to nine gases in power transformers; may compute metrics of transformer health.
<b>Partial discharge</b>	Detects and counts arcing partial discharges in power transformers.

<b>Cable tan delta</b>	Measures phase shift on cable insulation.
<b>Bushing capacitance</b>	Measures capacitance on power transformer and breaker bushings.

**Table 1. Common grid sensor types (continued).**

Sensor type	Description
<b>Line temperature</b>	Measures temperature distributions on power lines—typically done with fiber optics.
<b>Residential meter</b>	In addition to electricity (kWh) usage (energy), may measure secondary voltage; may record data on voltage sags as measured on the secondary at the premise; a few also record real and reactive power and power quality measures, such as voltage THD.
<b>Commercial and Industrial (C&amp;I) meter</b>	In addition to electricity (kilowatt-hour or kWh) usage (energy), measures secondary voltage and current, computes real and reactive power, THD, and a variety of other configurable quantities. May capture power waveforms on a trigger basis for later retrieval.
<b>Feeder meter</b>	Provides meter-quality measurement of feeder primary quantities, including voltage, current, and real and reactive power.
<b>Digital fault recorder</b>	Captures and stores voltage and current waveforms upon the occurrence of an event (i.e., short-circuit fault) triggering.
<b>Winding hotspot monitor</b>	Monitors transformer temperatures (in the windings) and estimates hot spot temperature.
<b>Tap changer monitor</b>	Counts tap changer operations that increase/decrease downstream voltage. May also detect arcing and capture electrical and vibration signatures during tap changes.

Many modern distribution automation devices include a sensing capability as either an integral part of, or in addition to, their primary functions. Table 2 lists some examples of common grid devices that can also provide an integrated grid sensing functionality.

**Table 2. Common grid devices with sensing capability.**

Device	Sensing capability
<b>Switch controller</b>	Measures voltage; may record peak fault currents.
<b>Capacitor controller</b>	Measures voltage; may record peak fault currents; may compute real and reactive power.
<b>Recloser controller</b>	Measures voltage; may record peak fault currents.
<b>Voltage regulator</b>	Measures line voltage.
<b>Substation intelligent electronic devices (microprocessor relays)</b>	Can take transducer inputs for voltage and current directly; can compute many derived values, including real and reactive power, phasors, total harmonic distortion, power factor. Also acts as a gateway for other kinds of measurements, such as oil temperature and partial discharge data.

## 5. GMLC SENSING AND MEASUREMENT STRATEGY PROJECT

The GMLC Sensing and Measurement initiative is organized into three project areas that have strong ties and interfaces with many other actively funded GMLC projects (Figure 1).<sup>8</sup> The Advanced Sensors Project works to develop new sensors to meet the needs of the modern grid. The Data Analytics and Machine Learning Project seeks to identify gaps in data analytics for the modern grid and develop and apply machine learning as well as other analytics algorithms to turn sensor data into useful information to meet modern grid objectives. The Sensing and Measurement Strategy Project is developing an overall strategy for sensing and measurement, including identifying grid states, and determining sensors needed for applications, as well as determining communication requirements, and data management and analytics needs. This roadmap report is a product of the GMLC Sensing and Measurement Strategy Project.

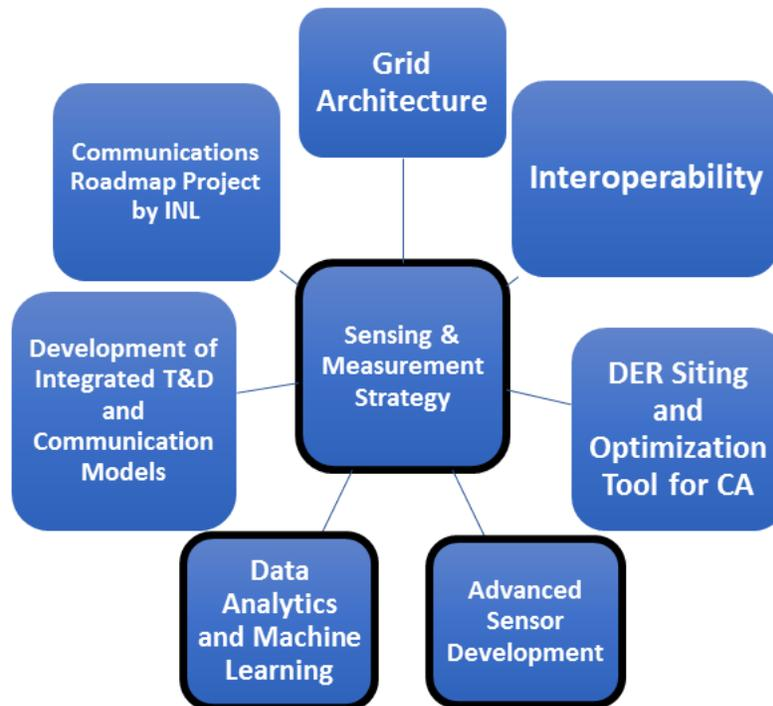

**Figure 1. Overall graphical representation of the GMLC sensing and measurement area. Core foundational projects are illustrated with bold lines and placed in the context of other related activities. Note: INL’s role is called out specifically since they were not part of the project team but participated in a voluntary fashion to provide input on the communications roadmap developed for DOE under another project.**

The GMLC Sensing and Measurement Strategy effort began in April 2016. It focuses on defining measurement parameters within the power system, devices for making these measurements, communication to efficiently transport these data to where they are needed, and data analytics to effectively manage the data and turn them into actionable information for operational and planning decisions. The following are the project objectives:

- Task 1: Create an extended grid state (EGS) reference model that extends beyond the traditional “T&D system” definition and framework, identifying the information needed to understand how to

---

<sup>8</sup> See the following links for more information: <https://gridmod.labworks.org/projects/>, <https://energy.gov/under-secretary-science-and-energy/doe-grid-modernization-laboratory-consortium-gmlc-awards>, <https://www.energy.gov/under-secretary-science-and-energy/grid-modernization-lab-consortium>

instrument the extended electric grid that includes renewables, responsive load, and other new technologies.

- Task 2: Develop a technology roadmap to drive development of sensing and measurement technologies needed to measure electric grid parameters, including quantitative metrics where applicable.
- Task 3: Develop a sensor placement optimization tool (SPOT) that supports the selection and allocation of sensors to achieve the best possible levels of observability subject to the reality of constraints on practical sensor placement and installation.
- Task 4: Conduct outreach to standards development organizations and technical groups to coordinate with industry to achieve its participation in the project, ensure industry acceptance, and identify standards (new and enhancements).
- Develop a test bed or beds for sensor qualification and certification. Such test beds would help developers of new sensor technology verify compatibility with the field environment and provide direct feedback from end users. Multiple use cases could be developed to test sensors, validate their integration into existing plant infrastructure, and more.

Figure 2 shows a graphical summary of the overall GMLC Sensing and Measurement Strategy project. It illustrates the EGS providing an overarching framework. It is then combined with a sensor technology roadmap as well as sensor placement and optimization tools to clarify the needs for advanced sensing and measurement technologies to support the GMI in the future.

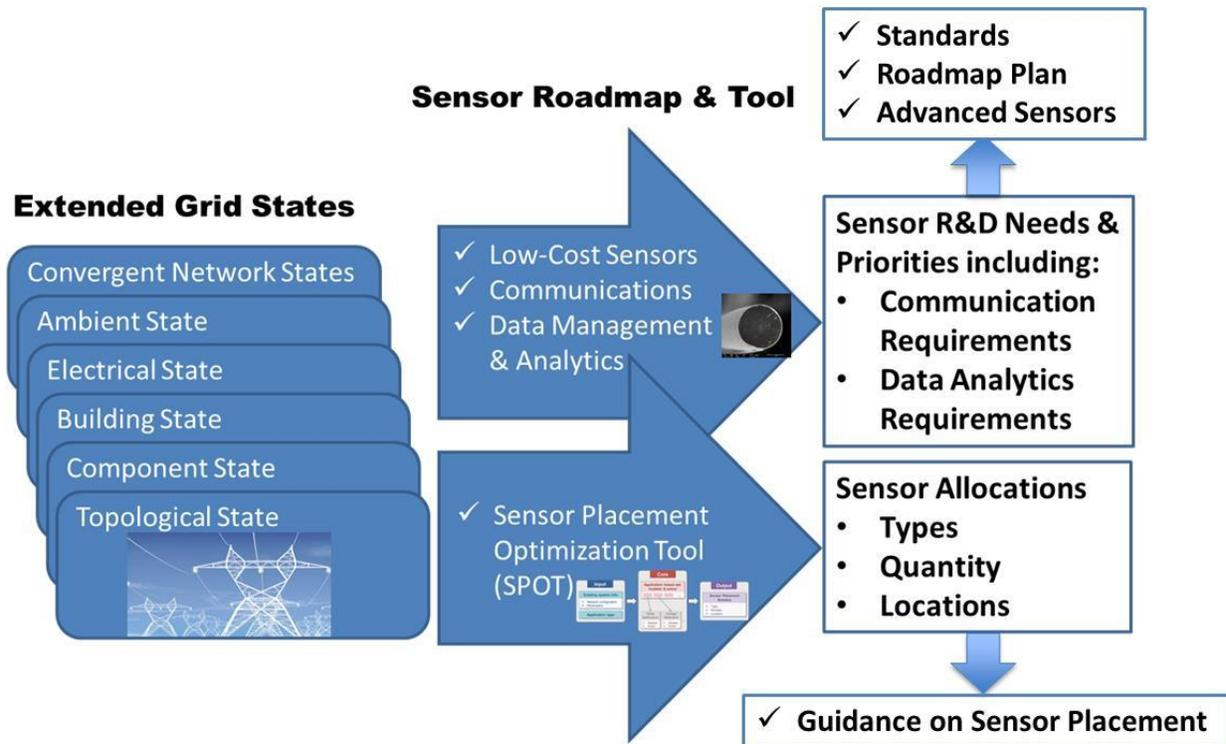

**Figure 2. A graphical summary of the overall GMLC Sensing and Measurement Strategy project.**

The Sensing and Measurement Strategy is being carried out by a large cross-laboratory team with active participation from ten of the DOE national laboratories:

- Oak Ridge National Laboratory (ORNL) is the lead for the project and tasks 3 and 4.
- National Energy Technology Laboratory (NETL) is the plus one (??) for the project and task 2 lead.
- Pacific Northwest National Laboratory (PNNL) is the lead for task 1.
- National Renewable Energy Laboratory (NREL)
- Sandia National Laboratories (SNL)
- Argonne National Laboratory (ANL)
- Lawrence Berkeley National Laboratory (LBNL)
- Lawrence Livermore National Laboratory (LLNL)
- Los Alamos National Laboratory (LANL)
- Idaho National Laboratory (INL)

Historically, grid monitoring has been used primarily for bulk electric power (generation and transmission) assets with little or no visibility at the distribution level, because monitoring devices have been costly to acquire and deploy and communications and analytical capabilities were limited and expensive to implement. But recent technology advances in materials science, electronics, photonics, communications, and advanced manufacturing have opened up new possibilities for the realization of cost-effective measurement and monitoring in every part of the power system. At the same time, advances in data storage and management, data analytics, and two-way control systems make it possible to use collected grid data to better control and manage the power system at all levels.

The technology advances making it possible to develop better sensing, measurement, communications and analytical capabilities include

- Additive manufacturing using functional materials in addition to structural materials to make novel sensors and embedded sensors inside or on items that are being monitored.
- PWST that enable ultra-low cost sensors.
- Network architectures that include fixed, man-portable, or mobile drone data collection. Using PWST does not place the intelligence at the edge but rather pulls it one step back at the interrogator. The intelligence is localized, but not all the way to the edge, significantly reducing up-front sensor cost and maintenance cost (no battery replacement).
- A wide suite of IT and communications (ITC) advances, including affordable high-speed communication networks, solid-state measurement and analysis on a chip, and high-density data storage and management capabilities.
- The convergence of measurement and control functionality into multi-function, multi-purpose measurement and control devices.
- Decentralization of analytics and controls out to the grid edge (closer to customer end-use locations and distributed generation injections), rather than sending all of the data back to a central hub for analysis. This enables more timely decision-making and action and multi-directional communications and controls.

- Big data analytics to recognize event signature patterns in very large data sets, diagnose power system problems and determine solutions from these data, improve asset management, and identify real-time operational threats and solutions gained from insights extracted from these data.
- The widespread use of technical standards and interoperability to enhance the interchangeability, coordination, availability, performance quality, and capabilities and lower the costs of sensing and measurement devices.
- Leveraging the use of ITC and analytics in many other industries and sectors to solve problems like those of the electric power sector. The electric power sector can look for solutions to analogous problems developed by the military (e.g., field force management and operational sector threat awareness), manufacturing (e.g., quality control monitoring in aircraft and semiconductor manufacturing), businesses (e.g., integration of diverse data for trending using machine learning and big data analytics), banking and finance (e.g., high-reliability communication and data quality and security management), and health care (e.g., use of surrogate, noninvasive, easy-to-monitor techniques such as acoustics and vibration to monitor hard-to-measure variables).

The Sensing and Measurement Strategy project team has considered these advances and others. The Technology Roadmap provides a suggested set of initiatives and research thrusts for a coherent, integrated, coordinated government and industry strategy for technology development and deployment in support of GMI goals. This document represents the current version of the *Sensing and Measurement Technology Roadmap* for the Sensing and Measurements Technical Area of the GMI. The Technology Roadmap is a living document that should be updated regularly by roadmap stakeholders.

## 6. SENSOR AND MEASUREMENT TECHNOLOGY ROADMAP PROCESS

This Technology Roadmap development effort seeks to accomplish the following objectives in support of DOE's GMI<sup>9</sup>:

1. Identify a clear understanding of the current state of the art in sensing and measurement devices, communications, and data management/analytics as it relates to the electric power system, spanning electricity generation, transmission, distribution, and ultimately end users.
2. Perform a gap analysis of sensing and measurement technology needs compared with the current state of the art.
3. Articulate the needed visibility to enable a modernized electricity grid infrastructure as outlined in the GMI Multi-Year Program Plan (MYPP).<sup>10</sup>
4. Develop a prioritized technology roadmap with recommendations for R&D in sensing and measurement.
5. Establish new, urgent, and targeted federal funding to support initiatives that accomplish the ultimate GMI objectives.

The GMLC Technology Roadmap has been developed as a collaboration across the DOE national laboratory system in close partnership with key partners and stakeholders from industry, academia, and other relevant government organizations. An abbreviated list of major participating stakeholder partners can be found in Figure 3. A more complete and detailed list of participating organizations and individuals is provided in Appendix D.

---

<sup>9</sup> <http://energy.gov/under-secretary-science-and-energy/grid-modernization-initiative>

<sup>10</sup> <http://energy.gov/downloads/grid-modernization-multi-year-program-plan-mypp>

- ▶ Utilities
  - Bonneville Power Administration
  - ComEd
  - Dominion Power
  - Duke Energy
  - Electric Power Board of Chattanooga
  - Entergy
  - ISO New England
  - NYISO
  - PEAK
  - PG&E
  - PJM
  - SMUD
  
- ▶ NASPI Task Teams
  - Distribution
  - Performance, Requirements, Standards & Verification
  
- ▶ Universities
  - Colorado State University
  - Florida State University
  - Michigan Tech
  - University of Albany-Sunny
  - University of CA- Berkeley
  - University of CA-Riverside
  - University of CA-San Diego
  - University of Oregon
  - University of TN-Knoxville
  - Virginia Tech
  
- ▶ Utilities (cont.)
  - Southern California Edison
  - Southern Co.
  - Tennessee Valley Authority
  
- ▶ Gov't Organizations
  - Army Research Laboratory
  - NCAR
  - NOAA
  - Joint Research Centre, Italy
  
- ▶ Industry Organizations
  - Electric Power Research Institute
  - GEIRINA
  - IEEE
  
- ▶ Vendors
  - Bosch
  - Brixon
  - Eaton
  - Eppley lab
  - Ground Work Renewables
  - Irradiance
  - ISO-CAL North America
  - Kipp & Zonen USA Inc.
  - Ping Thing
  - Opal-RT
  - OSIsoft
  - Schneider Electric
  - Wi-Sun Alliance
  - Yokogawa Electric Company

**Figure 3. Summary of various stakeholders involved in the Sensing and Measurement Strategy.**

The Technology Roadmap effort has been carried out as an iterative process: (1) summarize the current state of the art, (2) outline existing gaps, and(3) identify areas of potential need and opportunity for federal investment to make a significant impact.

The first phase of the roadmap process began with the development of an extended literature review by the national laboratory team that was subsequently updated in later stages of the project.<sup>11</sup> The result of this effort was a Technology Review and Assessment document that contains information on previous roadmaps, technical literature, program documents, and other resources used for the roadmapping effort. A first draft of the Technology Roadmap without detailed gap analysis or prioritization was presented to stakeholders in a public industry meeting held at ComEd in February 2017 to garner initial stakeholder feedback to inform the path forward. A revised draft of the Technology Roadmap slides was provided to DOE program managers for review and input in April of 2017.

The second phase of the process began in August 2017 with the goals of (1) improving the integration of the EGS definition with the Technology Roadmap; (2) engaging with stakeholders to refine the proposed research thrusts and perform a detailed gap analysis, including the development of quantitative metrics; and (3) developing a set of specific, actionable recommendations for federal initiatives that could advance the GMI objectives. The Sensing and Measurement Strategy project team established several working groups to coordinate and accomplish each of these primary objectives (see further details in Appendix C). These working groups consisted of national laboratory personnel and industry members. Each of these working groups operated independently, with oversight and coordination by the Sensing and Measurement Strategy project principal investigator and roadmapping task lead. More details of the roadmapping process, including the list of working group leads and summary reports from each working group, can be found in Appendix C.

The Technology Roadmap offers recommendations to achieve a coherent, integrated approach toward the development and deployment of new sensing and measurement technologies in support of GMI goals and objectives. A number of strategic focus areas and research thrusts have been identified, spanning the areas of (1) advanced sensing devices, (2) network communications, and (3) data management and analytics solutions that can meet the observability needs<sup>12</sup> of the current and future power system.<sup>13</sup> A set of high-value use cases is also presented, which can demonstrate tangible value and beneficial impact for the broad range of new sensing and measurement technologies being developed and deployed. A set of crosscutting sensing and measurement support efforts are also identified and recommended to accelerate the deployment, implementation, and impact of advanced sensing and measurement technologies within the modern power system.

The Technology Roadmap also reflects a new architectural definition for the modern grid, the EGS.<sup>14</sup> The EGS offers a common framework and description for the modern power system beyond just the cables,

---

<sup>11</sup> Review and Assessment of Sensing and Measurement Technology for Electric Grids, Devices Including Communications and Data Analytics Requirements, ORNL/SPR-2018/956, December 2018, prepared by the GMLC Sensing & Measurement Strategy Project (PI: D. Tom Rizy, Task Lead: Paul Ohodnicki) and posted on the GMLC website at <https://gridmod.labworks.org/resources>.

<sup>12</sup> The GMI work recognizes that the power system is dynamic and requires “temporal, geospatial and topological awareness of all grid variables and assets.” (Extended Grid State Definition Report, prepared by the GMLC Sensing & Measurement Strategy Project, PI: D. Tom Rizy, Task Lead: Jeff Taft, Version 3.2 current draft, to be published as a PNNL and GMLC Report.). Such observability enables “visibility,” estimation and forecasting of the power system, and therefore better situational awareness of current conditions and contingencies.

<sup>13</sup> The term “power system” refers to the entire scope of the electricity delivery system: generation, T&D, customer end uses and customer-owned electric production and storage devices, and all of the control and decision-making actors and activities along that thread (including energy management systems, automated systems, price- and market-responsive actions, and demand-response programs). The term “grid” is used to refer to only those elements that are located on the supply side of the meter, including generation, transmission, and distribution elements and communication networks.

<sup>14</sup> Extended Grid State Definition Report, prepared by the GMLC Sensing & Measurement Strategy Project, PI: D. Tom Rizy, Task Lead: Jeff Taft, Version 3.2 current draft, to be published as a PNNL and GMLC Report.

conductors, and other electrical assets that make up the electrical transmission and delivery system. The EGS includes the connected topologies and interactions for the following:

- Grid operations and control hierarchy and topologies
- All the grid's assets and components
- Communications and analytical systems
- Electrical conditions such as consumption, generation, fuel mix, electricity uses, and system performance, including specific electrical measurements
- Energy markets
- Ambient state external conditions that affect the power system, including weather and external operational constraints such as environmental emissions rules, North American Electricity Reliability Corporation (NERC) reliability standards, and a variety of dispatch and market rules

The latest version of the EGS definition<sup>15</sup> provides more detailed information and references. The graphical representation of the EGS is provided in Figure 4. This illustration is used to visualize intersections between the EGS and the high-value use cases identified in subsequent sections.

Through the team's efforts, focus areas have been identified for organization of the proposed Roadmap R&D efforts. Because of the complex, interconnected nature of the EGS and the modern electric power system, there is necessarily some degree of overlap among these focus areas. However, the focus area framework helps the Technology Roadmap team organize and present roadmap findings and recommendations while linking specific proposed research thrusts to broader emergent needs.

These focus areas are

- Crosscutting research that is needed to support the success of the sensing and measurement strategy
- Sensing and measurement devices
- Harsh environment sensors for flexible generation
- Grid asset health performance monitoring
- Phasor measurement units (PMUs) for grid state and power flow
- Novel electrical parameter transducers
- End-use/building monitoring
- Sensors for weather monitoring and forecasting
- Communication
  - Distributed communication architectures
  - Communications and networking technologies
- Data, analytics, and modeling
- Big data management for accessibility and visibility
- Analytics support and integration
- Advanced data analytics techniques, and applications
- Weather data for grid modernization

---

<sup>15</sup> Extended Grid State Definition Document, prepared by the GMLC Sensing & Measurement Strategy Project, PI: D. Tom Rizy, Task Lead: Jeff Taft, Version 3.2 current draft, to be published as a PNNL and GMLC Report.

The Sensing and Measurement Strategy's Technology Roadmap should evolve as additional information becomes available.

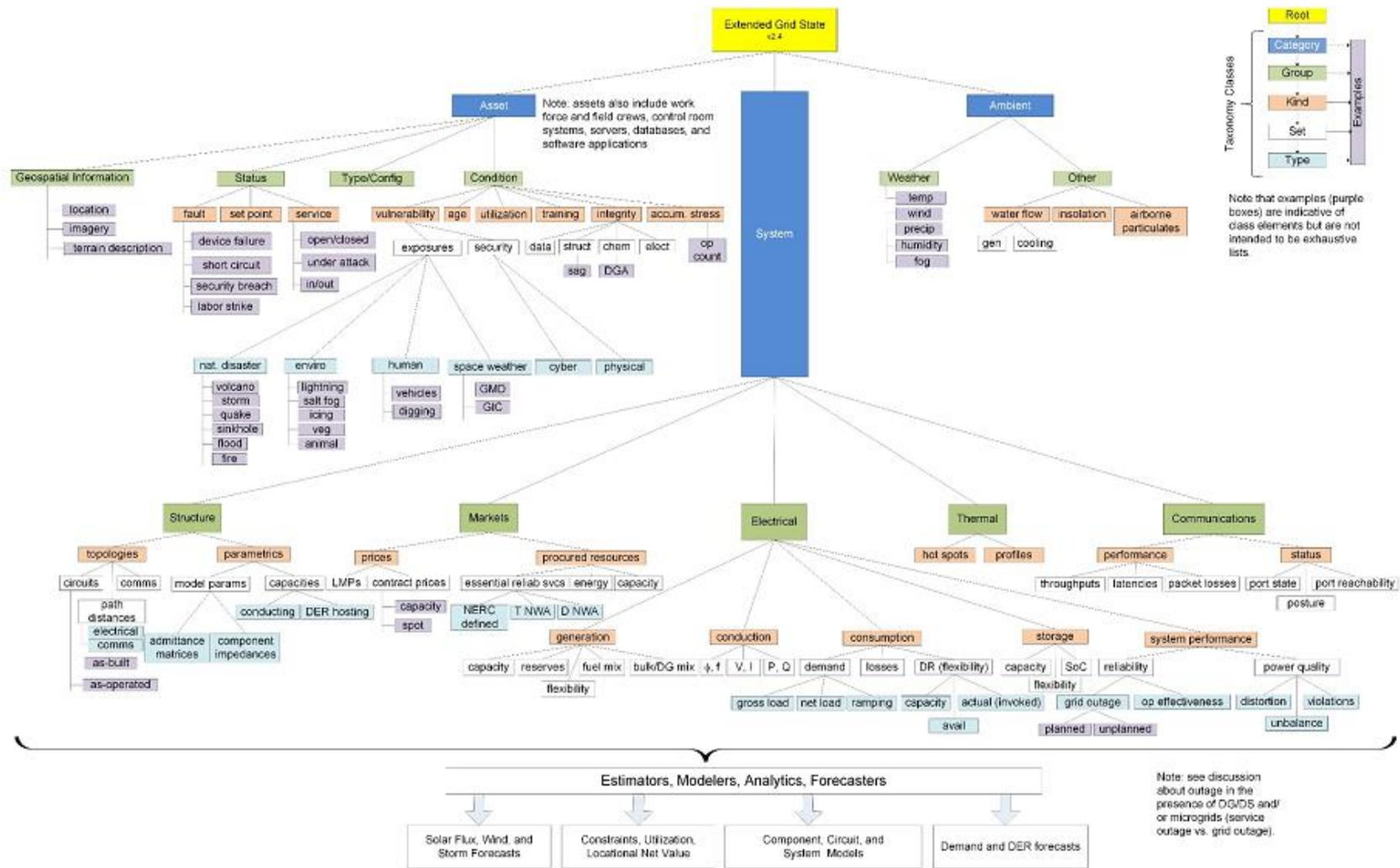

Figure 4. The taxonomy of the extended grid state<sup>16</sup>.

<sup>16</sup> Extended Grid State Definition Document, prepared by the GMLC Sensing & Measurement Strategy Project, PI: D. Tom Rizy, Task Lead: Jeff Taft, Version 3.2 current draft, to be published as a PNNL and GMLC Report.

## 7. TECHNOLOGY REVIEW AND ASSESSMENT DOCUMENT FINDINGS

The summary of findings in this section represents a high-level overview of what was learned from the development of a technology review in support of the phase of objective 1 outlined above in Section 6 in terms of the review of the state of the art of sensors.<sup>17</sup>

The discussion of sensing and measurement devices in the Technology Review and Assessment Report<sup>18</sup> was segmented into distinct application domains related to needs for the electric power system of the future:

- Conventional generation sensing for more flexible operation
- Renewable generation sensing and weather monitoring
- T&D power flow and grid state monitoring
- Asset monitoring and fault diagnosis
- End use/buildings monitoring for more responsive loads

There is necessarily some overlap between these domains, and they are expected to become even less distinct as the power system evolves to become more integrated and diverse. Nevertheless, sensing and measurement approaches and technologies needed to address these application areas are sufficiently distinct to organize focused efforts. The EGS definition has been developed under a parallel project activity.<sup>19</sup>

Useful insights about the current technology status within the application areas identified in the Technology Review and Assessment Report and emerging needs in sensing and measurement devices are summarized in the remainder of this section. They have been categorized into four areas in terms of crosscutting needs, sensing & measurement applications, communication requirements, and data management & analytics needs.

### **Emergent themes that crosscut the application areas**

1. Needs exist for advanced instrumentation at centralized generation and transmission levels.
2. There is a lack of visibility within the distribution system.
3. The per device” value of a sensor deployed on the distribution system or at the end-user level is dramatically lower than the value of comparable transmission system sensor.
4. Enhancing visibility in the distribution system and at the end uses requires advances in low-cost/value added sensors and in multifunction or multi-parameter sensors.
5. There are obvious needs for clearer definitions and standardization of requirements.

---

<sup>17</sup> Review and Assessment of Sensing and Measurement Technology for Electric Grids, Devices Including Communications and Data Analytics Requirements, ORNL/SPR-2018/956, December 2018, prepared by the GMLC Sensing & Measurement Strategy Project (PI: D. Tom Rizy, Task Lead: Paul Ohodnicki) and posted on the GMLC website at <https://gridmod.labworks.org/resources>.

<sup>18</sup> Review and Assessment of Sensing and Measurement Technology for Electric Grids, Devices Including Communications and Data Analytics Requirements, ORNL/SPR-2018/956, December 2018, prepared by the GMLC Sensing & Measurement Strategy Project (PI: D. Tom Rizy, Task Lead: Paul Ohodnicki) and posted on the GMLC website at <https://gridmod.labworks.org/resources>.

<sup>19</sup> Task 1 of Project 1.2.5 GMLC Sensing and Measurement Strategy Project.

6. Testing procedures for emerging sensor and measurement technologies are lacking. Tests of interest include:
  - a. Interoperability
  - b. Cyber-physical security
  - c. Resilience of new technologies
7. Standards and testing procedures are important aspects of the development and deployment of new sensing and measurement devices.
8. Valuation or value added is among the most important concerns and needs of utilities in making decisions regarding a sensor deployment project. However, it is an intricate problem consisting of many elements, including:
  - a. Cost/benefit analysis not only of the cost of devices but also of installation
  - b. Approval
  - c. Reliability impact and reliability/life cycle of the equipment
  - d. Regulatory risk assessment

There may be other considerations, such as the need for well-designed and validated evaluation tools/methods that will encourage the adoption and deployment of new sensor and measurement technologies, especially the emerging ones.

#### **Key insights derived for the various sensing & measurement application domains**

1. Harsh-environment instrumentation relevant for conventional thermal-based generators (e.g., fossil, nuclear) could enable more flexible operation and minimize long-term impacts of cycling and ramping on plant longevity and efficiency. Capabilities of existing automatic generation controllers (AGC) and associated sensing and measurement devices should be evaluated in terms of the potential for new technology innovations.
2. Weather monitoring technologies and instrumentation exist at high technology readiness levels, and emerging technologies often involve adaptation of technologies developed for other fields, such as unmanned aerial vehicles, lidar-based techniques, and satellite-based remote sensing. Additional needs include (1) developing low-cost sensing options for scalable deployment of weather sensors and enhanced grid-edge visibility; (2) integrating, calibrating, customizing emerging innovative technologies for grid operational purposes; (3) developing high-quality and portable calibration technologies; (4) achieving optimal deployment and usage of disparate weather-sensing resources for modeling complex weather phenomena for challenging terrains and severe weather events and for forecasting renewable generation at higher temporal and spatial resolutions (i.e., not just average forecasts, but capturing the uncertainties accurately in terms of probabilistic forecasts); and (5) effectively integrating them into energy management systems and distribution management systems for enhanced situational awareness and achieving a high level of system performances (i.e., lean reserves).
3. PMUs are a key technology for power flow and grid state monitoring; and opportunities exist for improvements in reliability, speed, accuracy, overall cost, especially for applications at the distribution level. Emerging electromagnetic phenomena-based current and voltage transducers show significant opportunity for new innovations but require reductions in cost.
4. Asset monitoring of electrical grid assets can be classified into both “functional performance” and “health monitoring.” The former requires predominantly electrical parameter sensors and the latter requiring sensors for a broad range of parameters, such as temperature, chemistry, and strain. Sensor instrumentation exists for established grid components, but high costs currently limit deployment to

the most critical assets. New sensing technologies are required for emerging grid components, such as power electronic-based solid-state transformers.

5. Trends of increased generation at residential and commercial scale, as well as projections for widespread electric vehicle deployment require increased visibility both in the distribution system and near or at the loads to enable demand response and transactive energy strategies. Low-cost sensor technologies for monitoring power flow as well as parameters characteristic of the current and forecasted load will be of increasing importance.

### **Conclusions related to communication needs**

1. A paradigm shift is occurring toward broader implementation of distributed, rather than centralized, architectures characterized by communication and intelligence at lower levels closer to the sensing and measurement devices.
2. Reduced latencies and robust peer-to-peer communication and communication between various nodes (or measurement points out on the power system) and the control center are of increasing importance.
3. Communication architectures with the following attributes are highly desirable:
  - a. Scalability to allow for managing many diverse sensing and measurement networks of varying sizes.
  - b. Flexibility to incorporate new types of data and applications.
  - c. Efficiency in leveraging unique features of different communication technologies.
  - d. Reduced latency with more distributed data processing and control.
  - e. Reduced vulnerability to cyberattacks.

### **Conclusions related to data management and analytics needs**

1. The desire for dramatically increased visibility across the electricity grid infrastructure will intensify the demand for the deployment of sensing and measurement devices, and its associated data management needs, to unprecedented levels.
2. A shift toward distributed data analytics methodologies rather than centralized approaches is a potential key piece of the required technical solution.
3. For the existing sensing and measurement infrastructure, a great amount of value has yet to be extracted through advanced data management and analytics approaches. This is especially the case at the distribution level, which has traditionally been limited to substation monitoring and control with very little to none on the distribution feeders.

The findings reported in this section have served as key inputs to the approach and organizational structure of the Roadmap. Through a formalized working group process and stakeholder engagements, the team has further developed and refined these early concepts and has also performed a detailed gap analysis, developed potential recommended research thrusts, and identified crosscutting initiatives. These findings have led to recommendations for federal efforts that can help to promote the goals of the GMI, in the sensing and measurement area. Key findings of this formal working group process are described in the following section.

## 8. WORKING GROUP GAP ANALYSIS RESULTS SUMMARY

Each DOE laboratory working group lead was asked to develop a team consisting of members from the DOE laboratory system, industry, and other relevant organizations as required to accomplish a defined objective related to advancing the Roadmap effort. The approach, results, findings, and recommendations from each working group are presented as working group summary reports in Appendix D. This section summarizes the primary results and recommendations of the formal working group process at an elevated level, as described in the introduction section. Also, the results are integrated into an overall capability analysis.

A “capability gap” is defined here as a deficiency such as performance (e.g. precision, repeatability, reliability) in existing sensing and measurement technologies. Alternatively, the capability gap can refer to a gap in the surrounding institutional frameworks, regulations, or standards needed to support the objectives of the DOE GMI for the sensing and measurement area. All identified gaps and suggested approaches to address these gaps—including the pursuit of new research thrusts, establishment of targeted crosscutting initiatives, and other recommendations—are presented from these two perspectives. Because the Roadmap effort was also established in parallel with the announcement of a major investment in new initiatives across DOE to support the mission of the GMI, the Roadmap is written so that existence of ongoing activities to address identified gaps within the GMI/GMLC portfolio does not preclude them from being included in the document. The team has identified and mapped linkages with existing activities and efforts in the working group summary reports presented in Appendix D.

Tables 3–5 in this section and Table 6 in Section 9 are summary tables outlining key capability gaps and a summary of overall team findings organized as follows:

1. Uses and sensing technology targets
2. Communications and networks
3. Data management and analytics including grid modeling
4. Crosscutting issues

### 8.1 USES AND SENSING TECHNOLOGY TARGETS

Many capability gaps can be clearly linked to (1) specific parameters that require improved visibility through advanced sensor device technology development, (2) needs for development of enabling technologies to support the successful realization of advanced sensor devices, and (3) characteristics of advanced sensor device technologies. These gaps are grouped in Table 3 within the subcategories Issues to monitor, Advanced materials and techniques, and Needed advancements.

#### 8.1.1 Issues to Monitor

Several specific parameters were identified as being relevant for the broad range of grid sensing applications. In the case of asset health monitoring, a number of emergent opportunities were identified including (1) proxy sensors, such as vibration or acoustic sensors external to a grid asset that can indicate faults or failures that are otherwise difficult to measure directly, (2) tilt sensors to monitor utility pole and line orientations relative to their vertical and horizontal directions, (3) internal parameter measurements within electrical grid and thermal generator assets, such as temperature and chemistry, and (4) electrical parameter measurements, including high frequency/bandwidth and frequency-selective responses. Electrical parameters and proxy sensors were identified as particularly suitable for detection of low-frequency but high-consequence faults or failures due to natural or human-caused threats to the modern electric power system. Electrical parameter sensors focused on characteristic frequency bands may become increasingly important for application within emerging electric power system technologies, such

as solid-state transformers and energy storage. Internal temperature measurements and internal chemistry measurements, in contrast, can be used to identify the onset of failures due to natural aging or higher frequency but less acute disturbances. Tilt sensors for utility poles and lines can enable more rapid response times in cases where a power system infrastructure failure has occurred. They can also clearly indicate locations where inspections should be conducted to proactively avoid the potential for costly and disruptive system disturbances.

### **8.1.2 Advanced Materials and Techniques**

In support of the development of new sensing platforms with ideal characteristics for modern power grid applications, many enabling technologies and developments have been identified that should be pursued in conjunction with the development of novel sensor devices. More specifically, there is a need for advanced sensing material R&D to support the need for sensor transducing elements with optimal characteristics for a particular application requirement. Functional sensing materials can be integrated within various sensing platforms. Engineered materials can greatly simplify the cost and complexity of a sensor device. There is also a need for advanced packaging and sensor device approaches and materials that are compatible with both the electric power system and thermal generator application environments. New low-cost, scalable manufacturing approaches have potential for significant impact on overall sensor cost. Advanced methods including additive manufacturing, integrated circuit processing, advanced photonic-based manufacturing methods, and roll-to-roll manufacturing techniques should be considered.

### **8.1.3 Needed Advancements**

Several key attributes are required for emerging sensor technologies to have a significant impact on the successful realization of the GMI objectives. One major consideration is the balance of trade-offs between (1) the cost of a device and its deployment and (2) the value of the sensing technology to the owner of the asset in question. The overall cost of the sensor deployment will ultimately dictate whether a particular technology can be deployed ubiquitously or must be reserved for monitoring only the most critical assets within the electric power system. Note also that in many cases, there is a disconnect between the value of a new sensing technology in terms of its contributions to overall electric power system stability, and the local value that the owner of the asset in question can extract. Many sensing and measurement technologies already exist and are widely deployed across the electric power system. However, there is a disconnect between organizations responsible for covering the full costs of deployment, and the full system-level value of new sensing and measurement technology ubiquitously deployed across the system. Therefore, it is not anticipated that the private sector alone will lower the costs of new sensing technologies to the desired price point for accomplishing GMI objectives. Thus, significant capability gaps exist with regard to (1) dramatic cost reductions for existing sensor technology platforms with similar performance and (2) development of ultra-low-cost sensing technologies with reduced but acceptable levels of technical performance. In addition to major cost reductions, there are also significant opportunities to focus investments on a limited number of flexible sensing platform technologies that can be tailored for a broad range of electric power system monitoring applications through (1) multi-parameter functionality, (2) passive or “power-free” operation at the sensing node, and (3) optimized spatial deployment strategies for monitoring a specific parameter of interest. Examples include linear position sensors for power line sag monitoring, areal imaging for larger grid assets, substations with a high density of grid assets, and point sensors for widely distributed assets.

Table 3 provides more details regarding these gaps and potential approaches to addressing them.

**Table 3. Gap analysis summary for uses of sensing and technology targets.**

Gaps identified by working groups	Working groups	Potential approaches to address the gaps
Issues to monitor		
<p><b>Nontraditional proxy sensors</b></p> <p>Nontraditional but readily queried proxy sensors can be deployed for early detection of fault conditions</p>	<p><b>Asset health</b></p>	<p>Develop low-cost proxy sensors that can be ubiquitously applied to grid assets, including acoustic and ultrasonic vibration monitoring</p>
<p><b>Utility pole and line orientation at distribution level</b></p> <p>Local monitoring of utility pole and line orientation, relative to true vertical and horizontal orientation, can enable prevention of failures and more rapid recovery and restoration times</p>	<p><b>Asset health</b></p>	<p>Develop low-cost tilt sensors for poles and lines that can be ubiquitously applied to grid assets</p>
<p><b>Advanced thermometry for internal grid asset monitoring</b></p> <p>Thermal signatures are a primary indicator of grid asset (e.g., transformer) health status leading to faults and failures. However, internal faults exhibit characteristic hot spots that can be difficult to detect</p>	<p><b>Asset health</b></p> <p><b>Novel transducers</b></p>	<p>Develop multipoint temperature sensor technologies and extremely low-cost single-point sensor technologies for improved asset monitoring</p>
<p><b>Internal chemistry monitoring for grid assets</b></p> <p>Dissolved gas analysis (DGA) plays a key role in asset health monitoring of transformers but it is cost-prohibitive to make frequent measurements. Thus, measurements are only done periodically. Real-time measurement systems are deployed at only the most critical assets</p>	<p><b>Asset health</b></p>	<p>Develop real-time online DGA technologies of varying performance for specific application ranges and at dramatically reduced costs. For example, leveraging emerging sensor technology platforms rather than accurate but costly direct spectroscopic monitoring techniques should be explored</p>
<p><b>Internal generator parameters for flexible operation</b></p> <p>Existing generation plant monitoring will become increasingly important because more flexible operation is needed to accommodate intermittent renewable deployments in a modern grid</p>	<p><b>Asset health</b></p> <p><b>Harsh environment</b></p>	<p>Address specific metrics identified around the needs of internal monitoring of centralized generators. A specific research thrust was identified for boiler water chemistry monitoring based on industry input</p>
<p><b>Rapid electrical parameter sensing for dynamic protection</b></p> <p>Electrical parameters provided by fast-acting and broadband sensors can provide most rapid signatures of low-probability, high-consequence events, such as human or natural threats (e.g., geomagnetic disturbance, electromagnetic pulse). They can also play a key role in dynamic system protection and offer a better understanding of dynamic operating states</p>	<p><b>Asset health</b></p> <p><b>Novel transducers</b></p>	<p>Develop rapid high-bandwidth and low-latency electrical parameter sensors with sufficiently low cost for ubiquitous deployment</p> <p>Develop a new set of transducers capable of providing information about rates of changes (dynamic) of voltage, current, and frequency</p>

**Table 3. Gap analysis summary for uses of sensing and technology targets (continued).**

Gaps identified by working groups	Working groups	Potential approaches to address the gaps
<p><b>Electrical parameter sensors for asset health /performance</b></p> <p>Electrical parameter sensors can be used to gain information about the asset health and performance of existing grid devices. Such sensors are expected to be even more important in the future for emerging technologies such as next-generation (solid-state) transformers</p> <p>Abnormal behavior (e.g., failures, faults, or severe degradation of performance of an asset) manifests itself in a deviation from nominal operating frequency or presence of abnormal frequencies (such as new harmonics or completely new frequency characteristics). Detecting such frequencies is key to the early identification of faults and failures in assets across the modern power system</p>	<p><b>Novel transducers</b></p>	<p>Develop new sensors capable of providing accurate information on frequency signature and total harmonic distortion (THD) as well as voltage and current at a price point that is cost effective for multiple asset monitoring.</p> <p>Emphasize low-cost solutions that can deploy directly at/on the asset to be monitored to complement approaches that seek to leverage analytics combined with non-local PMU-based monitoring solutions</p>
<p><b>End use-level sensors for leveraging IoT devices</b></p> <p>Sensors creating actionable information from new smart internet-capable appliances and devices installed behind the meter (customer) location are not ubiquitous</p>	<p><b>Novel transducers</b></p>	<p>Develop sensor solutions that monitor the performance of a variety of devices at the customer level and broadcast this information to the utility. Examples include “smart outlets” that can collect power and power quality information, and smart meters that provide revenue information, power, and power quality information for all devices at the customer’s interconnection</p>
<p><b>Enhanced visibility of weather-dependent resources</b></p> <p>With increasing penetrations of wind- and solar-dependent energy sources, both at the transmission and distribution (behind the meter) levels, utilities and energy management systems have increasing needs for higher temporal and spatial resolution visibility of device statuses and their expected power generation. This will provide system operators with situational awareness for making timely decisions. It will also enable reliable integration of variable renewables and efficient management of their power ramps for grid reliability and resilience</p>	<p><b>Weather</b></p>	<p>Develop mesonets, weather stations, and sky camera devices that provide high resolution (&lt;1 km spatial and seconds-minutes time intervals), real-time, on-demand weather information</p> <p>Develop visualization technologies that provide near-real-time situational awareness of renewable devices as well as associated grid states</p> <p>Integrate satellite sensing data with ground-mounted or drone mobile sensors to achieve higher spatial and temporal resolution</p>

**Table 3. Gap analysis summary for uses of sensing and technology targets (continued).**

Gaps identified by working groups	Working groups	Potential approaches to address the gaps
<b>Advanced materials and techniques</b>		
<p><b>Enabling materials for sensing elements</b></p> <p>Advanced materials development plays a critical enabling role for new sensing elements in a variety of sensor devices</p>	<b>Harsh environment</b>	<p>Pursue foundational advanced sensing materials research and engineering to provide specific application requirements, which may include deployment within internal grid assets or within centralized thermal generators</p>
<p><b>Enabling materials for harsh environment sensors</b></p> <p>Robust packaging technologies are required to ensure reliable, durable performance and compatibility with electric power system applications</p>	<b>Harsh environment</b>	<p>Leverage existing solutions developed for applications in harsh environment sensing applications to the extent possible (e.g., aviation, oil and gas, automotive)</p> <p>Pursue foundational research in new packaging and device materials capable of performing within specific application requirements. May include deployment internal to grid assets or centralized thermal generators achieved with advanced materials science and engineering techniques</p>
<p><b>Advanced manufacturing of low-cost sensor platforms</b></p> <p>Advanced manufacturing techniques can be leveraged to fabricate low-cost, scalable sensor devices required to achieve appropriate balance of cost and performance targets</p>	<b>Harsh environment</b>	<p>Develop novel manufacturing and fabrication processes that enable advanced concepts, such as embedded sensing and multi-functional sensing and measurement devices</p>
<b>Needed advancements</b>		
<p><b>Dramatic cost reductions for existing sensor technologies</b></p> <p>Many sensor technologies exist, but their deployment and ultimately their impact are limited by total deployed cost</p>	<b>End use</b>	<p>Develop radically lower-cost high-resolution current/voltage sensors; PMU technology; dynamic line ratings; and asset health monitoring sensors, such as DGA and others.</p>
<p><b>Scalable weather monitoring sensors</b></p> <p>Technologies that are customer-integrated, low-cost, and scalable are required, especially for grid modernization futures that will include increasing levels of behind-the-meter photovoltaic and DER implementation</p>	<b>Weather</b>	<p>Integrate innovative technologies, including those applied in other fields such as agriculture sensing for variable renewable grid integration. These technologies include arable pulsepod, reference cells, security cameras for sky imaging, and lidar technologies. Extensive research is needed to enable their integration, calibration, spectral properties characterization, and validation for future grid applications</p>

**Table 3. Gap analysis summary for uses of sensing and technology targets (continued).**

Gaps identified by working groups	Working groups	Potential approaches to address the gaps
<p><b>New low-cost, multifunctional and flexible sensor platforms</b></p> <p>There is a lack of ubiquitous multifunctional and flexible sensor platform technologies with attributes specifically compatible with electric power system monitoring applications. These technologies can offer advantages in terms of compatibility with standardization of data and communication protocols and efficient leveraging of R&amp;D investment</p>	<p><b>End use</b></p>	<p>Develop multicomponent integrated, low-cost sensor platform technologies for a range of applications, including building efficiency and power system asset health monitoring. Platform technologies may include wireless, self-powered, self-calibrating sensors for large-scale deployment with capability for auto self-configuration and commissioning. Platforms may also include optical-based technologies that overcome the limitations of deploying electrical sensors in electric power systems and within electrical assets</p>
<p><b>Sensing platforms with optimal spatial characteristics</b></p> <p>Localized signatures of failures or faults are difficult to detect with individual sensors and must instead be solved through sensor networks</p>	<p><b>Harsh environment</b></p> <p><b>Asset health</b></p>	<p>Develop complementary techniques and platform technologies that enable multipoint measurements, areal imaging, or linear mapping of parameters of interest with optimal trade-offs in spatial resolution, cost, and performance</p>
<p><b>Passive or energy harvesting-based sensor technologies</b></p> <p>Energy harvesting or passive sensor technologies can enable ubiquitous deployment without the need for a separate power source or connection to the electric feeder. Also, it eliminates the need for maintenance of a battery source</p>	<p><b>Harsh environment</b></p>	<p>Develop novel approaches to satisfy sensor power requirements, including passive sensor technology platforms and reliable, robust low-cost energy harvesting techniques</p>
<p><b>Leverage Existing Ubiquitous Networks</b></p> <p>Data from existing mobile/cellular phones could be a source of data.</p>	<p><b>Crosscutting</b></p>	<p>Crowd sourced data may be collected via phone apps or other voluntary data collection approaches. Phones already track certain weather conditions.</p>

## 8.2 COMMUNICATION AND NETWORKS

Several capability gaps could be clearly linked to (1) optimized spectrum utilization and ease of integration of new technology platforms into various communications networks, (2) overall architecture characteristics, and (3) standards and protocols for communication and networking technology. Therefore, these gaps are grouped in Table 4 within subcategories as Utilization and integration, Architecture, and Standards and protocols.

### 8.2.1 Utilization and Integration

One major capability gap involves the need for optimized spectrum utilization. There is a need to address challenges related to congestion and under-utilization within the communication infrastructure as more numerous and varied sensing and measurement devices are deployed throughout the electric power system. Opportunities to address this capability gap include hierarchical networks with distributed intelligence and distributed communications scheduling schemes. Another gap identified is that advanced communication protocols such as 5G cellular and OpenFMB are not yet fully integrated within utility communication network architectures. Regular engagement with utilities, standards, and regulations is

likely to be the primary method of addressing this capability gap. A need for a larger selection of IoT technologies capable of high (>99%) reliability and low (1 ms) latency was also identified to support the needs of the GMI. Addressing this gap may also require the development of sensor technologies with onboard data assimilation, analytics, and communication and with distributed intelligence to reduce the requirement for information flow and alleviate burdens on communication systems. Cybersecurity, particularly as it relates to data sharing, has also been identified as a significant capability gap: multiple users across a network can cause significant challenges regarding intertwined communications and the potential for breaches of data security and privacy. Among other potential solutions, a proposed approach to address this gap is to develop a strict, clear framework for cybersecurity and privacy implications and rules for the broad variety of data and data uses to assist in structuring further sensor, communications, and architecture development.

### **8.2.2 Architecture**

A clear capability gap was also identified for communication architectures that require compatibility with advanced security, authentication, and communication protocols, as well as flexibility, dynamism, and scalability. Potential approaches identified to address this gap include compiling both latency and throughput requirements for existing and key emerging sensor platforms for which R&D is currently being performed, and developing a compendium of IoT and Industrial IoT (IIoT) vendor and industrial group recommended architectures. Spectrum utilization, distributed intelligence and dynamic communication resource allocation are potential opportunities that can be achieved, for example, through the integration of smart connectivity managers within a network architecture.

### **8.2.3 Standards and Protocols**

Devices that are not interoperable can create interference and increase the costs and challenges of developing and implementing new sensor technologies into the electric power system. Therefore, a significant capability gap related to communication and networks is the need to improve interoperability as well as standards for new and existing device communication. Potential approaches to address this gap include (1) developing and applying improved techniques for predicting the interference and utilization impacts of devices that are not fully interoperable, (2) developing device solutions that are agnostic to communication technology, and (3) seeking solutions that can help ensure new devices are fully interoperable and compatible with existing standards.

**Table 4. Gap analysis summary for communication and networks.**

Gaps identified by working groups	Working groups	Potential approaches to address the gaps
<b>Utilization and integration</b>		
<p><b>Optimal spectrum utilization</b></p> <p>Optimal spectrum utilization to address challenges associated with congestion and under-utilization within the communications infrastructure, and to optimize scheduling of device communication</p>	<p><b>Distributed communication</b></p> <p><b>Communication technologies</b></p>	<p>Engage with a variety of industry organizations and government agencies to understand ongoing activities and challenges in the communication area for leveraging in the electric power area</p> <p>Improve spectrum sharing through techniques such as distributed scheduling schemes for device communication, which may include leveraging distributed intelligence as well</p>
<p><b>5G cellular integration for grid sensors</b></p> <p>5G cellular services are not fully integrated within utility communication network architectures</p>	<p><b>Distributed communication</b></p>	<p>Engage with utilities to determine plans for wireless sensors and advanced cyber-physical network topologies relevant for applicability to electric power systems</p>
<p><b>Cybersecurity and data sharing</b></p> <p>Multiple data users on a shared transport medium can create challenges in terms of intertwined communication performance and cybersecurity across the different layers of the network topologies</p>	<p><b>Distributed communication</b></p> <p><b>Communication technologies</b></p> <p><b>Weather</b></p>	<p>Reexamine best practice guides for control systems applicable to electric power systems and engage with relevant organizations and other agencies</p> <p>Attempt to quantify uncertainties and security risks associated with existing data sharing methods and investigate techniques for dynamic routing through “smart connectivity managers” to minimize them</p> <p>Develop a strict, clear framework for cybersecurity and privacy implications and rules for the broad variety of data and data uses to assist in the structuring of further sensor, communication, and architecture development</p>
<p><b>Ensuring low latency with high reliability</b></p> <p>Not many IoT technologies can support 1ms latency with &gt;99% reliability. These requirements must also be evaluated with respect to grid modernization use cases</p>	<p><b>Communication technologies</b></p> <p><b>Weather</b></p>	<p>Investigate both 5G- and IoT-related techniques to clarify latency and other performance gaps as they relate to secure electric power system communications</p> <p>Investigate distributed intelligence to reduce information flow requirements</p> <p>Develop sensors with onboard data assimilation, analytics, and communication for a low-latency distributed architecture that can facilitate local and speedy control decisions</p>

**Table 4. Gap analysis summary for communications and networks (continued).**

Gaps identified by working groups	Working groups	Potential approaches to address the gaps
<p><b>Lack of full leveraging of openFMB or other advanced communications protocols for grid sensors</b></p> <p>OpenFMB is not fully leveraged for electric power system/grid sensors, and the choice of networking technology is not necessarily obvious with many options available</p>	<p><b>Communication technologies</b></p> <p><b>Communication technologies</b></p>	<p>Set up a cluster of use sensor cases to determine requirements and whether a smart connectivity manager as a subset of an OpenFMB interface layer or other advanced communication protocols should be considered</p>
<b>Architecture</b>		
<p><b>Flexible, dynamic, scalable, and compatible architectures</b></p> <p>Current architectures are inadequate for advanced security and authentication protocols (e.g., OpenFMB, ICCP V2)</p> <p>A broad range of varying IoT/Industrial IoT devices, sensors, and systems exist and must be interfaced for deployment throughout utility networks (including residences). Further, with frequent updates of sensing resources (e.g., GOES-R satellites and their advancements), communication and data assimilation architectures must be robust to adapt and integrate with utilities</p>	<p><b>Distributed communication</b></p> <p><b>Communication technologies</b></p> <p><b>Weather</b></p>	<p>Identify throughput and latency requirements for emerging sensor platforms (as opposed to individual specific sensors)</p> <p>Develop compendium of IoT/Industrial IoT vendor and industrial group recommended architectures and explore a smart connectivity manager. Enable dynamic resource allocation and network control features in real time, as well as plug and play features at the device level. Incorporate distributed intelligence into the network and seek to achieve communication technology independent solutions</p>
<b>Standards and protocols</b>		
<p><b>Interoperability and standards for device communication</b></p> <p>Non-interoperable devices create interference and increase the costs and challenges of developing and implementing new device technologies</p>	<p><b>Communication technologies</b></p>	<p>Seek ways to increase or ensure device interoperability</p> <p>Develop improved techniques to predict interference and utilization impacts of non-interoperable devices (e.g., machine learning at device level)</p> <p>Find or develop device solutions agnostic to the communication technology</p>

### 8.3 DATA MANAGEMENT AND ANALYTICS INCLUDING GRID MODELING

#### 8.3.1 Data Management

A major capability gap related to the area of data management revolves around the standardization of data acquisition and the need to reduce the siloing of data types/formats within specific applications. There is a lack of established best practices and standards regarding managing, interfacing, and sharing large and separate data sets. One potential approach to be considered involves establishing a consortium, potentially

within the GMLC, specifically focused on the development and application of standards for data acquisition, distribution, sharing, and exchange that are subject to both cybersecurity and privacy considerations within the sensing and measurement domain. Additional capability gaps identified include a need to develop clear data requirements for accuracy, quality, and reliability and to develop or apply methods for real-time monitoring of data quality. Potential approaches to address these gaps include the development of clarified metrics to address the impact of data quality on various algorithms and analytics methods for use within the modern electric power system application domain. Relevant techniques, such as artificial intelligence and big data analytics that have been targeted specifically toward application within PMUs through the North American Synchrophasor Initiative (NASPI), may also be adapted and applied to the broader array of data types relevant for sensing and measurement under the GMI.

### 8.3.2 Data Analytics

A major capability gap in data analytics is related to the spatial aspects of sensing and measurement. Localized events that must be detected, monitored, or quantified via advanced analytics, using only a limited set of sensor nodes, are unlikely to be co-located at the source of the event in question. Hence, there is a need to develop and implement techniques such as geospatial analytical methods and incorporate disparate data sources from distinct locations and sensing platforms. Addressing data standardization capability gaps (discussed in Section 7) can help in integrating data across multiple types of sensor platforms and significantly improve the potential for developing and applying advanced analytical methods. For early or incipient fault detection and rapid detection of low-probability, high-consequence events, advanced analytical techniques can be developed and deployed in conjunction with ubiquitous electrical parameter measurements from a wide range of data sources. In many cases, advanced data analytical techniques can even be applied to the existing sensing and measurement network. Data analytics also can be applied to weather and other environmental sensor and measurement devices to meet a need for ways to accurately forecast DER generation.

**Table 5. Gap analysis summary for data management, modeling, and analytics.**

Gaps identified by working groups	Working groups	Potential approaches to address the gaps
<b>Data management</b>		
<p><b>Standardization of data acquisition in grid sensors</b></p> <p>A lack of consensus and standardization exists related to data and communication protocols because data formats and data collection are not interoperable. This is particularly a challenge for the deployment of sensors outside of the substation, because the integration with existing utility tools such as a data management system (DMS) or supervisory control and data acquisition (SCADA) can be a barrier. This is also true for weather sensing information that gets ingested by different utilities in different formats</p>	<p><b>Harsh environment</b></p> <p><b>Data management</b></p> <p><b>Novel transducers</b></p> <p><b>Weather</b></p>	<p>Establish best practice guidelines and testing measures for DMSs. Establish a GMLC consortium focused around development and use of data standards.</p>

**Table 5. Gap analysis summary for data management, modeling, and analytics (continued).**

Gaps identified by working groups	Working groups	Potential approaches to address the gaps
<p><b>Data availability, interfaces and utilization</b></p> <p>Sensing and measurement data are disparate and owned by many different organizations. Data are frequently siloed (e.g., in terms of formatting) within specific applications and not accessible by planning entities or a broad range of analytic tools that could make use of them</p>	<p><b>Data management</b></p> <p><b>Weather</b></p>	<p>Establish best data interchange practices along with tools and technologies for managing and interfacing large disparate data sets</p> <p>Establish standards and technologies for appropriately distributing, exchanging, and sharing the data subject to security and privacy considerations</p> <p>Establish a consortium that includes data owners, users and the communication community for cyber-secure sharing and dissemination of data for various use cases</p>
<p><b>Unclear data requirements (accuracy, quality, and reliability)</b></p> <p>There is a lack of clarity regarding data requirements for various grid applications and analytics approaches to accomplish system-level objectives</p>	<p><b>Weather</b></p>	<p>Develop hybrid (physics-based and data-driven) models that relate grid applications and parameters of interest (e.g., weather-dependent parameter forecasts, state estimates) to understand the impacts of different resources, varying reliability, data coverage, and sensing infrastructure costs on application performance—including convergent infrastructures (energy, fuel, gas, water and transportation)</p>
<p><b>Need for data quality monitoring in real time</b></p> <p>Data quality from new and existing sensors drives application performance and algorithm usefulness. It is critical to ensure the quality of application results and thus of data. Industry often considers this issue “solved” but it often returns as a critical matter after deployment</p>	<p><b>Data analytics</b></p> <p><b>Weather</b></p>	<p>Develop consistent metrics and methodology to evaluate the impact of data quality on a range of algorithms across the grid and analytics domains</p> <p>Develop techniques/technology to ensure data quality for commissioning and over the operational lifetime</p> <p>Explore application techniques previously developed under NASPI, including artificial intelligence and big data analytics for PMU data</p>
<b>Data analytics</b>		
<p><b>Lack of leveraging data across sensor platforms and data types</b></p> <p>Data-driven analysis is siloed by sensor and data type; thus the analysis does not leverage the full range of data available for maximal efficiency and lowest cost</p>	<p><b>Data analytics</b></p>	<p>Present use cases in a multisensor and data domain and develop demonstrations of multimodal, multivariate machine learning techniques for real time and predictive analysis of a wide range of grid conditions as presented in the use cases</p>

**Table 5. Gap analysis summary for data management, modeling, and analytics (continued).**

Gaps identified by working groups	Working groups	Potential approaches to address the gaps
<p><b>Analytics of electrical parameters using existing devices</b></p> <p>Electrical parameters provide the most rapid signatures of low-probability, high-consequence events, such as human or natural threats (e.g., geomagnetic disturbance, electromagnetic pulse)</p>	<p><b>Data analytics</b></p>	<p>Deploy analytics with existing and emerging electrical parameter measurements to extract new value from existing sensing and measurement devices while fully leveraging emerging technologies</p>
<p><b>Lack of forecasting models for DER generation</b></p> <p>Innovative forecasting models that not only forecast power from utility-scale renewable resources but also from behind-the-meter technologies are important. In many distribution feeders, not all of the nodes have advanced metering infrastructure, and utilities have little visibility of DERs that affect the net load at the substation feed</p>	<p><b>Weather</b></p>	<p>Use big data analytics in conjunction with numerical weather prediction to develop probabilistic forecast models to develop models for behind-the-meter DER resources.</p> <p>Use sky cameras and image processing to characterize cloud impacts on solar resources and forecasted power from renewable resources</p> <p>Validate satellite data based on ground-mounted sensors and improve the spatial and temporal resolutions of forecasting models</p>
<p><b>Challenges of fault location with distributed sensor networks</b></p> <p>Non-localized signatures of failures or faults are difficult to detect with individual sensors</p>	<p><b>Data analytics</b></p>	<p>Develop analytics that use disparate data sources for fault location and identification</p>
<p><b>Data-driven weather modeling</b></p>		
<p><b>Advanced forecasting models and their integration</b></p> <p>The continued growth in renewable energy, especially behind-the-meter, necessitates innovative forecasting models that have high spatial and temporal resolution and that not only forecast the mean power but also their ramps and associated uncertainties. The impact of variable renewables on feeder or substation net load forecasts must be determined as well</p>	<p><b>Weather</b></p> <p><b>Data analytics</b></p>	<p>Develop advanced forecasting models for probabilistic forecasts of load, variable renewables, and net-load power and ramps</p> <p>Use big data analytics as a tool for building data-driven forecasting models in addition to typical weather-forecasting models based on Numerical Weather Prediction</p> <p>Work with industry (independent system operators and utilities) to evaluate the value proposition of advanced forecasts and recommend best practices of forecast integration</p>

**Table 5. Gap analysis summary for data management, modeling, and analytics (continued).**

Gaps identified by working groups	Working groups	Potential approaches to address the gaps
<p><b>Optimal weather sensing for different smart grid applications</b></p> <p>Several grid modernization applications—such as state estimation, fault detection and system recovery, topology estimation and feeder reconfiguration, and stability assessments—benefit from timely, reliable, and accurate weather monitoring and forecasts. Their use can go beyond the power grid to operations and state estimation in interdependent systems such as transportation, gas, and water infrastructure. The challenge is to understand the requirements of weather data accuracy, quality, and reliability for these applications and develop cost-optimized systems for maximum observability and grid performance</p>	<p><b>Weather Data analytics Crosscutting</b></p>	<p>Develop hybrid (physics-based and data-driven) models that relate grid applications and weather-dependent parameter forecasts or state estimates</p> <p>Understand the impacts of varying reliability, data coverage, and sensing infrastructure cost on application performance</p> <p>Study the impact of the Pareto front of sensing infrastructure cost and reliability on grid performance</p> <p>Develop and enforce industry best practices for weather monitoring sensor deployment, maintenance, and operation (especially for remote locations)</p>

## **9. CROSSCUTTING ISSUES**

A number of capability gaps were identified as crosscutting. They could be categorized according to challenges associated with (1) cyber-physical security of the sensing and measurement system; (2) standardization of testing methods and ensuring that standards are continually being updated to reflect the state of the art in new technology deployment; (3) establishing tools and methods to more clearly demonstrate the value of advanced sensing and measurement technologies, data management systems, and data analytics in the context of particular grid applications; and (4) facilitating more rapid and widespread deployment of sensing and measurement technologies. Therefore, these gaps are grouped into the subcategories of Cyber-Physical Security; Standards, Testing, and Standardization; Value Proposition; and Facilitating Deployment of New Technologies.

### **9.1 CYBER-PHYSICAL SECURITY**

The primary capability gap in cyber-physical security is the lack of focused efforts specifically targeting cybersecurity aspects across the sensing and measurement infrastructure and for emerging specific advanced technologies. To address this gap, the team recommended the development of clear, standardized methodologies for assessing the cyber-physical security of emerging sensing and measurement technologies, including awareness of cyber-physical security as a key element of new R&D efforts focused on sensing and measurement technologies.

### **9.2 STANDARDS, TESTING, AND STANDARDIZATION**

A key capability gap identified was insufficient standards for addressing rapidly emerging concerns regarding the interoperability and resiliency of grid sensors. One example is the lack of a clear definition and standardized requirement of sensor resiliency in terms of qualified standard testing procedures and facilities. Another gap is the discrepancies in existing standards, which cause confusion in compliance when sensing and measurement devices are developed, tested, and deployed. In some cases, as a result, the relevant existing standards can be difficult to identify. In addition, the mechanisms for including emerging sensor technology platforms within new standards are less than ideal. Potential approaches to address these gaps include the development of a formalized partnership between the GMI/GMLC and relevant standards development organizations to enable collaborative interactions. Such a partnership could ensure that the needs of sensing and measurement technology within the electric grid application domain are being properly addressed. The team has also noted that when relevant standards are unclear or lacking in terms of data, communication, interoperability, or other factors, the deployment of advanced sensing and measurement technologies can be impacted.

### **9.3 VALUE PROPOSITION**

Another key capability gap related to the ubiquitous deployment of advanced sensing and measurement technology is the challenges associated with providing a clear valuation of the advantages that can be derived from the deployment of a specific technology or even a full sensor network solution. This gap is relevant for all aspects of an advanced sensing and measurement application, including devices, communication, analytical methods, advanced data management approaches and techniques, reliability and resiliency, maintenance and support, and regulatory impacts. Great challenges lie in determining accurate cost estimates for new or even existing technologies, as they may not be readily accessible and may be different for retrofits compared with new installations. Clarifying the valuation of sensor reliability, though difficult, could have a significant impact on the ability to clearly demonstrate the value of advanced technology deployment. It may be addressed in part through standardized testing approaches and through improving the understanding of full sensing and measurement costs via industry surveys and a database with cost information, including the details of installation, operation, and maintenance.

Another approach is to develop standardized, well-accepted methods for the valuation of innovative technologies. This approach might include grid modeling in conjunction with sensor placement and allocation tools applied to high-value use cases for which different sensing and measurement technologies and approaches can be compared on an equal basis. Such methods/tools could address sensor reliability and resiliency in addition to performance and cost to provide a convincing relative valuation for benchmarking. Reliability or resiliency may be difficult to estimate and quantitatively represent, but it is critically important for actual technology deployment. SPOT, developed under the parallel task<sup>20</sup> of this project, is an example of such tools. It is an application-based tool to optimize the placement (number and location) of sensors subject to application-specific objectives and constraints of physical placement and cost/budget. Current applications completed within this tool include distribution state estimation and system reconfiguration.

#### 9.4 FACILITATING DEPLOYMENT OF NEW TECHNOLOGIES

Several key capability gaps were identified related to the specific need to address nontechnical challenges to the deployment of new technologies by industry. One major gap is the need to provide industry with a voice so that challenges, concerns, and questions regarding the deployment of advanced technologies being developed can be heard and recognized and shared. NASPI has provided such a venue for the synchrophasor technology community. A formalized group could be established for the broader array of sensing and measurement technology in the future through the GMI/GMLC. For example, industry partners participating in the working groups pointed out that, in some cases, regulations that promote the replacement of larger capital grid assets may adversely impact the deployment of commercial and advanced sensing and measurement technologies. A venue for voicing such concerns, lessons learned, and other business challenges for new technology development and deployment can help better inform regulatory bodies regarding the relevant trade-offs, and thus have a significant impact. Another gap is the education and training associated with the deployment of new technologies. It is recognized that industry may not always have (1) full awareness of and (2) the human capital required to train personnel to efficiently use new systems. These gaps eventually diminish the overall value of the deployment. Approaches to addressing these gaps may include developing new curricula specifically focused on such topics, combined with collaboration between researchers and operators/industry focused on simplifying user interfaces for emerging technology platforms.

**Table 6. Gap analysis summary for crosscutting issues.**

Gaps identified by working groups	Working groups	Potential approaches to address the gaps
<b>Cyber-physical</b>		
<p><b>Lack of focused research targeting cyber-physical security aspects</b></p> <p>There is a lack of comprehensive research dedicated to cyber-physical issues of sensing and measurement systems, partially resulting from a lack of clear awareness of the level of cyber-physical security of these systems, and resulting impact assessments</p>	<b>Crosscut</b>	<p>Develop clear, standardized methodologies for assessing the cyber-physical security of emerging sensing and measurement technologies, including awareness of cyber-physical security as key elements of new R&amp;D efforts focused on these technologies</p>

<sup>20</sup> Task 3 of Project 1.2.5 GMLC Sensing and Measurement Strategy Project

**Table 6. Gap analysis summary for crosscutting issues (continued).**

Gaps identified by working groups	Working groups	Potential approaches to address the gaps
<b>Standards and testing and standardization</b>		
<p><b>Testing standards are insufficient for grid sensors</b></p> <p>There is a lack of standardized testing procedures and there are discrepancies in existing testing standards</p> <p>A clear definition of sensor resiliency and resiliency testing requirements are lacking</p>	<b>Crosscut</b>	<p>Work with standard development organizations to develop standard procedures and definitions</p>
<p><b>Accommodating new sensor technologies in existing and updated standards</b></p> <p>There are significant challenges to identifying existing applicable standards and interoperability requirements for emerging sensor technologies</p> <p>There are insufficient mechanisms to accommodate emerging sensor technologies in the development of new standards and/or updates or standards revisions</p>	<b>Crosscut</b>	<p>Leverage the ongoing effort by the GMLC Interoperability project to develop a roadmap for interoperability</p> <p>Work with standard development organizations to develop mechanisms to accommodate the incorporation of new sensors into new or revised standards</p>
<p><b>Lack of standardization inhibits new sensor deployment</b></p> <p>A lack of standardized data and communication protocols for new sensors inhibits new deployment, particularly for technologies installed outside the substation, to the point that interfacing with utility systems such as distribution management systems, energy management systems, and SCADAs is not trivial</p>	<p><b>Asset health</b></p> <p><b>Weather</b></p>	<p>Clarify and highlight the challenge of using new nonstandardized sensor protocols and data as a barrier to new technology deployment and implementation</p> <p>Work with utilities, independent system operators and distribution system operators to understand format variations and rationale, as well as develop frameworks for standardization</p> <p>Develop effective interfaces and protocols to link new sensors and data to existing tools and data used for power system monitoring and management</p>

**Table 6. Gap analysis summary for crosscutting issues (continued).**

Gaps identified by working groups	Working groups	Potential approaches to address the gaps
<b>Value proposition</b>		
<p><b>Lack of valuation for sensing and measurement technology including data management and analytics</b></p> <p>There is a lack of comprehensive capabilities and sophisticated tools to conduct valid technology valuation and regulatory analysis for emerging sensor, analytics, and communication technologies</p> <p>There are no standard reliable and defensible ways to evaluate the value of data management systems to justify their initial and ongoing costs</p>	<p><b>Crosscut</b></p> <p><b>Data management</b></p>	<p>Develop and define well-justified and standardized ways to express and calculate the value of improved sensing and measurement for the power system. Apply these in high-value use cases to develop models to calculate the value of sensing and measurement technology including sensors, communications, data management, and data analytics</p> <p>Pursue targeted deployment of new sensing and measurement technologies for high-value use cases to improve and validate technology valuation based upon developed tools and methods</p>
<p><b>Reliability metrics need to be justified and continually revisited</b></p> <p>Reliability metrics play a key role in proving value for new sensing and measurement technologies and must be defined and continually assessed as grid applications and technologies evolve</p>	<p><b>PMU</b></p>	<p>Develop cases and justifications for specified reliability metrics and define new metrics when they are absent. This approach must be considered with respect to current IEEE, NERC, and other standards</p>
<p><b>Existing sensors are plentiful but expensive, limiting deployment and thus visibility</b></p> <p>Many grid asset monitoring technologies exist, spanning transmission, asset monitoring, distribution, and end use; but their deployment, and ultimately visibility, is limited by integration, operability, and cost issues</p>	<p><b>Asset health</b></p> <p><b>Data analytics</b></p> <p><b>Novel transducers</b></p> <p><b>End use monitoring</b></p>	<p>Develop and maintain multi-tier cost and performance metrics to balance integration and performance versus cost trade-offs. The goal is to dramatically reduce the cost of existing performance and enable new lower-cost sensors with reduced but sufficient performance</p> <p>Develop analytics to leverage new and existing data sources among different sensors and technologies efficiently</p>
<p><b>Cost of existing technologies is difficult to collate and assess</b></p> <p>Cost data for existing sensors are incomplete or need to be updated—particularly those for operations and maintenance (O&amp;M). Cost metrics for new sensing technology may also require differentiation between new installations and retrofits. Sensor reliability also impacts costs and should be considered</p>	<p><b>PMU</b></p>	<p>Industry surveys for various technologies should be performed and databases should be maintained, without attribution to specific vendors. Reliability, installation, O&amp;M, and communication costs should be explicitly considered and factored into such surveys when possible to appropriately benchmark technologies</p> <p>An industry evaluation group could also be established to identify costs and test for reliability and performance</p>

**Table 6. Gap analysis summary for crosscutting issues (continued).**

Gaps identified by working groups	Working groups	Potential approaches to address the gaps
<p><b>Support for improved but pragmatic sensor allocation</b></p> <p>Once the taxonomy of available sensing resources, their cost, and their reliability is understood, the challenge is to develop cost-optimized systems for maximum observability and grid performance for various applications, subject to the reality of practical placement constraints</p>	<p><b>Weather</b></p>	<p>Study the impacts of sensing infrastructure cost and reliability on grid performance, including performance during severe events</p> <p>Develop flexible, broadly applicable algorithms to maximize the cost/benefit trade-offs for practical sensor network platforms considering the reality of constraints (e.g., budget, accessibility, safety, location) on sensor placement and installations</p>
<p><b>Facilitating deployment of new technologies</b></p>		
<p><b>Giving industry partners a voice</b></p> <p>Industry and utility partners should have a venue for communicating and voicing challenges that they experience related to deploying new sensing and measurement systems</p>	<p><b>Crosscut</b></p>	<p>The industry could set up a user group that involves utilities and industry manufacturers so that they can share lessons learned and other information to improve sensors and their use and deployment. For example, NASPI has provided such a venue for synchrophasor technology for a number of years</p>
<p><b>Regulations inhibiting deployment of sensing and measurement technologies</b></p> <p>Regulations, such as ones that promote replacement of large existing capital grid assets, can unintentionally adversely impact the deployment of existing and emerging sensing and measurement technologies to enable greater utilization of existing grid assets</p>	<p><b>Asset health</b></p>	<p>Provide a forum for discussing business model challenges for new sensor deployment by industry</p> <p>Develop materials that can inform regulating bodies about trade-offs between large capital replacements vs. additional sensing and measurement technologies to extract more value from existing assets</p>
<p><b>Coordination to fully leverage existing sensing and measurement resources</b></p> <p>Many existing sensing and measurement technologies are deployed ubiquitously throughout the electric power system on assets not controlled by the utility and without coordination with utility assets</p>	<p><b>Weather</b></p>	<p>Harness existing resources by providing venues for collaboration and information exchange, such as targeted consortia including key personnel responsible for data generation, communication, assimilation, and end use</p> <p>Facilitate public and private data partnerships, as well as compiled comprehensive documentation of disparate data resources by key measurement parameters</p>

## 10. CROSSCUTTING SENSING AND MEASUREMENT SUPPORT

As discussed in Section 9, a clear need exists for foundational efforts to support the successful technology development and deployment of advanced sensing and measurement tools and methodologies throughout the electrical grid infrastructure. **Therefore, the team recommends that a Crosscutting Sensing and Measurement support effort be established that spans the various research thrusts and initiatives.** The objective of this crosscutting effort is to raise awareness of identified issues that are common across different sensing and measurement areas, create a gateway for stakeholders to efficiently access the right expertise and resources to address the issues, and provide the support, technical or nontechnical, necessary to facilitate those efforts.

Based on the crosscutting issues and needs identified in the working group process, four crosscutting initiatives are recommended:

1. Cyber-physical Security Awareness and Support
2. Standards and Testing to Support Improvement of Sensor Performance, Reliability, Resiliency, and Interoperability
3. Valuation of Sensing and Measurement Technology
4. General Crosscutting Needs Support for Industry and Utility Partners in Technology Deployment

Initiatives 1–3 would focus on technical issues common across all types of sensing and measurement technologies covered in the report. Initiative 4 would be a long-standing venue to support industry and utility partners with general crosscutting needs, even after the activities of the other initiatives have been closed. The approaches for these initiatives can be summarized as reviewing and documenting existing knowledge; harmonizing existing requirements and standards; developing new definitions, standards, and tools/methods; and providing guidance and support. Some of the proposed development and analysis work can possibly be developed into future stand-alone projects (under GMLC or other funding support). Some can be related to or tied in with existing GMLC projects, the results and findings of which can be readily used to address the crosscutting issues. It is also possible for some of the proposed crosscutting activities to be merged or coordinated with existing efforts.

### 10.1 CYBER-PHYSICAL SECURITY AWARENESS AND SUPPORT

Sensing and measurement systems in the power grid are on the front lines of susceptibility to cyber-physical threats. However, awareness of the cyber-physical security issues of the sensing and measurement systems, in some sense, remains at a qualitative level, lacking in-depth understanding of challenges and technical details that are specific to sensing and measurement devices. The great diversity of sensors used in the power grid makes it more difficult to address these issues. Some sensors may have built-in cyber-physical security features. However, many sensors operating in the power grid contain numerous components; this increases their susceptibility and requires more sophisticated cyber-physical solutions. Therefore, room exists for top-down and comprehensive research on regarding the cyber-physical security of the power grid's sensing and measurement systems.

The primary capability gap within the area of cyber-physical security is the lack of focused efforts specifically targeting cybersecurity across the sensing and measurement infrastructure, as well as for specific advanced technologies that are emerging. To address this gap, the team recommends development of clear, standardized methodologies for assessing the cyber-physical security of emerging

sensing and measurement technologies, including awareness of cyber-physical security as a key element of new R&D efforts focused on sensing and measurement technologies.

This crosscutting initiative is to raise awareness of the cyber-physical security concerns of the sensor and measurement systems in the power grid by developing more technically oriented guidance and reference. The security challenges and gaps in the existing sensor infrastructure will be analyzed. Comprehensive cyber-physical requirements for sensor systems used in power grid applications will be summarized and documented. The initiative will also provide support to stakeholders (mostly the corresponding researchers, sensing technology developers/vendors, and sensor system users) in improving the security of existing sensor and measurement infrastructure and developing new sensor projects with built-in reinforcement of cyber-physical security. It will facilitate the communication channels needed to bring the right expertise and resources to stakeholders to address the cyber-physical vulnerabilities regarding sensing- and measurement-based applications in the power grid. An existing GMLC project related to cybersecurity is as follows:

GMLC Project 1.4.23, Threat Detection and Response with Data Analytics, is to develop advanced analytics on operational cyber data to detect complex cyber threats in the power grid. This project will help power operators differentiate between cyber-caused and non-cyber-caused incidents—for example, physical attacks or natural hazards. It may also provide a tool to support the cyber-physical security needs discussed in this crosscutting initiative.

## **10.2 STANDARDS AND TESTING TO SUPPORT IMPROVEMENT OF SENSOR PERFORMANCE, RELIABILITY, RESILIENCY, AND INTEROPERABILITY**

While concerns regarding interoperability and resiliency rapidly grow in the context of making the power grid more flexible and resilient, great insufficiency remains in the existing standards and testing procedures for grid sensor interoperability and resiliency. There is a lack of clear definition and standardized requirements for sensor resiliency in the form of qualified standards, testing procedures, and facilities. Unique DOE laboratory facilities can potentially help to support the testing and standard development efforts in this area, in collaboration with other organizations.

The types of sensors used in the power grid and their communication setups vary significantly based on their application. This variability results in complications in identifying the appropriate standards and interoperability requirements with which sensing and measurement technologies and their deployment should be compliant. This is especially true for emerging technologies and advanced sensors. There are discrepancies in existing testing standards, causing confusion regarding compliance when the sensing and measurement device is developed, tested, and deployed. On the other hand, the development of new standards and interoperability requirements should account for emerging technologies and trends. Unfortunately, the mechanisms for including emerging sensor technology platforms within the process for developing new standards are less than ideal.

This crosscutting initiative will target the establishment of standardized definitions, methodologies, and procedures for the benchmarking and testing of the functional performance, reliability, and resiliency (in the presence of extreme natural or human-caused events) of sensors before full deployment occurs. Also included is the development of a formalized partnership between the GMI/GMLC and relevant standards development organizations. Coordination between the two organizations will enable collaborative interactions that can ensure that the needs for sensing and measurement technology within the electric grid application domain are properly addressed. Also, existing standards can be harmonized to eliminate discrepancies. These activities will also promote the establishment of a database of testing facilities with comprehensive capabilities in performance and reliability testing, as well as intrusive testing to validate

sensor resiliency. Finally, strategic partnerships with private and public-sector partners will establish access to relevant testing facilities.

Within GMLC, several ongoing projects related to this initiative have been identified:

- GMLC Project 1.2.2 Interoperability—The objective is to articulate general interoperability requirements along with methodologies and tools for simplifying the integration and cyber-secure interactions among various devices and systems. It will involve establishing a strategic vision for interoperability, measuring the state of interoperability in technical domains, identifying gaps and roadmaps, and ensuring industry engagement.
- GMLC Project 1.4.1 Standards and Test Procedures for Interconnection and Interoperability—The objective is to help develop and validate interconnection and interoperability standards for existing and new electrical generation, storage, and loads. The activity will ensure cross-technology compatibility and harmonization of jurisdictional requirements, and ultimately will enable high deployment levels without compromising grid reliability, safety, or security.
- GMLC Project SI-1695 Accelerating Systems Integration Codes and Standards—The objective is to update the standards identified under the grid performance and reliability topic area, focusing on the distribution grid. Also, this project will establish accelerated development of new interconnection and interoperability requirements and conformance procedures, which is the key project result.
- GMLC Project 1.2.3 Grid Modernization Laboratory Consortium Testing Network—The objective is to close the gap in accessibility to validated models for grid devices and simulation tools and corresponding full documentation. The project will drive the standardization and adoption of best practices related to device characterization, model validation, and simulation capabilities through facilitated industry engagement. Some of the project’s findings may help address the testing issues brought up in this crosscutting initiative.

### **10.3 VALUATION OF SENSING AND MEASUREMENT TECHNOLOGY**

Clear valuation is among the defining factors by which utilities make decisions on adopting advanced sensing and measurement technologies. Valuation is relevant for all aspects of a sensor application, including devices, communication, analytical methods, advanced data management approaches and techniques, reliability and resiliency, deployment, maintenance and support, and regulatory impacts. Successful valuation usually involves extensive analysis and quantitative modeling of technical and economic risks and benefits. However, significant challenges exist in providing accurate cost estimates for new or even existing technologies, as they may not be readily accessible, and costs may be different for retrofit projects compared with new installations. The costs and benefits due to some factors, such as sensor reliability and resiliency, are even more difficult to quantify; but they could have a significant impact on the ability to clearly demonstrate the value of advanced technology deployment. In current practice, the lack of comprehensive capabilities and sophisticated tools to conduct valid valuation is a major barrier to promoting new technology. In addition, regulation may affect technology adoption and deployment, making the analysis more complicated. For example, regulatory incentives can encourage the adoption of new technologies, whereas regulatory restrictions may induce extra costs and discourage adoption.

Standardized testing approaches, industry surveys, and a cost information database (including the details of approval, installation, operation and maintenance, and so on) may improve understanding of total sensing and measurement costs. The development of standardized, well-accepted methods/tools for the valuation of technologies also is necessary. The methods/tools may integrate grid modeling with sensor

placement and allocation capabilities, which can facilitate comparisons among different sensing and measurement technologies on an even basis. Such methods/tools should address sensor reliability and resiliency in addition to performance and cost to provide a convincing relative valuation for benchmarking, as reliability or resiliency may be difficult to estimate and represent quantitatively but are critically important for actual technology deployment. SPOT as mentioned earlier is an example of such a tool.

This crosscutting initiative is to support the adoption of sensing and measurement technologies by promoting capabilities and methodologies for improved valuation. It will promote the establishment of expertise and capabilities both internal and external to the DOE national laboratory system to facilitate technology valuation, regulatory analysis, and risk evaluation of sensor deployment projects. Relevant methods, tools, research efforts, and best practices will be identified and categorized with up-to-date contact information, and the results will be made accessible for the stakeholders.

Some ongoing projects within GMLC are related to the topic of this initiative, the findings and results of which might be worth consideration for the proposed work of this initiative. GMLC Project 1.2.4 and 1.4.29 are two examples. Project 1.2.4, Grid Services and Technologies Valuation Framework, is to address the inconsistencies and lack of transparency across existing valuation methodologies by developing a comprehensive and transparent framework to value the services and impacts of grid-related technologies. The valuation framework must be useful to assess “regulated investments” as well as investments by private sector entities. The proposed valuation framework might be used for sensing and measurement technologies. Project 1.4.29, Future Electricity Utility Regulation, assists states in addressing regulatory, rate-making, financial, business models, and market issues related to grid modernization in the power sector. It will also help link utility earnings to consumer value, economic efficiency, and other public policy goals. Some findings of the project may directly benefit this crosscutting initiative by providing answers to issues such as how to adapt electric utility regulation and rate-making to new technologies and services, assess potential financial impacts on utility shareholders and customers, invest in infrastructure that enables customer engagement, and how to provide incentives to utilities to achieve grid modernization goals.

#### **10.4 GENERAL CROSSCUTTING NEEDS SUPPORT FOR INDUSTRY AND UTILITY PARTNERS IN TECHNOLOGY DEPLOYMENT**

Beyond the aforementioned initiatives and activities, there is a need for long-term and continuous efforts to support the industry and utility partners in some general crosscutting issues. Examples may include continuous maintaining and updating of contact information, expertise lists, and technology databases, and providing support for recurring events (e.g., industry meetings/workshops). Also, some new crosscutting needs, such as expertise matchmaking, may arise on a project-by-project basis. Therefore, having a standing mechanism, which is missing in the current setup, to support those needs is necessary and can be beneficial in the long run. Such an initiative is recommended.

Several key capability gaps were identified related to the specific need to address nontechnical challenges concerning the deployment of new technologies by industry. One major gap is the need to provide industry with a voice so that challenges, concerns, and questions regarding the deployment of advanced technologies being developed can be heard and recognized. For example, industry partners pointed out that in some cases regulations that promote the replacement of large capital grid assets can adversely impact the deployment of existing and advanced sensing and measurement technologies. A venue for voicing such concerns and other business challenges for new technology development and deployment can inform regulatory bodies regarding relevant trade-offs and thus have a significant impact. Another gap is the education and training associated with the deployment of new technologies.

This crosscutting initiative is to provide a long-standing mechanism to support industry and utility partners in general crosscutting needs induced by sensor deployment. As mentioned earlier, a formalized group could be established for the broader array of sensing and measurement technologies in the future through the GMI/GMLC. This initiative will promote the establishment of relationships and partnerships among the research, academia, industry, utility, and regulation communities. It is expected to provide a standing venue for stakeholders to voice the challenges they face in developing and deploying new sensing and measurement technologies within their systems. The establishment of two-way communication between regulation-makers and stakeholders would help resolve misunderstanding and inconsistency to accelerate technology adoption and deployment. Regular workshops with industry and utility partners would maintain a working knowledge of barriers preventing new sensing and measurement technology deployment. At these meetings, lessons learned and needs for new expertise and facilities could be communicated with DOE and GMLC leadership to identify opportunities where resources within the DOE system can be leveraged to provide assistance.

## **11. HIGH-VALUE USE CASES AND THE EXTENDED GRID STATE DEFINITION**

The EGS definition derives from the concept that the state of the grid consists of more than a set of electrical measurements (i.e., those of a state estimator, for those familiar with this technology). The EGS includes traditional electrical aspects as well as markets, communications, utility asset states, and ambient conditions such as weather and other environmental factors. The EGS provides a holistic basis on which to map scenarios and use cases to examine utility sensing and measurement to enhance grid reliability and resiliency and provide direction for future R&D. A set of eight use cases was developed by the team for focusing on, exploring, and demonstrating the need for a sensing and measurement strategy relevant to the roadmap development.

A complete description of these use cases is presented in Appendix E. They include

1. Fault Detection, Interruption, and System Restoration
2. Incipient Failure Detection in Electrical Grid Assets
3. Sensing and Measurement Technology to Mitigate or Prevent Impacts of Cyber or Manmade Attacks
4. Integrating Advanced Resource Forecasts for T&D Grid Operations
5. Topology Detection within the Distribution System.
6. Sensing and Measurement Technology to Mitigate Impacts of Natural Disasters and Enhance Grid Resilience
7. Optimizing Grid Operation with Enhanced Data Spanning Transmission, Distribution, and Generation
8. Detection of Energy Theft and Unregistered DER

Of these developed use cases, the three highest priority cases are 1, 2 and 3. They have been further developed based on their potential impact, diverse characteristics, and differing EGS utilization.

The following sections describe each high-priority use case in terms of the latest EGS framework version.

### **11.1 FAULT DETECTION, INTERRUPTION AND SYSTEM RESTORATION**

The detection and interruption of faults and the restoration of the power system after disruptions is key to ensuring the reliability of distribution systems. The evolution of the smart grid with high penetration levels of DERs makes it more challenging to maintain the high level of reliability that we have today. Thus, it is critical that protection devices be both properly and adequately placed and their protection settings adjusted as the state of distribution circuits varies with the changing status of DERs on the circuit. Widespread deployment of these devices also requires advances in distributed communications architectures and efficient data management. Fault detection, interruption, and system restoration technologies that employ both switchgear and control logic are deployed to provide more reliable power to distribution systems. However, there is no existing methodology for the systematic deployment of these devices; only rule-of-thumb methods are currently used by engineers, such as the placement of two or more of these devices on long distribution circuits. There is also no existing methodology for the placement of this technology to take into account various levels of distributed resources in the system, which impact protection device locations and settings. A sensor optimization placement framework and tools for determining how fault detection, interruption, and system restoration devices—such as

intelligent recloser—should be developed. Doing so will achieve optimal reliability on distribution systems both with and without distributed resources. Figure 5 shows how this use case relates to the EGS.

## **11.2 INCIPIENT FAILURE DETECTION IN ELECTRICAL GRID ASSETS**

Early detection of incipient failures at and within electrical grid assets is a ubiquitous need throughout the electrical grid infrastructure. For many critical assets, sensing and measurement device technologies exist. Reducing costs, or increasing the overall valuation proposition, and improved data analytics methodologies should be studied. Machine learning methods can improve deployment and performance, and enable successful detection of incipient faults on the broadest possible range of grid assets. Figure 6 shows how this use case interfaces with the EGS. The general idea encapsulated in this figure is to merge measurements taken from the operational electrical system with structural information about the components and asset information about the history and life cycle of a component or asset, possibly enhanced by novel sensors to directly measure the properties of their condition. The information would be merged through analytical methodologies to enable forecasts and observations regarding probable or imminent component/asset failures before equipment failure and to provide information to geospatial databases. Such information could improve the performance of operations and maintenance programs and proactively mitigate outages versus reactively responding to them after the fact.

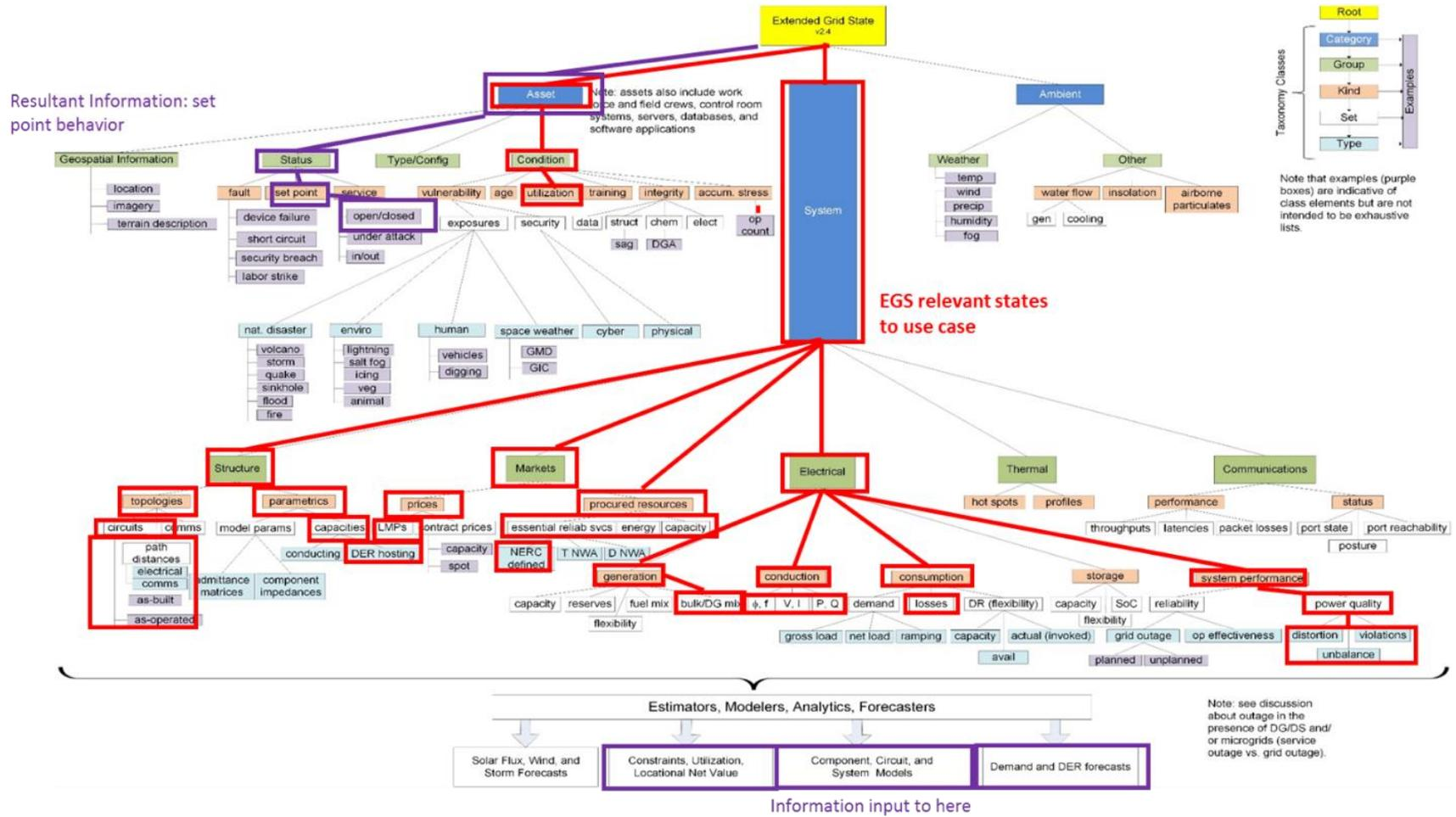

Figure 5. EGS relevance to fault detection, interruption, and system restoration.<sup>21</sup>

<sup>21</sup> Extended Grid State Definition Document, prepared by the GMLC Sensing & Measurement Strategy Project, PI: D. Tom Rizy, Task Lead: Jeff Taft, Version 3.2 current draft, to be published as a PNNL and GMLC Report.

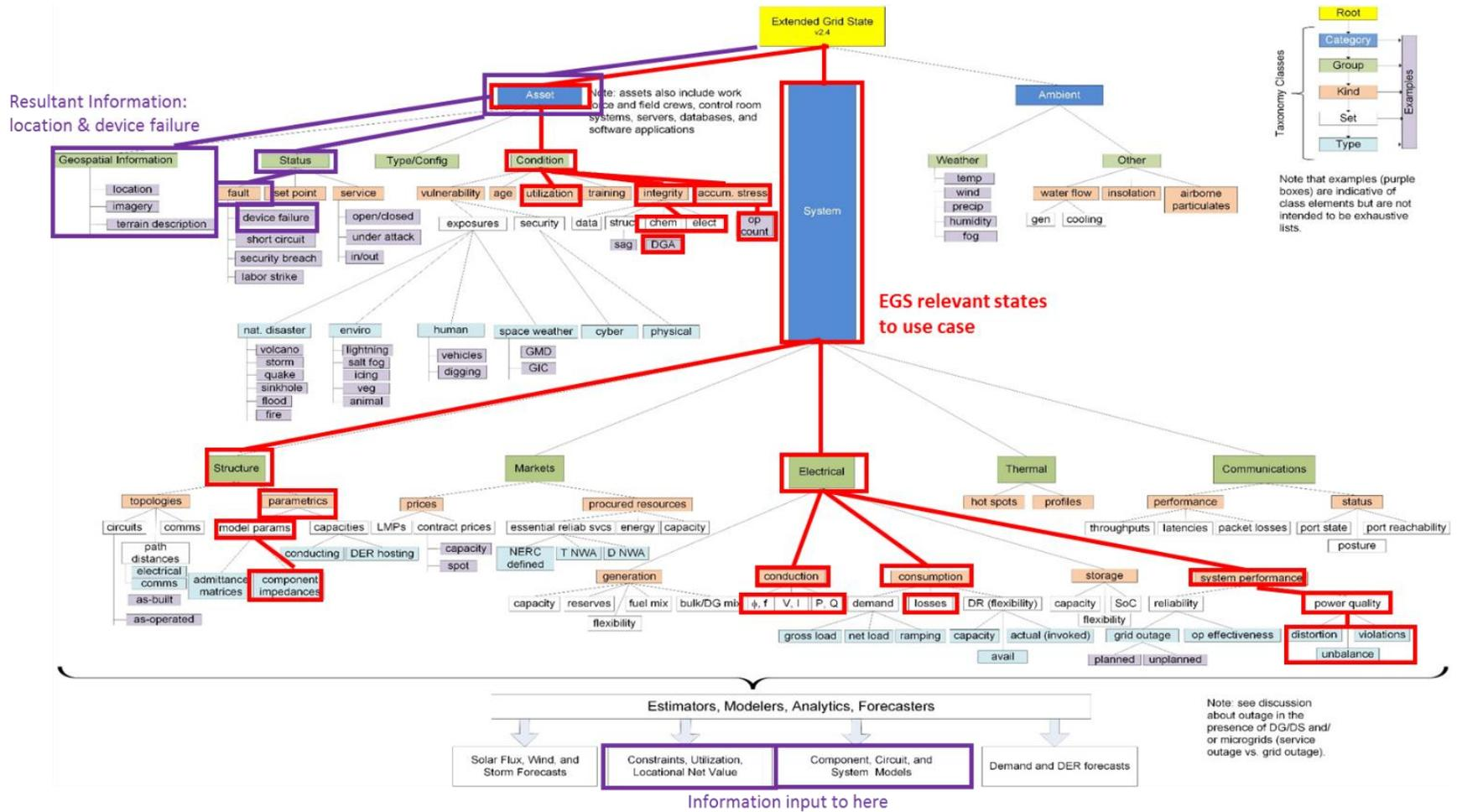

Figure 6. Extended grid state relevance to incipient component failure.<sup>22</sup>

<sup>22</sup> Extended Grid State Definition Document, prepared by the GMLC Sensing & Measurement Strategy Project, PI: D. Tom Rizy, Task Lead: Jeff Taft, Version 3.2 current draft, to be published as a PNNL and GMLC Report.

### **11.3 SENSING AND MEASUREMENT TECHNOLOGY TO MITIGATE AGAINST IMPACTS OF NATURAL DISASTERS AND ENHANCE GRID RESILIENCE**

Recent severe power outages caused by extreme weather hazards highlight the importance and urgency of improving the resilience of the electric power grid. Improving the speed and efficiency of distribution system restoration can play a key role in enhancing grid resiliency against natural disasters. One key challenge for distribution system management and restoration during natural disasters is improved situational awareness of the operational state and damage status. An increased awareness of the EGS resulting from sensor technology and data fusion would improve operations, planning, management, and restoration throughout the course of a major grid event. Achieving this awareness requires sensing the ambient conditions under which a grid operates, integrating the available resources and assets, and continually monitoring the electrical and communication states of the grid. Such a coherent understanding of the grid in challenging conditions is possible only through detailed measurements and analytics defined by the EGS. Figure 7 shows this use case.

### **11.4 SUMMARY OF USE CASES**

The three high-value use cases described highlight the importance of the EGS definition in addressing challenging grid problems. These problems cannot be adequately addressed without a holistic view of the grid via the use of advanced sensors and data analytic techniques. In these use cases and many others, a coherent understanding of the state of the grid improves grid reliability in ways that are not otherwise achievable. Complete visibility of the state of the grid can be achieved only through novel inexpensive/high-value sensing and measurement technology, reliable and secure communication, coherent and efficient data management, and novel data analytics techniques.

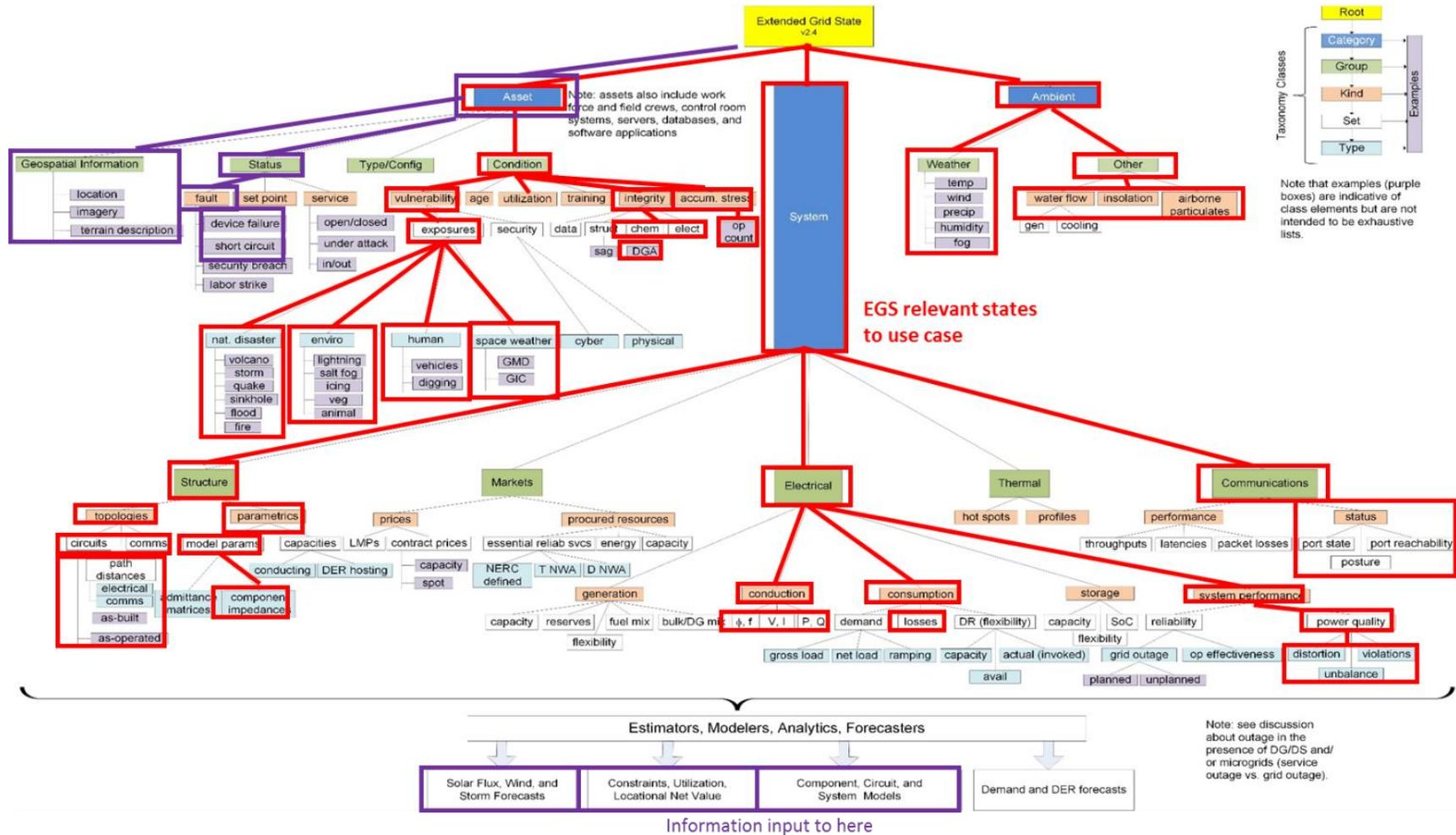

Figure 7. Extended grid state relevance to natural disaster mitigation.<sup>23</sup>

<sup>23</sup> Extended Grid State Definition Document, prepared by the GMLC Sensing & Measurement Strategy Project, PI: D. Tom Rizy, Task Lead: Jeff Taft, Version 3.2 current draft, to be published as a PNNL and GMLC Report.

## 12. KEY FINDINGS AND PROPOSED FEDERAL EFFORTS TO ADDRESS GAPS

Based on the identified capability gaps summarized in Section 9, and described in more detail in the individual working group summary reports of Appendix D, the overall industry partner/stakeholder and national lab team has developed potential initiatives and research thrusts that may require federal investment/participation to be achieved. The working group leads were also asked to recommend relative priorities based upon the information gathered during their respective working group processes. These recommendations are included within the detailed working group reports in Appendix D. The proposed initiatives and thrusts were then further prioritized according to working group and stakeholder engagements. (The most recent one was an in-person workshop held at Southern Company in Atlanta, Georgia, in spring of 2018.)

The key findings are summarized in this section. The full set of research thrusts, along with targets, timelines and relative rankings and prioritization, are presented in Section 13. The key findings are grouped into (1) Uses and Sensing Technology Targets, (2) Communications and Networks, and (3) Data Management and Analytics and Modeling.

### 12.1 USES AND SENSING TECHNOLOGY TARGETS

1. Many commercial technologies exist, yet deployment is limited by the total overall cost (equipment and installation) of implementing sensing technologies and the return on investment perceived by the owner of the assets to be monitored. ***In order to enable and accelerate new sensing technologies, federal research efforts should specifically target (a) dramatic cost reductions for equipment with performance comparable to that of existing commercial technologies and (b) extremely low-cost (e.g. less than between \$1 to \$100 per node or sensing location) sensing approaches that enable access to parameters of interest with adequate but reduced overall performance levels.***
2. Enabling technologies such as advanced sensing materials and scalable low-cost manufacturing methods can significantly impact the performance and cost of advanced sensing devices, and are a core capability of the DOE national laboratories. ***Federal research efforts should specifically leverage DOE laboratory and other capabilities in advanced materials and advanced/additive manufacturing methods for developing novel multi-modal and multi-parameter, low-cost sensor platforms that meet specified cost and performance targets.***
3. Generation assets, such as fossil and nuclear-based plants, impose extreme performance constraints on asset health monitoring sensing technologies due to operational temperatures, pressures, erosive/corrosive conditions, and potential for radiation exposure. ***Federal research efforts on asset health monitoring of conventional generation assets should specifically target high-temperature (e.g. 500 to 1500°C or higher) and harsh environmental performance operational conditions (e.g. corrosive, erosive, and radiation) with cost as a secondary consideration.***
4. Temperature is a key parameter in the early identification of faults and failures in assets across the modern power system. ***Federal research efforts should target novel temperature-sensing approaches for internal asset monitoring through emerging technologies with unique characteristics, such as compatibility with deployment internal to both electrical grid and generation assets.***
5. Electrical parameter measurements can provide the most rapid signatures of low-probability, high-consequence events, such as physical (i.e., human-caused) or natural events, to enable preventative action that can prevent large-scale failures and minimize impacts to achieve grid resiliency. Abnormal behavior (such as failures, faults, or severe degradation of performance of an asset) also often

manifests itself by deviation from nominal grid operating frequency or by the occurrence of abnormal frequencies (such as previously unexperienced or undetected harmonics or frequency characteristics). ***Federal research efforts should target rapid, high-bandwidth and low-latency electrical parameter measurements, including novel frequency-selective sensors that can provide fundamentally new information.***

6. A unique value proposition exists for asset health-monitoring sensors that (1) are capable of monitoring multiple parameters of interest simultaneously (e.g., temperature, pressure, and gas phase chemistry), (2) are compatible with internal electrical and generation asset deployment, and (3) enable spatially distributed measurements. ***Federal research efforts should target sensor technology platforms with these unique characteristics, such as optical and passive wireless sensor device technologies and areal imaging-based techniques.***
7. Indirect measurements of proxy parameters that are relatively easy and inexpensive to implement are often sufficient. They can take measurements external to an asset and can provide insights about asset health and faults/failures. ***Federal research efforts should encourage development of ultra-low-cost proxy-based sensing platforms (e.g. acoustic, ultrasonic, and corrosion proxy sensors at \$1 per node).***
8. Wireless, self-powered, self-configuring, self-commissioning, and self-calibrating sensors for building efficiency will be necessary for future transactive controls. ***Federal research efforts should target development of low-cost, wireless, self-powered, self-calibrating, and multicomponent integrated sensors for large-scale deployment.***
9. Electricity, temperature, luminance, air quality, building occupancy, and so on are measured by different types of equipment and are typically not correlated for advanced functions like fault detection and diagnosis (FDD) of building equipment. ***Federal research efforts should encourage development of multi-sensor integrated measurement devices that are passive or self-powered, interactive, and intelligent for comprehensive self-learning/adaptive controls.***
10. It is vital to consider the vast amount of existing weather-monitoring sensor and measurement infrastructure, in conjunction with possible newer infrastructure, and find ways to harness them for various types of advanced grid modeling and operational integration. ***Federal research efforts should target the development of low-cost scalable weather sensors, high-quality and portable calibration techniques, and more optimal utilization of existing weather-monitoring infrastructure for data-driven advanced system modeling. Advanced modeling and integration needs include load dynamics and forecasts; probabilistic renewable energy forecasts; strategic planning against natural disasters for grid resilience; and integration of advanced forecasts into energy management and distribution management systems operation for economics, lean reserves, and reliability.***

## 12.2 COMMUNICATION AND NETWORKS

1. Utilities have deployed communication networks that support their present operations and in most cases not ones that enable widespread use of sensors. ***Federal research efforts should target design and development of a cost-effective, scalable communications fabric to support the wide range of next-generation sensors, systems, and DER, electric vehicle, and responsive load components.***
2. The IIoT and 5G wireless activities under way in the private, public, and academic sectors present an array of concerns for electric utilities, including changes in the supervisory control and data acquisition/incident command system (SCADA/ICS) architecture, cybersecurity vulnerabilities, and

use of the Cloud for data archiving and operations. ***Federal research efforts for designing a distributed communications architecture that supports these technology developments as well as provides cybersecurity is under way and should continue.***

3. Electrical parameter measurements can provide the most rapid signatures of low-probability, high-consequence events, such as physical (human-caused) or low-occurrence natural events, to enable actions that can prevent large-scale failures and minimize impacts that degrade grid resiliency. ***Federal research efforts should target development of scalable, rapid, high-bandwidth and low-latency communication networks to support cybersecure transport of data associated with electrical parameter measurements.***
4. Optimal spectrum utilization remains a challenge to be addressed, as many distinct grid sensors are deployed across the modern electric power system. In addition, flexible, scalable, and dynamic architectures are required to support the needs of such sensor deployments. ***Federal research efforts should target spectrum utilization challenges, including distributed scheduling schemes and distributed intelligence, as well as dynamic resource allocation.***
5. The uncertainties and security risks associated with networking techniques should be addressed. Cybersecurity and data privacy should remain key factors in the development and implementation of new technologies and networks. ***Federal research efforts should quantify network uncertainties and security risks in the context of the modern electric power system and develop self-healing and more robust network capabilities to oppose malicious operations.***

### **12.3 DATA MANAGEMENT AND ANALYTICS INCLUDING GRID MODELING**

1. Considerable amounts of R&D are occurring at many institutions. These include commercial, educational, and government-sponsored R&D into data management, and various technologies for dealing with data. Numerous technologies of various kinds were noted by the working groups. However, few of them are making their way into power grid operations for three reasons: cost justification, workforce education, and standardization. ***Federal research efforts for data management in the utility sector should specifically focus on addressing these gaps.***
2. A primary reason why more advanced data management and analytics are not being used by operators for grid operations is that the displays and indicators are not usable or desirable in a grid control room (because operators already have too much information output to monitor). Control room operators are required to perform decision actions when new tools are introduced, so there is a high bar for getting new tools/displays introduced. This situation highlights a disconnect between researchers and operators about how humans operate in the control room environment. ***Federal research efforts on data management for grid visibility should include a focus on human-machine interactions with visualization and should engage operators early in the development process.***
3. Data preparation (e.g., data format, quality) is a key limitation for data analysis and should be considered a key gap within data analytics rather than the analytics themselves. ***Federal research efforts should target efforts to standardize data formats and interfaces, as well as develop and apply techniques for data quality monitoring and processing in real time.***
4. Multimodal and multivariate analyses, integrating new sensing types and considering synchronization and reconciliation of these data sets, would be a valuable contribution. ***Federal research efforts should target development and application of data analytical methods that enable coupling of sensors of varying types and time synchronization to accomplish the desired objectives of operating and planning a modern electric power system.***



### 13. PROPOSED RESEARCH THRUSTS INCLUDING METRICS

In light of the key findings and capability gaps identified in earlier sections and explained in more detail in the appendices, a number of specific research initiatives/thrusts were developed as potential federal/industry R&D endeavors to fill these gaps. The research initiatives—in the cases of crosscutting needs and R&D thrusts and of devices, communications, and data analytics—include rationale, scope of proposed activities and, where possible, identifiable quantitative metrics. Linkages with the EGS as well as the desired attributes of a modern electric grid are also identified. A suggested timeline for the proposed research efforts and prioritization (1–5, with 1 being the highest priority) across all focus areas as well as a ranking within each focus area were also determined via working group activities. This information is provided in a graphical timeline at the end of each focus area.<sup>24</sup> Targets, timelines, and recommendations were developed by the working group leads in close consultation with key stakeholders from industry, utility, government, academia, and the DOE laboratories through the working group processes identified in Appendix D. It is anticipated that these suggested R&D efforts (initiatives and thrusts) will serve as useful input to both DOE and industry for future decisions and plans regarding sensing and measurement technology development for grid modernization.

---

<sup>24</sup> This is a modification of the approach taken in the EPRI Transmission and Substation Area Roadmap documents.

## CROSSCUTTING INITIATIVES

The objective of this crosscutting effort is to raise awareness of the identified issues that are in common across different sensing and measurement areas; create a gateway for stakeholders to efficiently access the right expertise and resources to address the issues; and provide support, technical or nontechnical, necessary to facilitate those efforts.

### **1: Cyber-Physical Security Awareness and Support**

Raise awareness of the cyber-physical security of the sensor and measurement systems in the power grid. This effort will also provide support to stakeholders (mostly the corresponding researchers, sensing technology developers/vendors, and sensor system users) in improving the security of existing sensor and measurement infrastructure and developing new sensor projects with built-in reinforcement of cyber-physical security.

**Scope of activity:** (1) Analyze the security challenges and gaps in existing sensor infrastructure. (2) Summarize the cyber-physical requirements for sensor systems used in power grid applications. (3) Facilitate the communication channels to bring the right expertise and resources to the stakeholders to address the cyber-physical vulnerabilities regarding sensor and measurement applications in power grid.

### **2: Standards and Testing to Support Improvement of Sensor Performance, Reliability, Resiliency, and Interoperability**

(1) Target the establishment of standardized definitions, methodologies, and procedures for the benchmarking and testing of sensor functional performance, reliability and resiliency (in the presence of extreme natural or human-caused events) before engaging in the full deployment phase. (2) Develop a formalized partnership between the

GMI/GMLC and relevant standards development organizations to enable collaborative interactions that can ensure the needs for sensing and measurement technology within the electric grid application domain are being properly addressed. (3) Harmonize existing standards to eliminate discrepancies. (4) Promote the establishment of a database of testing facilities with comprehensive capabilities in regular performance, reliability tests, and intrusive tests to validate resiliency. (5) Establish strategic partnerships with private- and public-sector partners to enable access to relevant testing facilities.

**Scope of activity:** (1) Define standardized definitions, methodologies, and practices for benchmarking and testing of sensor performance, reliability, and resiliency. (2) Harmonize existing testing standards to eliminate discrepancies. (3) Maintain an up-to-date understanding of standards and testing facilities that have comprehensive capabilities. (4) Develop strategic partnerships with private- and public-sector partners to enable access to relevant testing facilities. (5) Provide technical input into new standards through active participation and engagement. (6) Develop sensor-specific working groups and consortiums for measurement quality assurance and format standardization for utility integration.

### **3: Support for Sensing and Measurement Technology Promotion and Deployment**

(1) Support the adoption of sensing and measurement technologies to promote the capabilities and methodologies for improved valuation. (2) Promote the establishment of expertise and capabilities both internal and external to the DOE national laboratory system to facilitate technology valuation, regulatory analysis, and risk evaluation of sensor deployment projects. (3) Identify and categorize relevant methods, tools, research efforts, and best practices with up-to-date contact information, and make accessible for stakeholders.

**Scope of activity:** (1) Identify and categorize relevant capabilities, tools, research efforts, and best practices for technology valuation with up-to-date contact information, and make these results accessible to the stakeholders. (2) Promote the development of methods/tools that can integrate grid modeling with sensor placement and allocation capabilities to address valuation of sensor reliability and resiliency. (3) Conduct detailed value proposition analysis that considers multiple value streams for different stakeholders, various different sensing technologies to ensure grid and resource visibility, and a Pareto front of solutions that varies in costs and benefits. (4) Analyze the impact of varying levels of sensing systems performance on grid economics and reliability.

### **4: General Crosscutting Support for Industry and Utility Partners**

(1) Provide a long-standing mechanism to support industry and utility partners in general crosscutting needs for sensor deployment. (2) Promote the establishment of relationships and partnerships among the research, industry, utility and regulation communities. (3) Provide a standing venue for stakeholders to voice the challenges they face in the development and deployment of new sensing and measurement technologies within their systems.

**Scope of activity:** (1) Hold regular workshops with industry and utility partners to maintain a working knowledge of barriers preventing new sensing and measurement technology deployment. (2) Share lessons learned and needs for new expertise and facilities with DOE and GMLC leadership to identify opportunities where technical resources within the DOE system can be leveraged to provide assistance. (3) Establish two-way communication between regulation-makers and stakeholders to help resolve misunderstanding and inconsistency to accelerate technology adoption and deployment.



## DEVICES

### Harsh Environment Sensors—R&D Thrusts

Flexible operation of conventional power plants refers to the potential of fossil and nuclear energy to serve applications other than their traditional baseload operations as part of the grid modernization strategy. In addition to baseload and spinning reserve (which applies to gas- and coal-fired generation), power plants can provide additional services through flexible operation. For example, plants can follow the variability of responsive load and renewable energy; provide ancillary services, provide spinning and non-spinning reserve capacity; reduce peak load; and controllably interact with newer grid assets such as energy storage and demand response. There is also the potential for nuclear- and fossil-based generators to be built as smaller plants closer to the distribution system and provide the variety of services mentioned previously, including as baseload sources. Newer services will require that such plants be flexibly operated over a wider range of operating capacities and for more extreme swings (increasing and decreasing) in power ramp rates, while maintaining reasonable costs, reliability, emissions levels, and energy efficiency and while not impacting component lifetimes. Enhanced capabilities for internal monitoring of power generation processes in real time enable advanced control strategies and enable the development of conventional plant designs to reduce any potentially adverse impacts on the generators, as well as more rapid adoption of newer technologies compatible with energy-efficient and flexible operation.

In many cases, high temperatures and harsh environmental conditions, which consist of highly corrosive and oxidizing gas species, present significant challenges for conventional sensors and instrumentation systems. In the case of nuclear power plants, radiation hardening of emerging instrumentation systems is an additional challenge that must be addressed.

**Key measurement parameters:** Temperature, pressure, chemistry, emissions, flow rate, heat flux, flame characteristics, mechanical performance (stress, strain, deformation, vibration, acceleration), current, voltage, frequency, real and reactive power, neutron and gamma flux (intensity and energy spectrum), radiation detection (specific to nuclear systems only).

#### **1: Harsh Environment Sensing for Real-Time Monitoring**

Harsh-environment embedded sensor technology is required for monitoring of conventional generation processes to enable the optimized flexible operation needed for a modern electrical power system operation.

**Key measurements:** Chemistry, temperature, pressure, heat flux, flow rate, mechanical performance

#### **Key metrics:**

Temperatures (700–1800°C), chemistry (H<sub>2</sub>, CH<sub>4</sub>, O<sub>2</sub>, CO, CO<sub>2</sub>, sCO<sub>2</sub>, N<sub>2</sub>, NO<sub>x</sub>, SO<sub>2</sub>, volatile matter), pressures (up to ~10<sup>7</sup>Pa), cost (varies), durability (component lifetime, maintenance intervals, or specified replacement period)

**Attributes:** Flexibility, resiliency, sustainability

**EGS level:** Component state

**Scope of activity:** Conduct sensor device technology development at laboratory scale, followed by pilot-scale deployment and testing, leading ultimately to technology transition to industry.

#### **2: Advanced Electromagnetic Diagnostic Techniques**

Develop electromagnetics-based diagnostic approaches needed to enable real-time monitoring of generation processes, for example, through access ports or using tomography-based techniques.

**Key measurements:** Solid flow, particulate characterization, temperature, current density

#### **Key metrics:**

Cost (varies), temperatures (700–1800°C), current density (A/cm<sup>2</sup>), particle size (micron to mm), resistance to port contamination

**Attributes:** Flexibility, resiliency, sustainability

**EGS level:** Component state

**Scope of activity:** Conduct sensor device technology development at laboratory scale, followed by pilot-scale deployment and testing, ultimately leading to technology transition to industry.



## Grid Asset Health Performance Monitoring—R&D Thrusts

Monitoring to determine asset health condition can be applied to all assets within the electrical power system. Benefits derived from improved visibility of asset condition and health include increased reliability and resilience through prevention of catastrophic failures of critical assets and implementation of condition-based maintenance programs as a substitute for run-to-failure or time-based applications. It is desirable, in the movement toward a modern electric power system, to develop improved sensor device technologies at sufficiently low cost to monitor asset health and performance in greater quantity with higher visibility. In regard to electrical parameter measurements, please refer to Novel Electrical Parameter Sensors—R&D thrusts.<sup>25</sup>

**Attributes:** Reliability, resiliency, security

**EGS level:** Component state, convergent network state

**Scope of activity:** Conduct sensor device technology development at laboratory scale, followed by pilot-scale deployment and testing and ultimately technology transition to industry.

### **Key Assets**

#### **Large Power Transformers**

Large power transformers (>~100 MVA) represent a major critical asset class for which failures can be catastrophic and costly. Sensor technologies currently exist; however, further advances can enable improved identification of transformer performance degradation—by dissolved gas analysis (DGA), internal temperature measurements, insulation oil level monitoring, and transformer bushing fault detection—prior to catastrophic failure. Lower-cost approaches would also enable more ubiquitous implementation.

**Key measurements:** Temperature, chemistry, moisture, oil level, fault currents, voltage, vibration, ambient temperature,

---

<sup>25</sup> Electrical parameter measurements can play a key role in asset monitoring. But detailed R&D thrusts related to all electrical parameter sensors are condensed in the Novel Transducers area (Appendix D4) to best leverage synergies with regard to electrical parameter sensing across the entire range of applications within the power system.

internal pressure, cumulative operating conditions (stresses over time), tilt/sag

#### **Distribution system equipment**

Distribution-level grid assets including power transformers, capacitor banks, switches, circuit breakers, distribution lines, and others have not been heavily instrumented from a health monitoring perspective because of the high cost and low value per asset or node. However, ubiquitous deployment of sensor technology at a sufficiently low cost per asset/node in the distribution system could yield significant improvements in overall system resilience and stability. A significant driver for monitoring is the increase in DERs, distribution interdependencies, and automation. Increased deployment of power electronic converters is also occurring for grid interconnection of DER. New sensors for asset health monitoring of these converters is therefore an area of emerging importance. In contrast to transmission assets, relatively limited historic data exist regarding what measurements are critical for detecting and preventing distribution asset failures. Sensor development efforts must be coupled with system-level models and targeted experimental R&D to understand how incipient failures can best be predicted.

**Key measurements:** Temperature, chemistry, moisture, oil level, fault currents, voltage, vibration, ambient temperature, internal pressure, cumulative operating conditions (stresses over time), cumulative switch/circuit breaker cycles, tilt/sag

#### **Substations**

Substations serve as interconnection points between multiple high-voltage transmission lines or between those lines and distribution systems. Substations will commonly employ a broad range of components, including transformers, circuit interrupters/breakers, voltage controlling equipment, and power factor correction devices (e.g., capacitors, reactors, static VAR compensators), power flow controllers, protection and control equipment (relays, fuses), voltage and current transformers, and other instrumentation. With increased renewable resource penetration and other DERs, regulation and protection devices are anticipated to experience increased demand and operational challenges. Increased deployment of power electronic converters is also anticipated. Substations play a critical role in the health of the modern electrical power system. Health monitoring schemes that are increasingly real-time rather than based upon periodically scheduled inspections can avoid catastrophic substation-related failures and enable proactive maintenance programs that minimize disruptions and the associated social and economic costs.

**Key measurement parameters:** Temperature, chemistry, oil level, fault currents, voltage, visual inspection, vibration, ambient temperature, internal pressure, cumulative operating conditions (stresses over time), cumulative switch/circuit breaker cycles

#### **Transmission Lines**

Sensors for transmission line monitoring can enable a utility to move further toward condition-based maintenance programs for these lines. While transmission line monitoring technologies exist, further cost reductions and novel technologies can enable broader deployment and/or higher fidelity information at a given cost to increase visibility within the transmission system.

**Key measurement parameters:** Tension, sag, temperature, visual inspection, proximity monitors, leakage currents

#### **Centralized Thermal Generators**

Increased cycling of centralized generators, as in fossil-based power plants, is required with increasing levels of renewable penetration in the electric grid. Cycling and load following can accelerate degradation of the materials and components within these plants. Also, this type of cycling can lead to reduced efficiencies, greater down time, higher costs of electricity due to increased need for time-based preventative maintenance procedures, and potentially even catastrophic failures. A need exists for new asset health monitoring of these generators to allow for early detection of potential failures within a power plant to enable condition-based maintenance and real-time processing adjustments to reduce potential impacts.

**Key measurement parameters:** Temperature, strain, vibration, delamination or spallation, acoustic—audible or ultrasonic

#### **DERs**

DER can also benefit from real-time asset health monitoring. Ubiquitous deployment of sensor technology at a sufficiently low cost per DER or node that is capable of health performance monitoring of these systems can yield significant improvements in overall system resilience and stability.

**Key measurement parameters:** Temperature, state of charge, fault currents, voltage

**Multi-tier metrics:** To address the needs for asset health monitoring across the modern electric power system infrastructure, a tiered set of metrics is required that captures (1) cost, (2) functional performance, and (3) geospatial characteristics. The latter is needed to identify requirements for sensing technologies that are able to measure parameters having spatial characteristics that are consistent with the grid

assets to be monitored. For example, T&D lines are best monitored by sensor technology platforms with linear characteristics, whereas substations or specific grid assets are more suitable for multipoint or areal imaging-based sensor platforms. The following table provides a summary of the various grades/levels of performance and examples of cost, performance, and geospatial characteristics needed across the

various research thrusts described below. In the table, the term “low grade” refers to lower-cost and potentially lower-performance solutions typically relevant for distribution level applications, “high grade” refers to higher-cost and higher-performance solutions typically relevant for transmission level or generator monitoring.

**Overall metrics for asset health monitoring sensors**

Grade	Type	Cost	Performance	Geospatial characteristics
<b>Low grade/distribution level</b>	Minimal costs to enable ubiquitous deployment	<ul style="list-style-type: none"> <li>Typical sensor cost metrics are &lt;\$100/node (deployed) and communication; &lt;\$1–10 is desired in most cases</li> </ul>	<p>Adequate, but potentially reduced performance compared with existing transmission-level sensors</p> <p>Proxy-based sensing through indirect parameters measurable through low-cost platforms</p> <p>Compatibility with deployment requirements such as (1) internal to grid assets, (2) medium-voltage distribution lines, and so on</p>	Single point— a sensor with a single node
<b>high grade/transmission level</b>	Dramatic cost reductions to increase deployment	<ul style="list-style-type: none"> <li>At least 10× cost reduction compared with existing commercial technologies is targeted.</li> <li>Typical metrics are &lt;\$1000/node deployed and with communication</li> </ul>	<p>Comparable or improved performance compared with existing state-of-the-art commercial sensors</p> <p>Compatibility with deployment requirements such as (1) internal to grid assets, (2) high-voltage transmission lines, and so on</p>	<p>Multipoint— a sensor with multiple discrete nodes</p> <p>Linear—a sensor with linear nodal sampling capability</p> <p>Areal— a sensor with areal nodal sampling capability</p>
<b>High grade/centralized thermal generator</b>	Costs are <b>not</b> the primary driver for technology development because of lack of existing technology	<ul style="list-style-type: none"> <li>Typical metrics are &lt;\$10,000/node deployed and communication; &lt;\$1000 desirable in some cases</li> </ul>	<p>New sensor device technology development and deployment</p> <p>Compatibility with operation in extremely high temperatures and harsh environmental conditions representative of fossil- and nuclear-based generation</p>	

**1: Real-Time Dissolved Gas Analysis Sensors**

Real-time DGA sensors can enable early fault detection and classification for electrical assets in which insulation oil is employed, including power transformers, underground transmission lines, and circuit breakers. Lower-cost DGA technologies, with the following characteristics, need to be developed for broader deployment to a larger range of grid assets.

*High-Grade/Transmission Level:*

Key measurements/metrics: Fully installed cost <\$1,000

Performance:

- H<sub>2</sub>, CH<sub>4</sub>, acetylene, moisture, CO, other hydrocarbons (levels ranging from 1 to 500 ppm),
- Same or better performance as current state-of-the-art commercial on-line DGAs

Geospatial: Single point

*Low-Grade/Distribution Level:*

Key measurements/metrics: Fully installed <\$100,

Performance:

- At least 1 proxy species (H<sub>2</sub>), preferably multiple species (H<sub>2</sub>, CH<sub>4</sub>, acetylene)
- H<sub>2</sub>, CH<sub>4</sub>, acetylene, moisture, CO, other hydrocarbons (levels ranging from 1 to 500 ppm)

Geospatial: Single point

**2: Grid Asset Internal Temperature**

Internal temperature is a key parameter which serves as an early indicator of fault conditions in essentially all electrical grid assets, including centralized thermal generators. Temperature measurements tend to provide insights into natural degradation and failures of electrical grid assets including aging, arcing, etc. Lower-cost temperature probes that can be deployed internal to electrical grid assets need to be developed including multi-point sensor technologies. High-temperature, harsh-environment sensor technologies also need to be developed for centralized thermal generator applications.

*High-Grade/Transmission Level:*

Cost: Fully installed cost <\$2,000

Performance:

- Temperature (ambient to ~100°C)

Geospatial: Multipoint, >10 individual nodes

*Low-Grade/Distribution Level:*

Cost: Fully installed cost <\$100

Performance:

- Temperature (ambient to ~150°C)

Geospatial: Single point

*High-Grade/Centralized Thermal Generator:*

Cost: Fully installed cost <\$10,000

Performance:

- Temperature (ambient to as high as 1500°C)

Geospatial: Multipoint, >10 individual nodes

**3: Grid Asset Internal Strain**

Internal strain is a parameter that correlates with other proxy measurements that serve as early indicators of fault conditions

in essentially all electrical grid assets, including centralized thermal generators. Lower-cost strain sensor probes that can be deployed within electrical grid assets need to be developed, including multipoint sensor technologies. High-temperature, harsh-environment sensor technologies also need to be developed for centralized thermal generator applications.

*High-Grade/Transmission Level:*

Cost: Fully installed <\$2,000

Performance:

- Strain (2 µε resolution, 100 µε range)

Geospatial: Multipoint, >10 individual nodes

*Low-Grade/Distribution Level:*

Cost: Fully installed <\$100

Performance:

- Strain (2 µε resolution, 100 µε range)

Geospatial: Single point

*High-Grade/Centralized Thermal Generator:*

Cost: Fully installed <\$10,000

Performance:

- Strain (2 µε resolution, 100 µε range)
- Ambient to temperatures greater than 600°C

Geospatial: Multipoint, >10 individual nodes

**4: Acoustic and Ultrasonic Vibration Event Detection**

Proxy measurements, such as vibration detection, can play an important role in the indirect identification of early signatures of events such as faults before catastrophic failure, without the need for intrusive sensors placed within electrical grid assets. Applications include detection of low-probability, high-consequence events that can lead to grid asset failures, including external impacts or attacks, loose junctions or failing connections, and arcing or other electrical failures. Depending upon the event/fault characteristics, vibrations can be detected and analyzed in the acoustic or ultrasonic range. If coupled with pattern recognition algorithms, signatures of particular events/faults can be extracted.

*High-Grade/Transmission Level*

Cost: Fully installed <\$1,000

Performance:

- Ultrasonic vibration (10 kHz to 1 MHz)
- Acceleration range ( ±20g)
- Sensitivity (10000 LSB/g)
- Acoustic vibration (20 Hz to 10 kHz)
- Signal-to-noise ratio ( >60 dB)
- Sensitivity (–50 dBFS)

Geospatial: Single point

*Low-Grade/Distribution Level*

Cost: Fully installed <\$100

Performance:

- Ultrasonic vibration (10 kHz to 1 MHz)
- Acceleration range ( ±5g)
- Sensitivity (1000 LSB/g)
- Acoustic vibration (20 Hz to 10 kHz)
- Signal-to-noise ratio ( >60 dB)
- Sensitivity (–50 dBFS)

Geospatial: Single point

*High-Grade/Centralized Thermal Generator:*

Cost: Fully installed <\$1,000

Performance:

- Ultrasonic vibration (10 kHz to 500 kHz)
- Acceleration range ( ±20g)
- Sensitivity (10000 LSB/g)
- Acoustic vibration (20 Hz to 10 kHz)
- Signal- to-noise ratio ( >60 dB)
- Sensitivity (–50 dBFS)

Geospatial: Single point

**5:Areal Temperature and Gas Insulation Leak Monitoring through Imaging**

Thermal imaging techniques can be extremely valuable for real-time areal monitoring of electrical grid assets for detecting local hotspots in cases where visual access is possible, such as in substations and near power transformers. However, the high cost of standard thermal imaging technologies prohibits widespread deployment. Lower-cost thermal imaging technologies need to be developed with sufficient areal range/resolution for broader classes of electrical grid assets.

Emerging imaging techniques can also enable real-time areal monitoring of leaks of insulation gases in gas-insulated substations, arcing on transmission lines or within their equipment, and so on. Early detection of insulation gas leaks is valuable because of the high global warming potential of standard insulation gases, such as SF<sub>6</sub>, combined with the potential for catastrophic failure if proper insulation levels are not maintained within the equipment. Low-cost imaging technologies are proposed with sufficient areal range/resolution for typical gas-insulated electrical grid assets.

*High-Grade/Transmission Level*

Cost: Fully installed <\$2,000

Performance:

- Temperature (ambient to ~125°C, resolution ~2°C)
- SF<sub>6</sub> concentration (levels above ~100 ppm in air)

Geospatial: Areal (range 300 ft<sup>2</sup>, resolution 0.06 ft<sup>2</sup>)

*Low-Grade/Distribution Level*

Cost: Fully installed <\$200

Performance:

- Temperature (ambient to ~125°C, resolution ~2°C)
- Geospatial: Areal (range – 300 ft<sup>2</sup>, resolution 0.06 ft<sup>2</sup>)

**6: Pole Tilt and Line Sag Monitoring**

Real-time monitoring of T&D line poles and line sag monitoring can provide unique insights into the origin of existing faults, as well as information about where such assets must be inspected to determine if maintenance, repair, or vegetation removal is needed. Low-cost sensing technologies, with capabilities for multi-axis tilt monitoring of lines, need to be developed for deployment at both the T&D levels.

*High-Grade/Transmission Level*

Cost: Fully installed <\$1,000

Performance:

- Angle of inclination relative to vertical (0–90° range, 2° resolution)
- Angle of twist relative to horizontal reference (0–360° range, 2° resolution)

Geospatial: Single point

*Low-Grade/Distribution Level*

Cost: Fully installed <\$50, preferably <\$5

Performance:

- Angle of inclination relative to vertical (0–90° range, 2° resolution)

Geospatial: Single point

**7: Line Temperature Profile**

Local line temperatures can provide information about faults and failures, as well as important information required for dynamic line rating on a broader range of transmission and even distribution line assets. Low-cost temperature sensor technologies need to be developed, with a particular emphasis on linear sensor technologies that enable full temperature profile characterization along the entire length of a line and with sufficient spatial resolution and measurement range.

*High-Grade/Transmission Level*

Cost: Fully installed <\$5,000 per km

Performance:

- Temperature (ambient to ~150°C)
- Geospatial: Linear
- Spatial resolution > 6 in.
  - Maximum interrogation distance > 10 km

#### *Low-Grade/Distribution Level*

Cost: Fully installed <\$1,000 per km

Performance:

- Temperature (ambient to ~150°C)

Geospatial: Linear

- Spatial resolution >1 in.
- Maximum interrogation distance >1 km

#### *High-Grade/Centralized Thermal Generator:*

Cost: Fully installed <\$10,000

Performance:

- Temperature (ambient to as high as ~1500°C)

Geospatial: Linear

- Spatial resolution >1cm
- Maximum interrogation distance >10 m

### **8: Line Acoustic Monitoring**

Adverse weather conditions, including wind and storm conditions, as well as existing faults can introduce acoustic signals that propagate along T&D lines. Spatially resolved acoustic monitoring techniques can enable identification of the locations of conditions or faults that can result in widespread outages if allowed to persist without intervention. Low-cost temperature sensor technologies need to be developed, with a particular emphasis on linear sensor technologies that enable local identification of the sources of measured acoustic signals for condition-based maintenance.

#### *High-Grade/Transmission Level*

Cost: Fully installed <\$5,000 per km

Performance:

- Acoustic profile (20 Hz to 10 kHz) (coupled with pattern recognition algorithms)
- Signal-to-noise ratio (>60 dB)

- Sensitivity (-35 dBFS)

Geospatial: Linear

- Spatial resolution >120 in.
- Maximum interrogation distance > 10 km

#### *Low-Grade/Distribution Level*

Cost: Fully installed <\$1,000 per km

Performance:

- Acoustic profile (20 Hz to 10 kHz) (coupled with pattern recognition algorithms)
- Signal-to-noise ratio (>60 dB)
- Sensitivity (-35 dBFS)

Geospatial: Linear

- Spatial resolution > 12 in.
- Maximum interrogation distance >1 km

#### *High-Grade/Centralized Thermal Generator:*

Cost: Fully installed <\$10,000

Performance:

- Temperature (ambient to as high as ~1500°C)
- Acoustic vibration (20 Hz to 10 kHz)
- Signal-to-noise ratio (>60 dB)
- Sensitivity (-50 dBFS)

Geospatial: Linear

- Spatial resolution >1 cm
- Maximum interrogation distance >10 m

### **#9: Energy Storage (Internal Chemistry)**

Energy storage is becoming an increasingly important electrical grid asset, yet catastrophic conditions can occur in cases when leaks or other failures of the electrodes, electrolytes, or sealing are encountered. Chemical signatures of such leaks and failures can be used for preventative maintenance as well as to prevent widespread electrical power disruption caused by energy

storage failure. Low-cost embedded chemical sensor technologies need to be developed with a particular emphasis on early detection of species that can signify onset failures, such in Li-ion batteries.

#### *Low-Grade/Distribution Level*

Cost: Fully installed <\$200

Performance:

- Presence of chemical species indicative of failure onset (HF at 50 ppm, others)

Geospatial: Single point

### **10: Boiler Water Chemistry Monitoring**

Existing plants are being required to cycle (on/off) and power ramp under conditions that were not envisioned when they were originally designed, built, and deployed. Boiler-water chemistry is one of the key parameters for these plants that can provide an early indication of corrosive conditions that must be prevented to avoid failures or unnecessary costly repairs. A key requirement involves the ability to monitor chemical parameters, such as the acid level (pH) of water chemistry, under high temperature and pressure conditions relevant for centralized thermal generator boiler applications. Therefore, real-time elevated pressure and temperature pH sensors need to be developed.

#### *High-Grade/Centralized Generator Level*

Cost: Fully installed <\$50,000

Performance:

- Real-time pH monitoring (pH range ~4–11)
- Temperatures (ambient to as high as 1000°C)

Geospatial: Single point

3. SENSING AND MEASUREMENT DEVICES | Grid Asset Health Performance Monitoring

DOE Lab Contact: Paul Ohodnicki (NETL)	Priority	Rank	FY2017	FY2018	FY2019	FY2020	FY2025	FY2030	Extended Grid State (EGS)						Attributes									
									Asset : Geospatial Information	Asset : Status	Asset : Type/Config	Asset : Condition	System : Structure	System : Markets	System : Electrical	System : Thermal	Ambient : Communications	Ambient : Weather	Reliable	Secure	Affordable	Flexible	Resilient	Sustainable
Grid Asset Internal Temperature	1	1																						
Real-Time Dissolved Gas Analysis Sensors	2	2																						
Pole Tilt and Line Sag Monitoring	2	3																						
Line Temperature Profile	2	4																						
Acoustic and Ultrasonic Vibration Event Detection	2	5																						
Boiler Water Chemistry Monitoring	3	6																						
Internal Chemistry (Energy Storage)	3	7																						
Line Acoustic Monitoring	4	8																						
Areal Temperature and Gas Insulation Leak Monitoring Through Imaging	4	9																						
Grid Asset Internal Strain	5	10																						

Research Timeline Legend:

-  early stage research @ TRL 1-3
-  software/hardware/other development & testing and begin interfacing with standards organizations, @ TRL 3-5
-  integration and testing @ TRL 5-7+
-  field validation and testing
-  working with organizations to refine interoperability standards

## Phasor Measurement Units for Grid State and Power Flow—R&D Thrusts

PMUs are a critical enabling technology for providing power system visibility and control capability. They have become more widely used to measure and time-stamp basic electrical parameters in modern systems since 2009, but they still require significant improvements in both performance and cost to achieve grid modernization goals related to system visibility and control. The cost-reduction and performance improvement goals described in the subtopics of this focus area are intended to catalyze wider and more rapid adoption of PMUs across the grid and to enable novel dynamic control implementations that significantly enhance observability, control and reliability.

**Key measurements:** Voltage, current, frequency, phase angle, real and reactive power

### **1: Improve the Dynamic Response and Accuracy of PMUs**

Improve the dynamic response of PMU technologies to significantly improve dynamic grid state measurements and enable high-speed, real-time control applications (including automatic controls). This R&D thrust seeks to provide a 1 to 2 order of magnitude performance improvement over the current PMU state of the art.

Improvements in synchrophasor precision are also needed. In particular, phase angle differences in distribution systems are much smaller than in transmission systems. Thus synchrophasor angle measurements are not adequate with current PMU technology. As a result, there is a need to develop PMUs that can accurately capture small differences in phase angles within distribution systems, especially on the same distribution feeder. A large percentage of these angle differences on the same feeder could be less than 0.01 degree between adjacent feeder locations (nodes). Differences this small cannot be appropriately captured with current commercially available PMUs. In addition, low measurement data rates (60 or 30 frames per second or fps) and long estimation windows (5~6 cycles) limit the application of PMUs in some critical grid protection and control applications.

**Key measurements:** Voltage and current phasors (magnitudes and angles)

#### **Key metrics:**

Target specification: <1 cycle time delay  
Measurement rate: > 480 fps  
Angle resolution: <0.001 to 0.002 degrees  
TVE: <1%

**Attributes:** Resiliency, flexibility

**EGS level:** Electrical state

**Scope of activity:** Develop robust, cost-effective PMU technology and phasor calculation algorithms with improved resolution, precision, and dynamic response with pilot-scale deployment and testing.

### **2: Lower the Cost of PMUs**

Lower the cost of PMUs to enable greater wide-area deployment and use in both T&D systems and provide more granular grid visibility and event detection. This effort can also include multiple product implementations, including substation use, transmission line monitoring, and integration with existing assets and original equipment manufacturer power equipment.

**Key measurements:** Unit cost, installation cost, operating and maintenance costs

#### **Key metrics:**

Unit cost <\$500 (transmission system) and <\$100 (distribution system)

Installation cost <\$1,000 (transmission system) and <\$100 (distribution system)

Operating and maintenance costs TBD (requires analysis)

**Attributes:** All

**EGS level:** Electrical state

**Scope of activity:** Seek to develop prototypes and system architectures that reduce total installed PMU costs, including unit cost, installation, communication-associated costs, and cyber-physical security-associated costs.

### **3: Improve PMU Timing Reliability**

Incorporate alternative, high-reliability timing methods into PMU architectures to reduce or eliminate current dependence on GPS timing signals. The lack of an alternative timing source to GPS has implications for both reliability (current high dependence on GPS operational availability) and cyber-physical security (spoofing vulnerability of GPS signals).

**Key measurements:** PMU timing, system reliability

#### **Key metrics:**

Timing: Short term—IEEE C37.118.1-2011 timing error compliance

Reliability: 99.999999% timing service reliability

**Attributes :** Resiliency, flexibility

**EGS level:** Electrical state

**Scope of activity:** System hardware and algorithm design development with prototype demonstration in pilot-scale environment

### **4: Understand and Improve Real Grid Environment Measurement Performance**

Currently the accuracy of PMUs is evaluated using synthetic signals generated in a laboratory instead of using real electrical signals. The real electrical signals in the grid are more complex owing to constant disturbances, interferences, noise, and so on. Thus, the measurement accuracy of PMUs in the actual power grid environment is not well understood, particularly for distributed measurements where the measurement environment is more complex. In addition, the lack of real measurement evaluation makes it difficult to verify PMU data across different manufacturers. This research area seeks to understand the characteristics of actual grid signals captured by PMUs in the field and the effect of the actual system on the accuracy of synchrophasor measurements.

**Key measurements:** Characteristics of real power grid signals

**Key metrics:** Noise (signal-to-noise ratio and noise color), disturbance, interferences level

**Attributes:** Resiliency, flexibility

**EGS level:** Electrical state

**Scope of activity:** Analyze and characterize real electric grid signals and evaluate their impact on synchrophasor measurement accuracy

**4. SENSING AND MEASUREMENT DEVICES** | Phasor Measurement Units for Grid State and Power Flow

DOE Lab Contact: Yarom Polsky(ORNL)	Priority	Rank	FY2017	FY2018	FY2019	FY2020	FY2025	FY2030	Asset: Geospatial Information	Asset: Status	Asset: Type/Config	Asset: Condition	System: Structure	System: Markets	System: Electrical	System: Thermal	Ambient: Communications	Ambient: Weather	Reliable	Secure	Affordable	Flexible	Resilient	Sustainable	
									EGS	Attributes															
Lower the cost of PMUs	2	1																							
Understand and improve real grid environment measurement performance	2	2																							
Improve PMU timing reliability	3	3																							
Improve the dynamic response and accuracy of PMUs	3	4																							

**Research Timeline Legend:**

- early stage research @ TRL 1-3
- software/hardware/other development & testing and begin interfacing with standards organizations, @ TRL 3-5
- integration and testing @ TRL 5-7+
- field validation and testing
- working with organizations to refine interoperability standards

## Novel Electrical Parameter Sensors—R&D Thrusts

With the transition to modern power systems, there is a heightened need for electrical parameter reporting at faster rates, higher precision, and greater accuracy—all while reducing the costs associated with this information. However, oftentimes, cost reduction is an orthogonal to more accurate or precise measurement functionality. Novel electrical transducers can play an impact across a broad range of applications and use

cases across the transmission and distribution system. To explore synergies and cross-cutting opportunities, the development and application of novel voltage and current transducer was the focus for achieving (1) dynamic system protection, (2) grid asset functional performance monitoring, and (3) advanced generation controls. Current proposed research thrusts within these focus areas were developed with a

clear understanding of the current industrial state of the art and quantitative metrics for new sensing and measurement technology development. The following table provides a summary of the various grades/levels of performance and examples of cost, metrics, and other characteristics identified across the various novel sensor R&D thrusts that follow.

**Metrics for novel electrical parameter sensors**

Grade	Type	Cost	Performance	Other characteristics
Low grade/distribution level or customer-sited		Minimized costs to enable ubiquitous deployment	Adequate but potentially reduced performance compared with existing transmission-level sensors.	Further cost reductions may be achieved via multiple sensors sharing the same communication infrastructure.
		Typical metrics are <\$100/node deployed and communications; <\$5–10 is desired in some cases.	Proxy-based sensing through indirect parameters measurable through low-cost platforms.	
High grade/transmission level		Dramatic cost reductions to increase deployment.	Compatibility with deployment requirements such as (1) internal to grid assets, (2) medium-voltage distribution lines, and others.	
		At least a 10× reduction in costs compared with existing commercial technologies is targeted.	Comparable or improved performance compared with existing state-of-the-art commercial sensors.	
		Typical metrics are <\$2000/node deployed and with communication.	Compatibility with deployment requirements such as (1) internal to grid assets, (2) high-voltage transmission lines, and others.	

Advancements in printed sensors and wireless interrogation of passive sensors indicate that a suite of novel transducers capable of being deployed/installed directly onto electrical grid assets is coming closer to commercial viability. The following is a list of several novel sensor R&D thrusts identified as future needs of the electric grid.

### 1: Fast-Acting Sensors for Fault Detection and Dynamic System Protection

In a modern power system, fast-acting sensors must detect electrical abnormalities in a variety of locations. These locations range from behind-the-meter at customer locations to bulk power transfer infrastructure and everywhere in between. With the transition to a modern power system, the grid is becoming more highly networked to enable two-way power on its electrical lines. Coupling two-way power flow and the

increase in the number and diversity of grid assets creates a greater challenge to protect grid assets from disruptions such as power surges, over and under frequency, over and under voltages, and harmonics. Fast-acting sensors are needed on the grid to identify emerging and immediate problems and to prevent damage to grid assets by deploying adaptable protection schemes. Following detection of an abnormality, these sensors also must initiate a broadcast signal or control response to protect grid assets from damage. These sensors must quickly transmit their data, so that relays and switches can be activated to protect grid equipment from damage. Sensors must be capable of high detection performance (e.g., response time, accuracy, precision) to meet the requirements of adaptive protection schemes.

Fault current detection can play a key role in the detection of fault conditions, potentially including rapid transient fault currents that can indicate human-caused or natural threats including cyber-physical attacks, electromagnetic pulses, and geomagnetic disturbances. Rapid, high-bandwidth fault-current sensors are proposed, as well as low-cost sensors for ubiquitous deployment.

Much like fault current detection, under and overvoltage monitoring of electrical grid assets (including transient overvoltages), which is an indirect measurement of fault current, can play an important role in the detection of fault conditions. Rapid, high-bandwidth under and overvoltage sensors are proposed, as well as low-cost sensors for ubiquitous deployment.

Real-time sensors are needed on the grid to identify emerging and immediate problems and to prevent damage to grid assets by deploying adaptable protection schemes. These sensors must quickly sense and transmit their data, so that relays and switches can be activated to protect grid equipment from damage.

*Current metrics: High-Grade/Transmission Level*

Fault currents (0.01 nominal rated current to 100× nominal rated current)

Bandwidth (line frequency to greater than 10 MHz)

Latency (<1 millisecond)

Fully installed cost <\$2,000

*Current metrics: Low-Grade/Distribution Level*

Fault currents (0.1 nominal rated current to 5× nominal rated current)

Bandwidth (line frequency to greater than 1 MHz)

Latency (<5 milliseconds)

Fully installed cost <\$300

*Voltage metrics: High-Grade/Transmission Level*

Voltage (0.01× up to 5× nominal voltage per unit (p.u.))

Time resolution of voltage change (<1 microsecond)

Latency (<1 millisecond)

Total installed cost <\$2,000

*Voltage metrics: Low-Grade/Distribution Level*

Voltage (0.1× up to 2× nominal voltage, p.u.)

Time resolution of voltage change (<10 microseconds)

Latency (<5 milliseconds)

Total installed cost <\$300

*Frequency :*

Frequency measurement accuracy <0.5 milliradians

*Phase angle:*

Phase angle accuracy within ( $\pm 0.5^\circ \times$  harmonic number)

*Harmonic composition:*

Individual harmonic amplitudes (accuracy <5%)

Individual harmonic phase angles (accuracy <1%)

Sampling rate (>1000 per 60 Hz cycle)

Total harmonic distortion (accuracy <0.5%)

*Cost:*

Total installed cost depends on the application, but <\$2,000

**2: Grid Asset Health Performance Monitoring (Traditional Transformers)**

Asset monitoring for determining equipment health condition can be applied to a variety of assets, including generation, energy storage, and loads, as well as the electrical components of the power system.

A number of benefits can be derived from improved visibility of the condition and health of grid assets, including increased reliability and resilience through prevention of catastrophic failures of critical assets and implementation of condition-based maintenance programs as a substitute for run-to-failure or time-based application requirements of the T&D system.

Traditionally, expensive components such as transformers were monitored for health condition; while other components, such as distribution transformers, operated until failure and were replaced with spares. With the movement toward a modern power system, it is desirable to monitor the health and performance of grid assets in greater numbers—which could be achieved by reducing the cost of asset monitoring sensors.

**Key measurements:**

Voltage, currents, real and reactive power, phase angle, harmonics, and THD

**Key metrics:**

Voltage and current monitoring:  
Voltage (up to 5× nominal voltage),

Current (up to 3× nominal voltage)

Time resolution (<1 microsecond)

Sampling rate (>1000 per 60 Hz cycle)

Latency (<1 millisecond)

State of magnetization of the core:

State of magnetization as function of operating conditions.

Magnitude and distribution of main, leakage and zero sequence flux:

Flux as function of operating conditions.

Total losses and localized loss densities in windings and different structural parts of the transformers:

Losses as function of operating conditions.

**3: Performance Sensors for Next Generation Devices**

Next-generation devices include power conversion devices (solid-state transformers, energy storage, and DER). Next-generation transformers will require sensors that do not rely predominantly on gas sensing. A greater market share of transformer-less power electronics will be used for bulk power transfer. Examples of such transformer-less power electronics are devices such as FACTS, STATCOMs, UPCS, and similar ones. These devices are based on solid-state switching devices and require fundamentally different monitoring approaches.

Rapid penetration of DER resources, including conventional and renewable generation, call for increasing installations of energy storage (ES) for multiple applications and benefits (such as providing power from renewables when the source is momentarily unavailable—e.g., solar PV when clouds block the sun). Accurate and timely information is needed for electrochemical states of the ES for both controls and, even more important, safety status.

**Key measurements for power conversion elements:** Current, voltage, current derivative, voltage derivative, frequency content, phase angle, fault currents

**Key metrics:**

Voltage, currents, real and reactive power, phase angle, harmonics, and THD, pulse width modulation (PWM) diagnostics info

Voltage and current monitoring: (same as for "traditional" transformers)

Voltage (up to 5× nominal voltage),

Current (up to 3× nominal voltage)

Phase balance/imbalance (accuracy <0.5%)

PWM— accuracy and balance (accuracy <0.5%)

Time resolution (<1 microsecond)

Sampling rate (>1000 per 60 Hz cycle)

Latency (<1 millisecond)

Phase angle accuracy ( $\pm 0.5^\circ \times$  harmonic number)

Harmonics composition:

Individual harmonic amplitudes (accuracy <5%)

Individual harmonic phase angles (accuracy <1%)

Sampling rate (>1000 per 60 Hz cycle)

THD (accuracy <0.5%)

Latency (<1 ms)

Sampling rate (>100 per 60 Hz cycle)

Cost (<\$10 per generator)

**Key measurements for energy storage:** State of charge/discharge, rate of charge/discharge, depth of charge/discharge (per cycle, and average over life), pressure, outgassing state/status, cumulative number of cycles (life), cumulative charge/discharge information (lifetime kWh/MWh), temperature (to avoid temperature run-off)

**Key metrics:**

Normalized state of charge/discharge, 0–100% (accuracy <1%)

Latency (<1 millisecond)

Rate of charge/discharge, % (accuracy <1%)

Latency (<1 millisecond)

Depth of charge/discharge, % (per cycle, and average over life)

Reporting frequency = no less than once/day

Cumulative number of cycles (life), (accuracy = number of cycles)

Reporting frequency = no less than once/day

Cumulative charge/discharge information (lifetime kW/h/MW/h),

Reporting frequency = no less than once/day

**Key measurements of DER:** Smart functions enabled (e.g., volt-var control), voltage, current, frequency, phase angle, power flow, line losses, line loading, line/segment impedance

Voltage and current monitoring: (same as for "traditional" transformers)

Voltage (up to 5× nominal voltage),

Current (up to 3× nominal voltage)

Phase balance/imbalance (accuracy <0.5%)

PWM—accuracy and balance (accuracy <0.5%)

Time resolution (<1 microsecond)

Sampling rate (>1000 per 60 Hz cycle)

Latency (<1 millisecond)

Phase angle accuracy within ( $\pm 0.5^\circ \times$  harmonic number)

**Drivers:** Reliability, flexibility, resiliency, sustainability

**4: Derivative Sensors**

Similar to rate of change of frequency (ROCOF), derivative sensors for voltage and current may be very useful for utilities for monitoring of dynamic operating states. Applications and drivers of this thrust are fast detection and response to an event that is much faster than line (60 Hz) frequency. Applications can range from steady-state power flow and state estimation to detection of fast transient events.

**Key measurement parameters:** Current derivative, voltage derivative, frequency content, phase angle, fault currents, cost, ease of installation and maintenance, safety.

**Key metrics:**

Change in current with time (dI/dt):

Accuracy: Depends on ampacity rating of monitored application, between 0.1A/ms and up to 10A/ms

Bandwidth: 1 kHz–1 MHz

Latency (<1 ms)

Total installed cost <\$2,000

Change in voltage with time (dV/dt):

Accuracy: Depends on monitored application; better than %/ms or % p.u./ms

Bandwidth: 1 kHz–1Hz

Latency (<1 ms)

Total installed cost < \$2,000

ROCOF, or df/dt, for fundamental and (optionally) for harmonics

Accuracy: <0.05Hz/s

Bandwidth: 1 kHz–1 MHz

Latency (<1 millisecond)

Total installed cost < \$2,000

**5: Broadband Frequency-Selective Current Sensor**

Present current-monitoring and current-sensing technologies do not distinguish between frequencies contributing to current. Frequency-selective current sensing and monitoring would be very useful for monitoring harmonic contribution to current, as well as monitoring of transient dynamics.

**Key measurement parameters:** Current, frequency content, phase angle, fault currents

**Key metrics:** Accuracy, dynamic range, rate of sampling, latency, cost, ease of installation and maintenance, safety

Voltage and current sensing:  
Voltage (up to 5× nominal voltage),

Current (up to 3× nominal voltage)

Sampling rate (>1M samples per 60 Hz cycle)

Latency (<1 millisecond)

Phase angle accuracy within ( $\pm 0.5^\circ \times$  harmonic number)

Frequency metrics:  
Frequency resolution (better than 1 kHz)

Frequency bandwidth/selectivity (better than 10 kHz)

Cost (<\$10 per sensor)

**Drivers:** Resiliency, flexibility

**EGS level:** Electrical state

**Scope of activity:** Sensor technology development at laboratory scale, followed by pilot-scale deployment and testing, ultimately technology transition to industry

#### 6: Maturation of All-Optical Transducer Technologies

All-optical transducers use electro-optic or magneto-optic effects to sense the voltage or current signals. Some of their excellent properties include complete electrical isolation, small size/lightweight, and DC measurement capability. However,

technology maturation is needed to address the issues of cost effectiveness, resistance to temperature change and vibration, safety, and long-term stability.

In addition, integrating wireless communication and embedded data analysis functions onto the transducers needs consideration and R&D.

**Key measurement parameters:** Voltage, current, smart functions enabled (volt-var, etc.), voltage, current, frequency, harmonics and THD, phase angle, power flow, line losses, line loading, line/segment impedance.

**Key metrics:** Key metrics required for this functionality are listed in research thrusts mentioned above. However, for this thrust, the same metrics need to be reproduced using all-optical technologies. Accuracy, dynamic range, cost (<\$\$\$/kVA), ease of installation and maintenance, safety.

**Attributes:** Resiliency, flexibility

**EGS level:** Electrical state

**Scope of activity:** Optimization to address costs, temperature and vibration resistance issues, development of testing/calibration procedures, ultimately technology transition to industry for large-scale deployment

#### 7: Behind the Customer Meter Sensing

The focus is on transducers creating actionable information

from all the new smart devices that may be installed behind the customer meter location.

**Gap:** Lack of knowledge and detection of new installations behind the meter that are occurring without utility knowledge. Such devices and installations may be leading to bidirectional power flow without utility knowledge. Additionally, these devices and installations may be injecting additional harmonics or frequency noise onto the distribution system, which in turn may lead to reductions in the lifetimes of other utility assets (such as secondary transformers).

Additionally, a “watchman” application may be needed for a utility to verify that, for example, a behind-the-meter customer’s inverter is generating watt/Var as per an interconnection agreement.

**Key metrics:** Key metrics required for this functionality are listed in the research thrusts mentioned above. Some of the sensing solutions needed may already exist. What is definitely missing is system integration of the sensors.

**Potential solution:** A possible solution may be a device similar to a microinverter, which monitors the performance of several devices and broadcasts this information to the utility. A possible smart outlet that can collect power and power quality information is another example. A complete solution would be a smart meter, which not only provides revenue information but also provides power and power quality information for all devices at the customer’s interconnection location.

5. SENSING AND MEASUREMENT DEVICES | Novel Electrical Parameter Transducers

DOE Lab Contact: Olga Lavrova (SNL)	Priority	Rank	FY2017	FY2018	FY2019	FY2020	FY2025	FY2030	Asset: Geospatial Information	Asset: Status	Asset: Type/Config	System: Condition	System: Structure	System: Markets	System: Electrical	System: Thermal	Ambient: Communications	Ambient: Weather	Reliable	Secure	Affordable	Flexible	Resilient	Sustainable
Fast-Acting Current Sensors for Fault Detection and Dynamic System Protection	1	1																						
Broadband Frequency-Selective Current Sensor	2	2																						
Derivative Sensors	3	3																						
Maturation of all-optical transducer technologies	3	4																						
Grid Asset Health Performance Monitoring (Traditional Generation)	4	5																						
Performance Sensors for Next Generation Power Conversion Devices	4	6																						
Behind the meter (customer) sensing	5	7																						

Research Timeline Legend:

- early stage research @ TRL 1-3
- software/hardware/other development & testing and begin interfacing with standards organizations, @ TRL 3-5
- integration and testing @ TRL 5-7+
- field validation and testing
- working with organizations to refine interoperability standards

## End-Use/Buildings Monitoring—R&D Thrusts

Smart meters provide utilities with the ability to monitor energy consumption at end-use loads and enable monitoring of the distribution system for steady-state operation. However, the monitoring of a high penetration of DERs like energy storage and renewable generation located in the distribution system requires much faster and higher resolution (e.g., milliseconds) sensors for control, understanding system dynamics, and performing islanding and resynchronization of microgrids/nano-grids. These sensors should be able to provide the data needed for advanced applications, such as seamless islanding and resynchronization, transactive controls, and so on.

As various DER and energy storage technologies advance and become more affordable, customers will have the ability to control their energy production and consumption and become active participants in the distribution network. To enable optimal building operation, interactive and intelligent multi-component integrated sensors need to be developed for comprehensive self-learned/adaptive controls.

**Key measurements:** Frequency, phase angle, currents, voltage, real and reactive power, power factor, power quality, humidity, air quality, luminance, air flow, refrigeration liquid, occupancy.

### **1: Development of High-Resolution Building-to-Grid Sensors**

With the high penetration of DER and electricity energy storage at the end use, much faster and higher-resolution (e.g., millisecond) sensors (e.g., current/voltage or micro-PMU) are needed for control, system dynamics and possible home/building islanding operation as well as resynchronization. The measurement accuracy of sensors in the real measurement environment needs to be understood. The measurement consistency of sensors between different manufacturers in these real measurement environments needs to be quantified.

**Key measurement:** Frequency, phase angle, currents, voltage, real and reactive power, power factor, power quality

**Key metrics:**  
Current and voltage:

- Voltage (up to 2× nominal voltage),
- Current (up to 2× nominal current)
- Measured data resolution (milliseconds level)
- Measurement accuracy (error < 0.5%)
- Fully installed cost (<\$500)

Frequency, phase angle, real and reactive power, power factor, power quality:

- Calculated based on the current and voltage measurement
- Measured data resolution (milliseconds level for frequency and phase angle, seconds level for real and reactive power, power factor and power quality)
- Measurement accuracy (error < 0.5%)

**Drivers:** Reliability, resiliency, security, efficiency

**EGS level:** Component state

### **2: Development of High-Accuracy and Low-Cost Building Efficiency Sensors**

Currently, temperature, humidity, luminance, air quality, pressure, air flow, refrigeration liquid, and building occupancy are measured separately by corresponding sensors, which are high in cost and power consumption and low in accuracy. In addition, they don't communicate/share data. Future multi-sensor integrated measurement devices that are self-powered, integrated, interactive, and intelligent need to be developed for adaptive controls.

**Key measurements:** Temperature, humidity, air quality, luminance, air flow, refrigeration liquid, occupancy

**Key metrics:**

Temperature:

- Measurement data resolution (0.1°F)
- Accuracy (error <1°F)
- Fully installed cost (<\$10/node)

Humidity:

- Measurement data resolution (<0.5%)
- Accuracy (error <2 %)
- Fully installed cost (<\$10/node)

Luminance:

- Measurement data resolution (accurately report light levels for the building type to enable dimming between 30 and 70% of full to no light level for the space)
- Fully installed cost (<\$10/node)

Air quality, Air flow:

- Accuracy (error <5 %)
- Fully installed cost (<\$25/node)

Occupancy:

- Measurement data requirement (binary level for discrete control of lighting loads, zone-level occupancy with >90% accuracy to control ventilation based on occupancy)
- Accuracy (error <10 %)
- Fully installed cost (<\$50/ heating, ventilation, and air-conditioning zone)

Self-powered:

Battery size (enable mean time between charges of >72 hours)

### **3: Development of Intelligent Functions for Integrated Multi-Sensors**

Electricity use, temperature, luminance, air quality, building occupancy, and so on are measured by different pieces of equipment and typically are not correlated to perform advanced functions like FDD of building equipment. Future multi-sensor integrated measurement devices that are self-powered, interactive, and intelligent need to be developed for comprehensive self-learned/adaptive controls.

**Key measurement:** Frequency, phase angle, current, voltage, power factor, power quality, temperature, humidity, air quality, luminance, air flow, refrigeration liquid, occupancy

**Key metrics:**

*Same as for Research Thrusts 1 and 2*

Adaptive controls for transactive energy:

- Energy cost savings (>10%)
- Fully installed costs (<\$200)

Self-learning for load management:

- Energy cost saving (>10%)
- Fully installed costs (< \$200)

6. SENSING AND MEASUREMENT DEVICES | End-Use / Buildings Monitoring

DOE Lab Contact: Guodong Liu(ORNL)	Priority	Rank	FY2017	FY2018	FY2019	FY2020	FY2025	FY2030	EGS		Attributes									
Development of Intelligent Functions for Integrated Multi-sensors	1	1																		
Development of High-resolution Building-to-Grid Sensors	2	2																		
Development of High Accuracy and Low-Cost Building Efficiency Sensors	3	3																		

Research Timeline Legend:

- early stage research @ TRL 1-3
- software/hardware/other development & testing and begin interfacing with standards organizations, @ TRL 3-5
- integration and testing @ TRL 5-7+
- field validation and testing
- working with organizations to refine interoperability standards



## Weather Monitoring and Forecasting—R&D Thrusts

This focus area includes high-priority research thrusts for weather sensing devices with quantitative metrics where appropriate. The first R&D thrust deals with upcoming innovative and low-cost technologies that need significant R&D for successful integration. The second R&D thrust deals with the requirement of newer devices for advancing the state of the art. There are additional research thrusts related to utilization of weather data for advanced modeling, which appear under the data-driven grid modeling or analytics area.

Weather monitoring and forecasting is relevant to both electricity consumption and renewable (wind and solar) power generation. Increasing penetrations of weather-dependent renewable energy sources are making weather sensors even more important for monitoring and predicting DER generation. Installed capacities of solar photovoltaic (PV), concentrating solar power, and wind energy have grown significantly in recent years, so that they have a significant impact on generation profiles. Grid integration of these renewable energy systems now and in the future benefits from the operational awareness provided by real-time sensing of both wind and solar resources and energy production, as well as forecasting from weather prediction over time scales from 0–5 minutes to 24–48 hours ahead.

Additionally, weather or ambient conditions monitoring is important for forecasting consumption, accurately modeling loads, and forecasting the states of interdependent infrastructures such as transportation and water and gas systems for a resilient economy. Electricity consumption is closely tied to the weather, as heating and cooling can be major components of electricity demand. Temperature and humidity are key considerations in load forecasts and usage. Additionally, the transfer capacity of transmission lines depends on temperature.

**Key measurement parameters:** Wind speed, wind direction, temperature, humidity, soil moisture, water turbulence (offshore wind), irradiance (global horizontal irradiance or GHI, direct normal irradiance or DNI, and diffuse irradiance), spectral components, cloud motion, barometric pressure, precipitation, lightning, icing, renewable power generation

**EGS levels:** Topological state, component state, building state, ambient state, convergent networks

## **1 Integration and Testing of Innovative Low-Cost Weather Sensing Technologies**

There is a dearth of weather sensing technologies deployed at spatial resolutions sufficient for grid modernization. Thus, challenges exist related to adequate characterization of spatially resolved renewable resources and building loads. For wind, there is inadequate sampling of the lower atmosphere required for weather models to forecast many of the atmospheric phenomena that affect wind power production. For solar, there are not enough high-quality, low-cost sensors available for verification, observability, initialization, and development of irradiance and power forecast models. Thus, integrating and testing of innovative and low-cost weather sensors is a high-priority research thrust that requires considerable R&D.

Upcoming innovative applications such as lidar-based sensing, unmanned aerial vehicles (UAVs), all-sky cameras, PV-integrated reference cells, narrow band photodiodes, and LEDs need extensive research for their integration, calibration, and customization for each geographic location. For example, the Arable Mark device is a low-cost multi-parameter sensing device based on the LED principle. It has a unique suite of sensors to measure the downwelling and upwelling shortwave solar resource, longwave radiation, humidity, air temperature, and ground temperature. It is also equipped with seven downward- and upward-facing narrow-band spectrometer channels that measure spectral radiation and surface spectral reflectance. Although it is currently used for agricultural applications, much research is needed to investigate its usability and adaptability for grid use cases. Another sensor is the low-cost scalable security camera. Some of these devices can be integrated with robust communication and time synchronization capabilities that are relevant for enhancing grid observability.

The evaluation of weather sensors for the modern grid requires continuous collaboration among various stakeholders to create awareness and devise low-cost pathways to integrate these technologies.

## **Key metrics:**

<b>Parameters</b>	<b>Key metrics for innovative technologies</b>
Broadband irradiance components: GHI, DNI, diffuse horizontal irradiance (DHI), plane of array (POA), albedo	Photodiodes, reference cells (<\$300 cost, lifespan as long as the distributed panels), shadow band devices (at least 50% cost reduction from current ~\$14K, increased lifespan of shadow band motors for high-frequency measurements)
Spectral components, surface albedo, aerosol, moisture	Arable pulsepod (<\$600)
Clear sky index, cloud characterization, cloud base and top heights	Sky imagers and security cameras (<\$100), satellite sensing (low latency <1 min real-time data), lidar-based cloud height estimation (50% reduction in the current costs of ~\$24K)
Wind profile	Scalable radar and sodar based technology deployments for high-fidelity profiling (cost reduction from current 915 MHz (~\$600K) and 449 MHz (~\$300K))

**Attributes:** Enabling scalability for grid futures with high penetration of DER; improved energy forecasting, solar observability, and grid situational awareness; probabilistic uncertainty characterization of variable renewable generation and its ramps

**Scope of activity:** (1) Private-public partnerships for integration, comprising innovative sensing vendors, robust communication and data logger entities, national labs, academia, and utilities/independent system operators (ISOs). Prototype validation of low-cost camera integration and calibration for various grid edge locations.

## 2 Development of Devices for Enhanced Weather Observability

Weather phenomena are governed by fundamental physics. Models help to simulate and understand their evolution.

Weather sensors, apart from providing real-time measurements, also help in initializing and validating these physics-based models. Unlike the installation of other in situ sensors, weather sensing technologies face highly versatile conditions and variations due to the uncertainties in geographical location, elevation, and local (microscale) and mesoscale weather phenomena. There is a constant need to capture higher spatial and temporal resolution information for application-dependent parameters to improve forecasting and grid-edge resource observability. Advanced sensors coupled with accurate calibration capabilities could enhance the dynamism and observation accuracy under various conditions and could improve model initialization and reduce prediction uncertainties. For example, sensors or a combination of these sensors with multi-parameter sensing capabilities are needed to improve forecasts of clouds and therefore of surface irradiance. Getting the irradiance components right (GHI, DHI, DNI, and POA) is key to integrating higher shares of solar PV resources. Consequently, estimating the soil moisture accurately is critical for forecasting the development, evolution, and dissipation of clouds. Additionally, soil moisture information provides insights into the probability of flood conditions. Also, various instruments measuring solar radiation are not adequately maintained (e.g., kept clear from tree

branches or other shading, cleaned, calibrated, or maintained). Therefore, alternate capabilities are required to provide redundant measurements.

### Key devices and target metrics:

1. Sensors to measure surface albedo and spectral solar components more accurately in different terrains, that are synchronized with multiple parameters relevant for PV production and plant operational status (e.g., snow detection, hot spots, panel temperature, undesirable shading). Some examples include multiple narrow-band LEDs (~\$10 per installation) and filtered photodiodes.
2. Sensors to accurately measure precipitation and soil moisture to improve prediction of clouds and potential for flood events. Conventional microwave-based active sensing technologies are expensive, and satellite-based sensing has lower temporal resolution for this application. Innovative technologies like passive sensing using ultra-high frequency radio frequency identification devices promise lower cost solutions.
3. A new detector for the Absolute Cavity Radiometer for use as a primary instrument for calibrating devices measuring solar radiation. There are no instruments currently available in the market, as high-accuracy detectors were previously hand manufactured. A new commercially viable design needs to be developed. This detector requires an accuracy of 0.3% or better.

4. Portable calibrating devices for distributed and remote applications. Current calibrations are undertaken only in laboratories, and there is a need for a portable calibration device that is capable of onsite calibration and is traceable to a world reference.

5. Calibration capabilities for digital radiometers need to be developed, as current capabilities can handle only analog devices. This will enable localized and in situ calibration instead of a time-consuming and expensive calibration process available only at manufacturers' facilities.

**Attributes:** Improving energy forecasting, scalable deployment of sensors for smart grid, grid edge observability, measurement reliability, high-fidelity characterization of solar spectrum at different locations, calibration standard, low latency (<1 min for post-event contingency reserves, <5–15 min. for regulation reserves and ramping products)

**Scope of activity:** (1) Public-private partnerships to create and integrate these sensing technologies. (2) Impact and value proposition study to understand the spatial and temporal resolution needs from weather sensors for advanced grid modernization use cases. (3) Development of portable, low-cost, innovative measurement and calibration technologies working with sensor manufacturers. (4) Working with research laboratories to develop high-accuracy primary calibration devices.

7. SENSING AND MEASUREMENT DEVICES | Sensors for Weather Monitoring and Forecasting

DOE Lab Contact: Venkat Krishnan (NREL)



Research Timeline Legend:

-  early stage research @ TRL 1-3
-  software/hardware/other development & testing and begin interfacing with standards organizations, @ TRL 3-5
-  integration and testing @ TRL 5-7+
-  field validation and testing
-  working with organizations to refine interoperability standards

## COMMUNICATIONS

### Distributed Communications—R&D Thrusts

Distributed communication is viewed as a promising solution to tackle the challenges from large-scale deployment of distributed sensors in the future grid. This focus area targets an architecture design for distributed communication and an analysis of its impact on the operation and control of the electric power grid in terms of various applications.

The Distributed Architecture working group has gathered a variety of communication architectures that vendors are proposing—or have sold—to electric utilities specifically and energy delivery system end users in general. While many such architectures are being promoted, there are three key fundamental underpinnings to a next-generation grid-centric distributed communication architecture that need to be addressed: IIoT/IoT, wireless spectrum congestion management, and cyber-physical security.

In addition, the utility's communication network forms the transport fabric upon which sensing measurements and control signals rely. Seemingly ever-advancing technologies must be readily integrated into such a communication fabric.

**Key operational parameters:** Robust, cybersecure support of multiple communications technologies and protocols. Seamless integration into existing utility networks. Forward looking technology to advance the IoT and related sensing technologies and utility communication core fabric networks.

#### **1: Develop Compendium of (Principal) IT/OT Network Architectures**

Utilities from co-ops to investor-owned utilities rely on communication network designs provided by vendors and/or best practice guides. While commonality exists across various designs, the next-generation distributed communication architecture(s) for energy delivery systems must provide a wider range of operational skills than previous/current designs. The ad-hoc adoption of IoT/IIoT devices and systems into all facets of utility operation with simultaneous integration of various communications technologies places restrictions on

cost-effective implementation of the fabric and associated devices.

**Key measurement parameters:** Cost, performance, complexity of network elements

#### **Key metrics:**

Ease of integration of designed distributed communication architectures by project's utility Tech Advisory Board.

**Attributes:** Reliability, resiliency, security

**EGS level:** Component state

**Scope of activity:** Architecture development at laboratory scale, followed by pilot-scale deployment and testing and ultimately technology transition to industry

#### **2: Spectrum Management, 5G and Cybersecurity**

Related activities in spectrum congestion management should be leveraged—specifically, the Networking and Information Technology Research and Development Shared Spectrum work in cellular 5G (and future) transport, and cybersecurity projects (e.g., Cybersecurity for Energy Delivery Systems)—to address increasing needs for high data throughput, lower latency, varying data rates, multiple parameter/class of information, and transport throughout utility service areas. Resource allocation schemes under dynamic scenarios should be designed and developed, and optimization techniques can be leveraged to facilitate the objective.

**Key measurement parameters:** Multiple parameter/data sequence throughput, latency, spectrum interference ratio, cyber testing using best practice guides and methods (ICS-CERT)

#### **Key metrics:**

Estimated cost of system deployment, ease of integration into legacy networks, reliability (>99.999%). Providing the throughput required by the corresponding smart grid application. Interference management to acceptable SINRs (signal to interference plus noise rates) corresponding to specific radio frequencies and data rates. Overall spectrum

utilization and performance satisfaction of different smart grid applications. End-to-end overall latency (as low as 1 ms).

**Attributes:** Reliability, resiliency, security.

**EGS level:** Component state, convergent network state, electrical state

**Scope of activity:** Architecture technology development at laboratory scale, followed by pilot-scale deployment and testing and ultimately technology transition to industry

#### **3: Integration with Multiple Project Sensor Development and Distribution Grid Asset Working Groups**

Multiple projects involve developing sensors and systems with varying time scales and measurement transport needs. The objective is collation of the projects' needs for architecture communication backbone implications (wireless, wired, optical).

**Key measurement parameters:** Latency, data throughput, multiple communication technology integration ported to utility network fabric and SCADA core.

#### **Key metrics:**

Utility IT/OT department acceptance of multimedia communication architecture, proven cybersecurity interrogation and operation across scalable architecture

**Attributes:** Reliability, resiliency, security

**EGS level:** Component and networking states

**Scope of activity:** Technology development and demonstration at laboratory scale, followed by pilot-scale deployment and testing and ultimately technology transition to industry

8. COMMUNICATIONS | Distributed Communications Architectures

DOE Lab Contact: Peter Fuhr & Marissa Morales-Rodriguez (ORNL)	Priority	Rank	FY2017	FY2018	FY2019	FY2020	FY2025	FY2030	EGS					Attributes												
									Asset - Geospatial Information	Asset - Status	Asset - Type/Config	Asset - Condition	System - Structure	System - Markets	System - Electrical	System - Thermal	System - Communications	Ambient - Weather	Ambient - Other	Reliable	Secure	Affordable	Flexible	Resilient	Sustainable	
Develop Compendium of (principal) IT/OT Network Architectures	1	1																								
Spectrum Management, 5G and Cybersecurity	2	2																								
Integration with Project Sensor Development and Distribution Grid Asset Working Groups	2	3																								

Research Timeline Legend:

-  early stage research @ TRL 1-3
-  software/hardware/other development & testing and begin interfacing with standards organizations, @ TRL 3-5
-  integration and testing @ TRL 5-7+
-  field validation and testing
-  working with organizations to refine interoperability standards

## Communications and Networking—R&D Thrusts

With the fast development of new communication and networking technologies, especially the IoT and 5G, it is worth investigating how to leverage these new grid modernization breakthroughs to support large-scale deployment of distributed sensors. The first important issue is to identify the inadequacy of the existing communication and networking techniques used for sensing and measurements in the power grid, which serves as the motivation for investigating and deploying new technologies. To leverage the emerging IoT technologies, one important task is to capture the properties of power system operation and control, which is different from the IT domain. In addition, new networking technologies (e.g., software-defined networking [SDN] and network function virtualization [NFV]) can be applied to address the challenges of scalability, diverse quality of service requirements, efficient network management, and reliability and resilience. Another challenge is the interoperability among diverse items of equipment and standards. Tackling this issue could not only make the modern electric grid compatible to legacy systems existing for decades, but also provide an efficient solution for integration of future systems. This focus area includes research thrusts that facilitate the development of the interoperability solution.

**Key objective:** Develop communication and networking technologies to support large-scale deployment of distributed sensors in grids

### **1: Leverage IoT Technologies in Power System Communications**

Emerging IoT and 5G communication technologies have potential for application in the electric power grid to tackle several challenges, especially applications for sensing in distributed system environments, which have several features in common with IoT applications. On the other hand, power system operation and control have unique properties that are different from scenarios of general IoT solutions. These characteristics should be integrated in designing communication solutions for sensing and measurement in power systems by leveraging IoT technologies.

#### **Key metrics:**

- End-to-end overall latency (as low as 1ms)
- Reliability (>99.999%)
- Throughput to meet the corresponding smart grid application
- Power consumption to meet power options of the corresponding device (for battery-powered devices, >10 years of battery-replacement)

- Communication range to meet corresponding smart grid applications
- Number of devices in the network/cluster (scalability up to 5 million nodes)
- Robust security (compliance with NERC Critical Infrastructure Protection, or CIP, standard)

**Attributes:** Reliable, secure, affordable, flexible

**EGS level:** Electrical state, convergent network state

**Scope of activity:** Conduct collaborative studies by academia and national labs. These include theoretical analysis and simulation case studies, followed by facility testing by industry.

### **2: Networking Technologies for Scalability Issues while Satisfying Diverse QoS Requirements**

The large-scale deployment of distributed sensors raises the issue of scalability. A hierarchical architectural design is adopted with several tiers. The new networking technologies need to simplify the local control at each tier and provide coordination among tiers to reduce response time and operational cost. Meanwhile, the quality-of-service requirements for different applications/services should be satisfied by allocating the network resources optimally and dynamically. The SDN technologies, which provide global visibility of the network, could be leveraged to facilitate the optimal resource allocation to tackle these challenges.

#### **Key metrics:**

- Scalability (up to 5 million nodes)
- Quality-of-support support for various smart grid applications (e.g., for latency as low as 1 ms for protection application)
- Support heterogeneous communication technologies

**Attributes:** Reliable, secure, flexible

**EGS level:** Electrical state, convergent network state

**Scope of activity:** Conduct studies by academia and national labs to design the methodologies, followed by collaborative studies with industry to evaluate and validate the methods.

### **3: Efficient Network Management to Support New and Dynamic Services**

The future electric grid will enable highly dynamic and “plug-and-play” system functionalities with large-scale integration of distributed resources and the associated sensing and measurement devices. As a result, new services with dynamic features will prevail which pose challenges to network management. The emerging networking technologies, e.g., SDN and NFV, provide viable solutions to tackle the challenges. However, in applying them to the electric power grid, the features of the physical power system should be integrated.

#### **Key metrics**

- Support for dynamic network services (plug-and-play enabled)
- Support for adaptive scheduling and resource allocation
- Ensuring overhead of network management protocols satisfy end-to-end latency requirements (as low as 1ms)

**Attributes:** Affordable, flexible

**EGS level:** Electrical state, convergent network state

**Scope of activity:** Conduct collaborative studies by academia and national labs for methodology development and simulation case studies, followed by facility testing by industry.

### **4: Reliability and Resilience Enabled by Networking Technologies**

The self-healing properties of the communication network provide reliable and resilient solutions to incidents caused by either faults or malicious attacks. The self-healing scheme aims to use the network resources to find alternative paths to enable communication functionalities to respond after incidents on the sensor networks, which should be addressed by the networking technologies. New networking technologies such as SDN have advantages in terms of global visibility and controllability, which can be used to design self-healing schemes to enhance the reliability and resilience of communication networks. The cyber-physical features of both sensing applications and communication networks should be considered in the design.

#### **Key metrics:**

- Reliability (>99.999%)
- Resilience—There is no consensus on the definition of resilience; some quantifications are suggested:
  - Minimum node density/neighbor nodes required to keep the network alive

- The extent of loss a network can tolerate and still provide a certain percentage (e.g., 90%) of service or critical services.
- Security (compliance with NERC CIP standard)

**Attributes:** Reliable, resilient

**EGS level:** Electrical state, convergent network state

**Scope of activity:** Conduct studies by academia and national labs to develop the algorithms, followed by collaborative studies with industry to evaluate and validate the methods.

### 5: Large-Scale Co-Simulation of Cyber-Physical System Integrating Interoperability Solution

Co-simulation of communication systems and power system

operation and control is a viable tool for testing and validating interoperability solutions. As distributed architecture (e.g. OpenFMB framework) pushes the intelligence to the grid edge, there are several technical challenges in the communication systems—e.g., time synchronization of local communication, routing difficulties, and scalability issues. These issues will also impact the performance of the various power system applications based on sensing and measurements. A large-scale co-simulation tool can help to evaluate interoperability solution performance and study its impacts.

**Key metrics:**

- Scaling from microgrids to a feeder to multiple feeders at a substation to inter-substation interactions
- Heterogeneous hardware such as fiber, copper, power line carrier, mesh networks, point-to-point radios, Long-Term Evolution cellular, and maybe someday GHz cellular

- Multiple standards and protocols supported
- Suitability for the distributed architecture
- Adaptability to use cases regarding sensing and measurements

**Attributes:** Reliable, secure, flexible, resilient

**EGS level:** Electrical state, convergent network state

**Scope of activity:** Conduct studies by academia and national labs to develop co-simulation tools, followed by collaborative studies with industry to evaluate and validate interoperability solutions.

9. COMMUNICATIONS | Communications and Networking Technologies

DOE Lab Contact: **Chen Chen(ANL)**

	Priority	Rank	FY2017	FY2018	FY2019	FY2020	FY2025	FY2030	Asset: Geospatial Information	Asset: Status	Asset: Type/Config	Asset: Condition	System: Structure	System: Markets	System: Electrical	System: Thermal	Ambient: Communications	Ambient: Weather	Reliable	Secure	Affordable	Flexible	Resilient	Sustainable
Reliability and Resilience enabled by Networking Technologies	1	1	🔍	🔍	🔍	🔍	🔍	🔍	🔍	🔍	🔍	🔍	🔍	🔍	🔍	🔍	🔍	🔍	🔍	🔍	🔍	🔍	🔍	🔍
Leverage IoT Technologies in Power System Communications	2	2	🔍	🔍	🔍	🔍	🔍	🔍	🔍	🔍	🔍	🔍	🔍	🔍	🔍	🔍	🔍	🔍	🔍	🔍	🔍	🔍	🔍	🔍
Networking Technologies for Scalability Issue while Satisfying Diverse QoS Requirements	3	3	🔍	🔍	🔍	🔍	🔍	🔍	🔍	🔍	🔍	🔍	🔍	🔍	🔍	🔍	🔍	🔍	🔍	🔍	🔍	🔍	🔍	🔍
Large-scale Co-simulation of Cyber-Physical System Integrating Interoperability Solution	3	4	🔍	🔍	🔍	🔍	🔍	🔍	🔍	🔍	🔍	🔍	🔍	🔍	🔍	🔍	🔍	🔍	🔍	🔍	🔍	🔍	🔍	🔍
Efficient Network Management to Support New and Dynamic Services	3	5	🔍	🔍	🔍	🔍	🔍	🔍	🔍	🔍	🔍	🔍	🔍	🔍	🔍	🔍	🔍	🔍	🔍	🔍	🔍	🔍	🔍	🔍

Research Timeline Legend:

-  early stage research @ TRL 1-3
-  software/hardware/other development & testing and begin interfacing with standards organizations, @ TRL 3-5
-  integration and testing @ TRL 5-7+
-  field validation and testing
-  working with organizations to refine interoperability standards

## DATA, ANALYTICS, AND MODELING

### Big Data Management—R&D Thrusts

With increasing complexity comes increasing need for holistic system insight. It is no longer sufficient to silo parts of the data management system and operate them independently, as there is increasing interconnection between different parts of the power system from DERs and distributed controls. Advanced analytic algorithms have capabilities that far exceed existing methods, but they require data from multiple domains and multiple measurement areas, potentially synchronized and of sufficient quality for analytics. The technology for collecting and ingesting data must be considered, allowing for the application of advanced analytics with the operator at the top of the chain making/guiding (in the case of computer recommendations) decisions about how to best operate the grid. The massive amount of available data and analytics need to be distilled down to simple, easy-to-use displays that give operators the information they need to do their challenging jobs effectively.

The power grid is becoming more highly networked as it transitions to a modern power system with key features such as two-way power flow, distributed generation and storage, and responsive loads. As a result of this high degree of connectivity, there has been a significant increase in both the volume and variety of data created to monitor and control the power system. These data represent a significant opportunity for existing and future applications that can intelligently operate on such a diverse data set. But for these applications to be successful, the data must be maintained in a coherent fashion; and it must be accessible both from a technological perspective through user and machine interfaces, and by being organized so as to be understandable and coherent.

**Key objectives:** security, maintainability, reliability, accessibility, cost.

### **1 Data Access and Interfaces**

There are many uses and users of the data produced by sensing/measurement systems on large power systems, and each of these uses may impose a different set of constraints on data access mechanisms. For example, some applications require access to large amounts of historical data, whereas others require access to small amounts of recently generated data, but at very high rates. To be truly useful, a data management system—or suite of systems—must provide mechanisms for satisfying the constraints of a variety of existing data access requirements while maintaining the flexibility to support future applications. Research efforts must enumerate a reasonably comprehensive set of existing data access requirements, predict future data access trends, and propose data management architectures that will satisfy both in a cost-effective manner.

A key source of errors in software applications is in the interfaces between applications. In this case, many different systems collect the data and must present them in a consistent fashion to an analytic application. These interfaces need to be simple, reliable, and standardized. Otherwise the cost of maintaining and operating a system would greatly exceed any potential value.

**Key metrics:** Latency (<1 ms), cost, storage, ease of installation and maintenance, ease of use, flexibility, standardization, number of language bindings.

**Attributes:** Resiliency, flexibility, security.

**EGS level:** All

**Scope of activity:** Enumeration of detailed requirements of primary applications and projected future applications  
Characterization of value-based metrics for evaluating commercial/ specialized solutions. Identification of data sources and ingestion methods and requirements. identification

of collection technologies and storage solutions, as well as valuation metrics. Interaction with the communication systems.

### **2 Data Organization, Visualization, and Fusion**

The wide range of data types and data rates originating in large power systems stretches the capabilities of traditional tools for organizing data. These tools must support data sources ranging from short bursts at rates of several kilohertz to one-off manual data entry. Despite the great variety in rates and content, future data analytic systems may be able to make use of all existing and future sources. To support these applications, the data must be organized in a consistent yet flexible manner and must be protected to varying levels. Research efforts must identify applicable schemes to successfully manage and archive the wide range of existing and future data sources. The human electric grid operators play a key role in assessing and managing the grid. To be effective, advanced applications need to be accessible, trusted, and easily understandable by these grid operators. Visualization tools and other operator tools must enhance the abilities of the grid operators to operate the grid in an effective and reliable manner, both under normal circumstances and under stress.

**Key metrics:** Ease of setup, cost, ease of access, flexibility, management requirements.

**Attributes:** Resiliency, flexibility, coherency, security

**EGS level:** All

**Scope of activity:** Enumerate organizational requirements and value. Evaluate existing standards and technologies. Establish a recommended set of best practices and standardized solutions.



## Analytics Support and Integration—R&D Thrusts

Evaluation and maintenance of grid health currently depends on a centralized, deterministic approach in which data are collected and analyzed, and some control action is then taken. In contrast to traditional centralized grid data monitoring and analysis, building component health relies on a decentralized analytic approach in which each building component is monitored and analyzed individually. For performance and reliability reasons and the large scale of some potential applications, there is a need to support distributed analytics and control algorithms across the grid. Efficient and accurate data management systems must be in place to ensure that data are distributed where needed on time and reliably and that the results are consistent and accurate. This needs to be done in a manner that delivers consistent value in a secure fashion to be economical for utilities and customers.

Mere availability of more data will not, by itself, lead to changes in grid visibility, security, and resiliency. To create the predictive and prescriptive environment required to enable new markets and transactions for customer revenue and a reliable grid, the data must be collected, organized, evaluated, and analyzed using sophisticated pattern-detection (i.e., incipient failure analysis can have subtle signatures recognizable only by advanced analytics) and discovery algorithms to provide actionable information allowing operators to reliably manage an increasingly complex grid.

**Key objectives:** Accuracy, performance, security, value

### **1 Analytics Integration and Platform Development**

Characteristics of the distribution grid that make it daunting for conventional analysis but ideal for application of machine learning are randomness of customer behavior, high nodal volume, lack of useful metadata, and the number of unknowns such as grid topology and availability of behind-the-meter resources. Fundamental research is needed to integrate advances in existing machine learning techniques and develop platforms on which new analytics can be deployed that account for power-systems physics and variability at the building-to-grid interface, are secure with low computational burden, and are easily deployed. Analytics developed through this work must have integration capabilities through unified data models, with upper hierarchical utility systems, without the introduction of further information quality issues.

**Key metrics:** Latency, reliability, correctness, cost

**Attributes:** Resiliency, sustainability, reliability, flexibility

**EGS level:** Component state, electrical state, ambient state, topological state

**Scope of activity:** Development, review, and demonstration of distributed analytics platforms that draw upon multivariate measured data to enable applications, and demonstration of integration of distributed data layers to upper centralized architecture

### **2 Data Preparation and Evaluation (Validation, Quality Assessment, Conditioning/Correction)**

While new sensors and data sources for the grid represent a valuable source of information, these streams will inevitably contain errors due to miscalibrated sensors, communication problems, or equipment failures, among many other possible causes. These errors, unless properly identified and corrected in a consistent fashion, will infect and retard all downstream efforts to use the data either for analysis or to drive applications.

When these data quality issues arise, it can be challenging to distinguish between anomalous grid behavior and anomalous data. Customized data checking and validation system and detection of bad data in every data stream are at present not scalable nor automated. Bad data are often found after they have been ingested and stored, when analysis is attempted. Machine learning methods can be used to monitor the quality of data and detect anomalous readings, do online calibration in coordination with otherwise redundant system information, and compare measurements across different time scales to improve the accuracy and value of any downstream system.

The systems that might use distributed analytics may be very complex. Some sort of monitoring, verification, and evaluation system must be in place to ensure the distributed processing across the grid is performing effectively and not experiencing issues that could be related to cybersecurity, communication, or data system degradation. This will require additional data, communication, and monitoring on the analytic systems themselves. One example is satellite lock in GPS-based time synchronization, as an additional data stream from the measurement device that indicates the health of the data themselves.

**Key metrics:** Reliability, correctness, cost

**Attributes:** Resiliency, sustainability, reliability, flexibility

**EGS level:** Component state, electrical state

**Scope of activity:** Develop and demonstrate machine learning techniques to monitor data quality, improve calibration, and identify potential system issues using reported data streams. Conduct collaborative studies among academia, national labs and industries, making use of co-simulation capabilities to identify system performance indicators and vectors for performance degradation through the chain of data and information. Metrics will be developed for which each data stream will be investigated.

### **3 Multi-Modal Multivariate Algorithms**

A significant volume of analyses is already being proposed for the power grid/buildings interface. Analyses such as consumption, forecast of load, and outages at present often rely on single data sources; as an example, a smart meter's on/off status can be used to diagnose an outage location. Within the existing analytics platforms, where techniques such as machine learning are already implemented, there are numerous instances of siloed data sources and techniques. The analytics developed are often specific to the grid and sensor architecture, meaning analytics do not thrive upon the wealth of data available and are dependent on single-source accuracy. Research is required to implement both multimodal and multivariate techniques for present and future grid data sources. There is a need for development of advanced analytics techniques combined with motivating applications as a core foundational focus to realize the objectives of the sensing and measurement strategy. The first step is actually ingesting or accessing the data from many legacy applications and multimodal sources, as well as new sensors and systems. Data from many networks, including the T&D electrical network, weather networks, communication network traffic, forecasting systems, Twitter feeds, asset management, and many others may require fusing. All these data need to be gathered by or accessible to one or more advanced analytic processing applications in a consistent, cost-effective manner.

**Key metrics:** Latency, reliability, correctness, cost

**Attributes:** Resiliency, sustainability, reliability, flexibility

**EGS level:** Component state, electrical state

**Scope of activity:** Development and demonstration of multimodal, multivariate machine learning techniques for real-time and predictive analysis of a wide range of grid conditions as presented in the use cases.



## Advanced Data Analytics Techniques and Applications

**Problem:** There is a need for development of advanced analytics techniques combined with motivating applications as a core foundational requirement to realize the objectives of the sensing and measurement strategy.

### Definition of metrics

- Local—Analytics performed at, on, and for a single sensor/asset location without input from other devices. Data do not leave the device in question.
  - Distributed—Analytics and decisions are made across sensors/assets distributed in space and time. Data are shared across the network but not consolidated to a single location.
  - Centralized—Analytics and decision making (computations) are performed at a single central location. Data must be moved to this location.
- Retrospective (historical)—Computations are performed on data stored from a time in the past.
  - Real-time (present)—Computations are performed within some window of time of the present moment. This time period often has the most stringent time budget requirements.
  - Predictive (future)—Refers to all analytics whose results are estimates of future values. The time budget for this computation is dependent on how far into the future the prediction is made.

### Metrics for data management and analytics

Level	Time	Retrospective (past)	Real-time (present)	Predictive (future)
<b>Local</b>		Data acquisition latency: minutes Computational budget: moderate Solution time: minutes Nodes: 1 Scalability: 100K nodes Precision: single node/device Accuracy: <5% root mean square error (RMSE)	Data acquisition latency: 0 to us Computational budget: low Solution time: <microseconds Nodes: 1 Scalability: 1 Precision: single node/device Accuracy: <5% RMSE	Data acquisition latency: ms Computational budget: moderate Solution time: seconds Nodes: 1 Scalability: 1 Precision: single node/device Accuracy: <10% RMSE
<b>Distributed</b>		Data acquisition latency: minutes Computational budget: moderate Solution time: minutes Nodes: 100K Scalability: 1M Precision: high (local decision making) Accuracy: <5% RMSE	Data acquisition latency: microseconds Computational budget: low Solution time: <microseconds Nodes: 100K Scalability: 100K Precision: single node/device Accuracy: <5% RMSE	Data acquisition latency: ms Computational budget: high Solution time: seconds Nodes: 100K Scalability: 100K Precision: single node/device Accuracy: <5% RMSE
<b>Centralized</b>		Data Acquisition Latency: minutes Computational budget: high Solution time: minutes Nodes: 1M Scalability: 10M Precision: single device Accuracy: <5% RMSE	Data acquisition latency: 0 to us Computational budget: high Solution time: <us Nodes: 500K Scalability: 500K Precision: regional Accuracy: <5% RMSE	Data acquisition latency: 0 to us Computational budget: high Solution time: seconds Nodes: 500K Scalability: 500K Precision: regional Accuracy: <10% RMSE

## Weather Sensing Data—R&D Thrusts

This focus area includes research thrusts for advanced modeling using weather sensing data with quantitative metrics where appropriate. There are additional research thrusts related to innovative devices for weather sensors, which appeared earlier under the DEVICES section.

**Key measurement parameters:** Wind speed, wind direction, temperature, humidity, soil moisture, water turbulence (offshore wind), irradiance (GHI, DNI, and diffuse), spectral components, cloud motion, barometric pressure, precipitation, lightning, icing, renewable power generation

**EGS levels:** Topological state, component state, building state, ambient state, convergent networks

### 1 Harnessing Existing Disparate Weather Monitoring Resources and Enabling Their Optimal Use

There is a great amount of weather monitoring and measurement resources in the nation, including ground-mounted sensors, weather stations, mesonets, remote-sensing, and satellite measurements. These resources (such as next-generation GOES satellites) are capable of providing visibility, at high temporal and spatial resolution, into various weather parameters for renewable energy and electricity demand forecasts. Data from weather radar that provide precipitation detection capabilities can be adapted to quantify real-time impacts on PV plant statuses and production estimates. Data quality assurance and standardization of formats are important. Although there have been efforts to standardize meteorological data reporting to a certain extent, such efforts need to extend to the resource forecasting data used by the energy industry. Currently, every utility and ISO has its own data formats to ingest the weather and renewable forecast information for various applications. Standardization in terms of data reporting practices (i.e., measured parameters and their metadata) and forecast integration will be key areas for widespread adoption of weather data. Standards and best practices for calibration of weather sensing devices are also needed.

**Key metrics:** Cost of data acquisition, data availability and redundancy, latency, spatial (<1 km, behind the meter) and temporal (in seconds) coverage, measurement quality (>99% accuracy), high-resolution high-speed weather data curation (>100 terabytes per day)

**Attributes:** Improving energy forecasting, reducing data acquisition costs, enabling entry of nondomain (power) experts for grid modernization, workforce training, high-quality data, decision aid tools that enable seamless weather data integration, and cyber security

**Scope of activity:** (1) Create a consortium of key personnel responsible for measurement, generation, communication, assimilation, and end-use. (2) Facilitate public and private partnerships, standards development. (3) Develop comprehensive documentation of disparate weather sensing resources. (4) Work with utilities and ISOs to understand format variations and their rationales. (5) Develop and enforce industry best practices for weather monitoring sensor deployment, maintenance and operation. (6) Consider Pareto front of weather sensing infrastructure cost vs. system performance (e.g., reliability, flexibility, observability).

### 2 Advanced Modeling of Resource Observability and Forecasting

Advancements in weather forecasting models have contributed to better forecasting of energy supply and demand. However, utilities still have limited visibility of feeder-level or substation-level net loads. This impacts grid management applications, including bulk system reserve allocations, distribution system fault detection, and voltage management. The future grid requires innovative models that can provide real-time production and forecasts at very high spatial and temporal resolution for behind-the-meter renewables and loads. This will necessitate development of cloud retrieval and of radiative transfer algorithms that enable real-time processing of very high-resolution satellite data. Localized forecasts using sky camera technologies require a significant increase in accuracy and decrease in latency that can be realized only through innovative modeling techniques. Additionally, current forecasting models are not capable of predicting clouds and the consequent solar radiation with the required accuracy necessary for future grid applications. Improvements in the understanding of the physics of cloud development, sustenance, and dissipation, and innovations in assimilation of newer measurements, are necessary to transform the current state of the art. The use of tools such as big data analytics in addition to typical weather forecasting models, including numerical weather prediction, will have an important role to play.

**Key metrics:** Improvement of forecast accuracy of renewable generation, ramps, and the consequent net load at different locations (>30–40% compared with state-of-

the-art practices; probabilistic forecasts: >95% accuracy in uncertainty coverage and <5% mean bias error); spatial (<1 km, behind the meter) and temporal (5–15 min. for real-time dispatch, hourly for day-ahead) coverage

**Attributes:** Variable renewable integration, net-load forecasts, advanced T&D market design, lean reserves, resilience, operational flexibility, optimization of cost and reliability

**Scope of activity:** (1) Develop advanced forecasting models for probabilistic forecasts of load, variable renewables, and net-load power and ramps. (2) Work with industry to evaluate the value proposition and recommended best practices for advanced forecast integration. (3) Validate satellite data based on ground-mounted sensors and the resulting forecasting models.

### 3 Weather-Dependent High-Impact Event Modeling

Weather data is a key piece in developing decision support tools for severe resilience events. More than 70% of outages are correlated with weather events. Even without considering very severe weather events—such as high wind, lightning, storms, forest fires, and floods—shorter duration (<4 hour) outages can hamper industrial activity and cause economic losses. On average, the US economy loses \$104–164 billion a year to outages, and this could increase depending on the frequency of severe events. Integration of variable renewables that depend on weather forecasts adds complexity for both (1) predicting the impact of their variability and uncertainty and (2) their roles and impacts on system recovery with synergic storage systems. The impact modeling of severe weather goes beyond the electrical grid to other interdependent infrastructure such as gas and transportation.

Research will include ingesting severe weather events into visualization tools; translating the weather propagation models into grid impacts; and overlaying the evolution of severe weather events on the GIS data for distribution grids, critical loading facilities, and emergency shelters. Understanding the distributed solar and DER (storage, fuel cell) locations will also be valuable for (1) identifying which locations and associated grid assets and customers will be affected and (2) developing short-term and long-term preparedness or preventive strategies, including strategic system restoration based on real-time sensors.

**Key metrics:** Flood prediction, short-term forecast accuracy (>95% reliability or uncertainty coverage of

probabilistic forecasts), low latency or rate of forecast updates (seconds to minutes), accuracy of ramp alerts (<5% false alarms and risks)

**Attributes:** Situational awareness for grid operators, tree trimming management, resilience, flexibility, real-time decision support (local decisions), reduced curtailment, reduced number and duration of customer outages, fewer

crew truck rolls, increased value proposition for variable renewables and their synergic storage/demand response technologies

**Scope of activity:** (1) Work with ISOs, utility, weather scientists, and vendors to develop visualization software that can integrate live forecast feeds to demand management system/emergency management system

platforms and relate them to probable grid outages. (2) Quantify the uncertainty of weather events and their impacts on preparedness to enable resilience at low cost. (3) Develop decision support tools that use weather data to identify severe weather warnings and hotspots in the power grid or customer outages.

12. DATA, ANALYTICS, & MODELING | Weather data for grid modernization

DOE Lab Contact: Venkat Krishnan (NREL)	Priority	Rank	FY2017	FY2018	FY2019	FY2020	FY2025	FY2030	EGS							Attributes									
									Asset: Geospatial Information	Asset: Status	Asset: Type/Config	Asset: Condition	System: Structure	System: Markets	System: Electrical	System: Thermal	System: Communications	Ambient: Weather	Ambient: Other	Reliable	Secure	Affordable	Flexible	Resilient	Sustainable
Advanced modeling of resource observability and forecasting	1	1	🔍	🔍	🔍	🔍	🔍	🔍	🔍	🔍	🔍	🔍	🔍	🔍	🔍	🔍	🔍	🔍	🔍	🔍	🔍	🔍	🔍	🔍	🔍
Integrating high impact weather situations for grid resilience	1	2	🔍	🔍	🔍	🔍	🔍	🔍	🔍	🔍	🔍	🔍	🔍	🔍	🔍	🔍	🔍	🔍	🔍	🔍	🔍	🔍	🔍	🔍	🔍
Harnessing existing weather monitoring resources and integrating innovative technologies	2	3		🔍	🔍	🔍	🔍	🔍	🔍	🔍	🔍	🔍	🔍	🔍	🔍	🔍	🔍	🔍	🔍	🔍	🔍	🔍	🔍	🔍	🔍

Research Timeline Legend:

-  early stage research @ TRL 1-3
-  software/hardware/other development & testing and begin interfacing with standards organizations, @ TRL 3-5
-  integration and testing @ TRL 5-7+
-  field validation and testing
-  working with organizations to refine interoperability standards

## APPENDIX A. DEFINITIONS

<b>Abnormality</b>	A condition, state, or quality that is not normal in terms of expected condition or outcome.
<b>Accuracy</b>	More commonly, is a description of systematic errors, a measure of statistical bias, as these cause a difference between a result and a “true” value. ISO calls this trueness. Alternatively, ISO defines “accuracy” as describing a combination of both types of observational error (random and systematic), so high accuracy requires both high precision and high trueness.
<b>Affordable</b>	Inexpensive or reasonably priced and within the financial requirements for providing a short payback period for benefits.
<b>Automatic generation control (AGC)</b>	Automatic generation control enables equipment to automatically adjust generation in a balancing authority (BA) area from a central location. It provides the function of maintaining the BA’s interchange schedule plus frequency bias.
<b>Ambient state</b>	The state of the current operating surroundings of system operation, usually in relation to the environment. For power systems, it refers to the external conditions that affect it, such as weather and operational constraints such as environmental emissions rules, NERC reliability standards, and a variety of dispatch and market rules.
<b>Angle resolution</b>	The smallest change in the value of an angle that can be reasonably measured by a measurement device (sensor).
<b>Backhaul</b>	In a hierarchical telecommunication network, the backhaul portion of the network comprises the intermediate links between the core network, or backbone network, and the small subnetworks at the edge of the entire hierarchical network.
<b>Behind the meter</b>	A location on the customer/owner side of the electric (kWH) meter. This is opposed to being on the utility or grid side of the kWH meter.
<b>Building management system</b>	A computer-based control system installed in a building that controls and monitors the building's mechanical and electrical equipment, such as ventilation, lighting, electrical systems, fire systems, and security systems.
<b>Building state</b>	The status of a building’s operating condition as described by measurements, such as indoor temperature; and operating state of the heating, ventilation, and air-conditioning, and other parameters, at a particular time.
<b>Bus voltage</b>	In a power system, those voltages at the main source, such as a substation or a connection point along the circuit. It is usually specified for power system power flow studies. For electronics, it is a voltage that supplies all the circuits of an electronics system.
<b>Calibration</b>	The comparison and verification of measurement values delivered by instrumentation under test with those of a calibration standard of known accuracy.
<b>Cybersecurity for Energy Delivery Systems (CEDs)</b>	Provision of security measures (in hardware/software) to protect against cyberattacks such as software hacking by intrusion by outsiders.
<b>Centralized vs. decentralized</b>	These are two typical and diverse system structures. In a centralized structure, a central unit gathers all the information and exercises control over the lower-level components of the system directly. In a decentralized structure, complex behavior emerges through the lower-level components operating on local information without the control of a central unit.

<b>Cooperative (co-op)</b>	An organization such as an electric utility provider that is jointly run and owned by its members.
<b>Co-simulation</b>	Different subsystems that form a coupled problem are modeled and simulated in a distributed manner. In electric power systems, co-simulation is usually performed on electric power grids and communication networks.
<b>Communication architecture</b>	The hierarchical structural design of communication systems/networks. It refers to the topology and configuration of the communication hardware and software and operating characteristics.
<b>Component network state</b>	Status of data communication services of a communication network component like a router or switch.
<b>Conventional generation</b>	Electric generation from large power plants that have fossil fuels, nuclear power, or natural gas as their source of energy, in contrast to renewable generation that has wind, solar or hydro as its energy sources.
<b>Convergent network state</b>	State of data communication services within a single network. Network convergence is primarily driven by the development of technology and demand.
<b>Cyber-physical system (CPS)</b>	A system composed of physical components controlled by computer-based algorithms. The tight conjoining of and coordination between computational and physical resources.
<b>Cycle (time)</b>	A signal is periodic if it completes a pattern (such as a sinewave) within a measurable time frame (period) and repeats that pattern over identical subsequent periods. The completion of a full pattern within a time period is called a cycle.
<b>Cycling</b>	A signal is cycling when it repeats a pattern within a measurable time frame.
<b>Data access</b>	Software and data management activities related to processing, storing, retrieving, or acting on data gathered in a database or other repository or delivered to one of these from a data source, such as a sensor or measurement system.
<b>Data analytics</b>	A process of inspecting, cleansing, filtering, processing, transforming, and modeling data with the goal of discovering useful information from the data to draw conclusions and support decision-making. Also known as data analysis.
<b>Data quality</b>	The condition of data quantities with regard to completeness, soundness, and accuracy.
<b>Data validation</b>	The process of ensuring that data are of high quality
<b>Demand response</b>	Changes in an end-use customer's electric power demand/usage from the normal consumption pattern as a response to incentives. It can be in response to electricity price signals (i.e., changes in the price of electricity over time), or to incentive payments offered by the utility designed to induce lower electricity demand/use at times of high wholesale market use/prices or when system reliability is jeopardized.
<b>Distributed energy resource (DER)</b>	DERs generate electricity from small-head hydro, wind, or solar power (if renewable) and fossil fuel (if not). They are typically located near end-use customers that use them to produce their own electricity or offset their electric demand. These power sources can be aggregated by third parties to provide power necessary to meet regular electricity demand/use.
<b>Diffuse horizontal irradiance</b>	The amount of solar radiation received per unit of area on a surface indirectly from the sun on a surface that has been scattered (diffuse) in the atmosphere.
<b>Distributed</b>	Spread out in various locations, as opposed to being located centrally at one place.
<b>Distributed generation</b>	Electrical generation and storage performed by a variety of small (compared with central generation plants) grid-connected devices.

<b>Direct normal irradiance</b>	The amount of solar radiation received per unit of area on a surface directly from the sun
<b>Dynamic</b>	A process or system characterized by constant change, activity, or progress.
<b>Dynamic range</b>	The range of dynamic operation, such as transmission line dynamic loading, in terms of its minimum to maximum value.
<b>Electric topology</b>	The configuration of the electric power network in terms of interconnections of the circuits and components.
<b>Electrical state</b>	The status of the electric system described by electrical measurements at a location and time.
<b>Embedded sensor</b>	A sensor embedded (integrated) into a microprocessor system for signal acquisition.
<b>Energy management system (EMS)</b>	A system of computer-aided tools used by system operators of electric utility grids to monitor, control, and optimize the performance of the electric power generation and/or transmission system.
<b>Extended grid state (EGS)</b>	To address the future needs of the modern grid, the concept of grid state must be extended to include all aspects of the electrical power state for distribution systems and elements that address DERs, including those that are not utility owned, such as energy storage and new electronic loads. The EGS definition includes both utility and customer assets in the distribution system and connectivity with the transmission system.
<b>Flexible AC transmission system (FACTS)</b>	A hardware/software system, generally power electronics based, used for the flexible control of power on the transmission system.
<b>Fault</b>	An abnormal electric current due to the short-circuiting of the power system, such as a leaning tree causing a short-circuit (fault) on the distribution system.
<b>Flexible</b>	The ability of an entity, such as the power system, to adjust controls, protection, and so on to respond to changes in operating conditions/states, such as changes in electric supply/demand and/or from normal to emergency conditions.
<b>Flexible generation</b>	Electric power generation with the ability to change its operating condition quickly, for example, to start and stop on short notice, change its output (ramp) rapidly, or achieve and maintain a low minimum operating level.
<b>Frequency monitoring network (FNET) device</b>	“FNET” is a low-cost, quickly deployable, GPS-synchronized wide-area frequency measurement network deployed by the University of Tennessee. Frequency disturbance recorders (FDRs)—GPS-synchronized single-phase phasor measurement units (PMUs) installed at ordinary 120 V electrical outlets—are used in the FNET system to measure local voltage/angle and frequency as well as grid frequency. Because the voltages at which FDRs are connected are much lower than those of a typical three-phase PMU, the devices are relatively inexpensive and simple to install. They can be installed in buildings/homes without all of the requirements the PMUs need for installation in substations.
<b>Frequency</b>	The number of occurrences of a repeating event per unit of time.
<b>Geomagnetically induced current (GIC), geomagnetic disturbance (GMD)</b>	GIC and GMD events, which induce DC voltages and currents on the electric power system, are caused by solar flares ejected from the surface of the sun.

<b>Global horizontal irradiance (GHI)</b>	The amount of short-wave radiation received on the surface horizontal to the ground and the total of direct normal irradiance, diffuse horizontal irradiance, and ground reflected radiation.
<b>Grid Modernization Initiative</b>	An initiative created by the US Department of Energy (DOE) to create the electrical power grid of the future.
<b>Grid Modernization Laboratory Consortium (GMLC)</b>	A strategic partnership established between DOE and its national laboratories to bring together leading experts, technologies, and resources to collaborate on the goal of modernizing the nation’s grid.
<b>Grid hardening</b>	Strengthening electrical assets to withstand major storm events, which include high winds, lightning, flooding, and heavy snow and ice.
<b>Grid optimization</b>	Selection of interrelated decisions on planning, operating, and controlling power grid assets that maximize an objective, such as minimizing total cost or maximizing reliability within allowed engineering, market, and regulatory constraints.
<b>High-resolution sensor</b>	The resolution of a sensor is the smallest change that it can detect in the quantity being measured. Thus, high-resolution sensors can detect very fine or extremely small changes in a measured quantity.
<b>Human interface device</b>	A device (e.g., keyboard, mouse) by which humans provide input to and output from a computer-based system. In the industrial design field of human-computer interaction, it is the space where interactions between humans and machines occur.
<b>Industrial control systems cyber emergency response team (ICS-CERT)</b>	An organization of the US Department of Homeland Security within the National Cybersecurity and Communications Integration Center ( <a href="https://ics-cert.us-cert.gov/about-us">https://ics-cert.us-cert.gov/about-us</a> ) that operates 24/7 to reduce risks within and across all critical infrastructure sectors.
<b>Intrusion detection system/intrusion prevention system/unified threat management (IDS/IPS/UTM)</b>	IDS is hardware/software that monitors a network or systems for malicious or policy violation activity such as hacking. IPS is a threat prevention system that monitors and examines network traffic to detect and prevent vulnerability to intrusion attacks. UTM is a set of security appliances that combine firewall, antivirus and intrusion detection/prevention capabilities into one platform.
<b>Internet of things (IoT)</b>	A network of physical devices—such as computers, phones, home appliances, vehicles, and other devices—embedded with electronics, software, sensors, actuators, and network connectivity that enables these devices to connect and exchange data.
<b>Interoperability</b>	The ability of a product or system of different manufacturers, whose interfaces are completely understood, to work with other products or systems without any restrictions.
<b>Investor-owned utility (IOU)</b>	A privately owned/operated electric utility rather than one operated by the government or a cooperative.
<b>Irradiance</b>	The radiant flux or density of radiation (power in W/m <sup>2</sup> ) received by a surface per unit of area. Solar irradiance is the power per unit area received from the sun.

<b>Latency</b>	The delay in data transfer—for example, a communication delay following an instruction for data transfer. A time interval between the stimulation and response, or, from a more general point of view, a time delay between the cause and the effect of some physical change in the system being observed.
<b>LIDAR (light detection and ranging)</b>	A light and radar technology that measures distance by illuminating a target with a laser light.
<b>Luminance</b>	The intensity of light that passes through, is emitted by, or is reflected from a particular area in a given direction.
<b>Machine learning</b>	A subfield of computer science, which evolved from the study of pattern recognition and artificial intelligence, that enables computers to learn or act without being explicitly programmed.
<b>Measurement</b>	Physical quantities or parameters detected by sensors associated with physical action, events, or phenomena.
<b>Multi-Year Program Plan</b>	The Grid Modernization Multi-Year Program Plan developed by DOE
<b>Narrowband Internet of Things (NB-IoT)</b>	NB-IoT is a low-power wide area network (LPWA) standard that improves power consumption of user devices, system capacity, spectrum efficiency, and deep coverage to enable a wide range of new IoT devices and services.
<b>Network function virtualization</b>	A network architecture concept that uses information technologies to virtualize, or create in software, entire classes of network node functions, which act as building blocks that connect, or chain together, to create communication services. It is a way to reduce cost and accelerate service deployment for network operators by decoupling functions like firewalls or encryption from dedicated hardware and moving them to virtual servers.
<b>Network (WAN, LAN, HAN, NAN)</b>	A network is an interconnection of various devices such as sensors, meters, and switches to communicate and share data via wired or wireless communication. Networks can be differentiated by their reach, i.e., geographical area. A wide area network (WAN) connects regional and national networks together. A local area network (LAN) interconnects various devices within a limited area such as a residence, school, laboratory, university campus or office building. A home area network (HAN) is the connection of network-enabled devices in a residence. A near-me area network (NAN) focuses on wireless communication among devices in close proximity.
<b>Networking and Internet Technology Research and Development Program (NITRD)</b>	“The Networking and Information Technology Research and Development (NITRD) Program is the Nation’s primary source of federally funded work on advanced information technologies (IT) in computing, networking, and software. The multiagency NITRD Program seeks to provide the research and development (R&D) foundations for assuring continued US technological leadership and meeting the needs of the Federal Government for advanced information technologies. The NITRD Program also seeks to accelerate development and deployment of advanced information technologies in order to maintain world leadership in science and engineering, enhance national defense and national and homeland security, improve U.S. productivity and economic competitiveness, protect the environment, and improve the health, education, and quality of life of all Americans. Reference: <a href="https://www.nitrd.gov/about/index.aspx">https://www.nitrd.gov/about/index.aspx</a> .”

<b>Node/nodal</b>	“Node” can refer to a device or a location within a communication network, data system or electric power system. In a communication network, a node/nodal is either a redistribution point or a communication endpoint. In a data system, a node may be either a data communication equipment or data terminal equipment. If the network is a distributed system, the nodes are clients, servers, or peers. In an electric power system, a node can be any point on a circuit where two or more circuits or elements meet and connect.
<b>Operational technology (OT)</b>	Hardware/software that detects or causes changes in response to the monitoring and/or control of physical devices, processes and events in the enterprise system.
<b>Optical transducer</b>	Electronic detector for measuring physical values on the power system by converting light, or a change in light, into an electronic signal. An optical transducer can realize high signal fidelity by intensity modulation using a noncoherent light source that passes through fiber optic cables without being distorted by any saturation effects.
<b>Phasor</b>	A complex number representation of a power system voltage or current waveform. It represents a sinusoidal function of amplitude (A), angular frequency ( $\omega$ ), and angle/phase ( $\theta$ ). It is related to a more general concept called analytic representation, which decomposes a sinusoid into the product of a complex constant and a factor that encapsulates the frequency and time dependence of the signal.
<b>Plug and play</b>	Describes devices that recognize, are recognized by, and work with a network or computer system as soon as they are connected. With this capability, the user does not have to manually install drivers for the device or even tell the computer that a new device has been added. Instead, the network or computer system automatically recognizes the device, loads new drivers for the hardware if needed, and begins to work with the newly connected device.
<b>Phasor measurement unit (PMU)</b>	A device that produces time-synchronized phasors and frequency and rate-of-change-of-frequency (ROCOF) estimates from instantaneous voltage and/or current signals of the power system. The measurements are time-synchronized using a highly accurate time signal, such as GPS signals. Note that the same device may not be a dedicated PMU and may perform other functions and have another functional name (e.g., the device may also record power system waveforms and be called a digital fault recorder or may also perform protection functions, such as those of a relay.)
<b>Plane of array (POA)</b>	The surface of the photovoltaic array. It is important for determining its orientation with respect to the sun to maximize energy production.
<b>Power flow</b>	The flow of electric power on power systems. Also can refer to the solution of voltages and electric power flows in a power system software solution or simulation.
<b>Power quality</b>	The quality of electric power provided for end-use consumers and their devices. It can refer to the level of harmonics, flicker, and other quality characteristics of electric power provided to end users that can affect the operation of various electric loads and appliances.
<b>Power system</b>	The electricity system, consisting of generation resources and transmission facilities, under the management or supervision of an independent system operator, reliability transmission operator, or transmission system operator or owner to meet electric load and/or interchange energy commitments.
<b>PQ node</b>	A measurement device that can be placed near an electric consumer/load to measure the quality of power provided by the utility system.

<b>Precision</b>	The accuracy of a measurement system. It is related to reproducibility and repeatability. It is the degree to which repeated measurements by the measurement system, under unchanged conditions, show the same results.
<b>Quality of service (QoS)</b>	QoS for networks includes transmission rates, error rates, and other network characteristics that can be measured, improved, and to some extent guaranteed in advance. QoS is an industry-wide set of standards and mechanisms for ensuring high-quality network performance for critical applications.
<b>Ramping</b>	Can be related to the ramping either up or down of generation or load. Load ramp is a sudden change in system net load due to changes in energy consumption (e.g., evening load ramp up) and/or renewable energy generation (e.g., evening solar ramp down) or a conventional generation outage (i.e., causing generation-load imbalance). Load ramping needs are typically met by corresponding changes in electric power generators or demand response, which either increase or decrease their power output or consumption. The amount of ramping provided by a resource depends on its ramp-up or ramp-down rates (defined in terms of MW/min).
<b>Real time</b>	Relates to applications in which the hardware and/or software system must respond as rapidly as required by the operator/user or as necessitated by the process being controlled within the physical constraints of the operating system.
<b>Recloser</b>	A self-controlled protection device for automatically interrupting and reclosing an AC circuit on an electric power system, with a predetermined sequence of trips (opening) and reclosing followed by resetting, hold-closed, or lockout operation. Reclosers interrupt temporary faults on an electric circuit, such as a tree momentarily touching an energized line, and lock out the circuit when a fault is a permanent one, such as a downed line.
<b>Registered/unregistered</b>	Registered memory modules have a register between the dynamic random-access memory (DRAM) modules and the system's memory controller. They place less electrical load on the memory controller and allow single systems to remain stable with more memory modules. Compared with registered memory, conventional memory is referred to as unregistered memory.
<b>Reliable</b>	The ability of the electric bulk-power system to withstand sudden disturbances, such as faults (electric short circuits), or the unanticipated loss of system elements, (i.e., generator or transmission line trips), from credible contingencies and still provide a high level of quality of electric power service to end-users.
<b>Renewable generation</b>	The process of generating electric power from renewable energy sources, which are those that are naturally replenished, such as with wind or solar energy.
<b>Requirement</b>	The singular documented physical or functional need that the electric power system generation, transmission, and/or distribution system aims to satisfy.
<b>Resilience/resilient</b>	The ability of the electric power system or its components to adapt to changing system conditions and withstand and rapidly recover from a disrupting event.
<b>Responsive load</b>	Electric end-use loads that can respond to a utility signal such as price to provide reduced load demand, for example, during emergency operation. This type of load can also be used to provide frequency/voltage regulation and spinning reserve.
<b>Restoration</b>	The state of the power system operating state when a stable operating point with partial or total blackout is reached and the process of reconnecting all loads is started. Full restoration is achieved when all loads have been reconnected and the system either enters the alert or the normal operating state.

<b>Root mean squared (RMS)</b>	A mathematical process used to determine average voltage/current over a period of time.
<b>Rate of change of frequency (ROCOF)</b>	The change in system frequency over a certain time. The unit of measurement is Hertz per second or Hz/s.
<b>Supervisory control and data acquisition (SCADA)</b>	The SCADA system is the hardware and software system that provides the remote control and telemetry used to monitor and control the transmission/distribution system of the electric power system.
<b>Scalability</b>	The ability of a system to scale up by using additional or new generations of components.
<b>Scalar</b>	A physical quantity, which has magnitude and no other characteristics, that can be described by a single element of a number field such as a real number, often accompanied by units of measurement. In contrast, vectors and tensors are described by several numbers that characterize their magnitude, direction, and so on.
<b>Security</b>	The ability of the power system to remain operating in a normal state of operation without serious consequences due to any credible system contingencies.
<b>Sensor/sensor device</b>	A device, module, or subsystem whose purpose is to detect events or measure changes in its environment and send the data to other electronics (frequently computer processors) to produce information.
<b>Sensor optimization</b>	Finding a sensor selection and/or allocation with the most cost-effective or highest achievable performance (e.g., in observability, reliability) under given physical and budget constraints, by maximizing desired factors and minimizing undesired ones.
<b>Signal-to-noise ratio (SINR/SNR)</b>	Signal-to-noise ratio
<b>Situational awareness</b>	Awareness of the operating environment and conditions of the electric power system. The perception of elements in the environment within a volume of time and space, the comprehension of their meaning, and the projection of their status in the near future.
<b>Smart meter</b>	An electronic kWh meter that records the consumption of electric energy at the end-use at intervals of an hour or less and communicates that information via wireless or wired communication to the utility for monitoring and billing.
<b>SODAR (sonic detection and ranging)</b>	A meteorological instrument used as a wind profiler to measure scattering of sound waves by atmospheric turbulence.
<b>Software-defined networking</b>	A programmable open-source approach that facilitates network management and enables programmatically efficient network configuration to improve network performance and monitoring. It is meant to address the fact that the static architecture of traditional networks is decentralized and complex, whereas current networks require more flexibility and easy troubleshooting.
<b>Spectrum optimization</b>	Optimizing the use of the radio frequency spectrum to promote efficient utilization and avoid and solve interference. Joint coordination of the transmit spectrum, i.e., transmission powers over all frequency carriers, of the interfering users so that the spectral efficiency is improved.

<b>Spectrum utilization</b>	The amount of information (measured in bits) being carried by a frequency spectrum. An appropriate theoretical measure for spectrum utilization is the average bits/m <sup>2</sup> or bits/Hz or bits/s. The maximum achievable rate of information per unit of spectrum depends on many factors, ranging from the physical propagation conditions to the state of technology and system design.
<b>Stability</b>	The ability of an electric power system, for a given initial operating condition, to maintain or regain a state of operating equilibrium after being subjected to a physical disturbance.
<b>Static synchronous compensator (STATCOM)</b>	A regulating device for AC transmission lines/systems that can produce (source) or absorb (sink) reactive power depending on the transmission system need.
<b>State estimation</b>	The act of estimating the state of the network from the redundant telemetry measurements.
<b>Storage</b>	The capture of energy produced at one time and stored for use later.
<b>Sustainable</b>	An energy system that serves the needs of the present without depleting and compromising the ability of future generations to meet their future energy needs.
<b>System protection</b>	A branch of electrical power engineering that deals with the protection of electrical power systems and their assets. Protection equipment includes relays, circuit breakers, reclosers, fuses, and other devices that protect the system from faults as well as provide the isolation of faulted parts from the rest of the electrical network. The objective of system protection is to keep the power system reliable, secure, and stable by isolating only those components that are faulted, while leaving as much of the network as possible still in operation.
<b>Thermal generation</b>	The process of generating electricity from heat produced from the combustion of fossil fuels or natural heat from geothermal activity. There are four thermal energy fuels: coal, natural gas, wood waste, and geo-thermal sources.
<b>Total harmonic distortion (THD)</b>	The sum of the all harmonic components in the system such as the total for current or voltage harmonics.
<b>Thermocouple</b>	An electrical device consisting of two dissimilar electrical conductors forming electrical junctions at differing temperatures. A thermocouple produces a temperature-dependent voltage as a result of the thermoelectric effect, and this voltage can be interpreted to measure temperature.
<b>Time synchronization</b>	Maintaining accurate time values on multiple devices located at some distance apart from each other. Time synchronization is realized by referring to a common and accurate time source, or multiple time sources with a small enough time differential to meet the synchronization requirement. In power system measurements, time-synchronized sensors receive time signals from a reliable and accurate time source, such as GPS, that can provide time traceable to a timing system, such as coordinated universal time or UTC, with sufficient accuracy to keep the measurement timestamps within the required limits.
<b>Time stamp</b>	A sequence of characters or encoded time information identifying when a certain event occurred, usually giving date and time of day but sometimes accurate to a small fraction of a second. The time stamp of sensor output represents the measured/recorded signal at the time it was applied to the sensor input.

<b>Transducer</b>	A device that converts energy from one form to another. Transducers are often employed in measurement, control, and power systems to convert electrical signals to and from other physical quantities (e.g., energy, force, torque, light, motion, position). In the case of power systems, a transducer converts high-voltage parameters on the transmission or distribution system into low-voltage parameters that are safe for sensors, measurement systems, and personnel.
<b>Transient dynamics</b>	Natural response of a dynamic system when it changes from one equilibrium state to another. Transient dynamics in electric power systems are usually caused by a major disturbance, such as a generation trip, load shedding, shunt capacitor switching, or short circuit. Transient dynamics usually include oscillations in the power system frequency and electromechanical wave propagation.
<b>Technology readiness level (TRL)</b>	The TRL is a method of estimating the technology maturity of equipment for real-world uses, such as critical technology elements of a program during the acquisition process.
<b>Unmanned aerial vehicle (UAV)</b>	A UAV, commonly known as a drone, is a small aircraft that is operated remotely by a human pilot.
<b>Use case</b>	An example case to illustrate how the method or approach works or might work.
<b>Variable renewables</b>	Resources such as wind and solar power that have variability and uncertainty in their electric energy provision due to variations in environmental conditions.
<b>Visibility</b>	The degree to which the operating states and asset conditions of a system are visible or observable to the system operator or engineer. The quality or fact of being visible or degree to which something is visible.

## APPENDIX B. CYBER-PHYSICAL SECURITY

The power system already uses multiple layers of sensors (e.g., electrical, mechanical, chemical), transducers (potential and current transformers), and actuators (e.g., breakers, capacitor banks, voltage regulators). The sensors detect, while actuators control the power flow, voltage level, and power quality from generation through the transmission/distribution system to end loads. Additionally, the roadmap document identifies a large variety of new sensor solutions through the work of national laboratory/industry working groups.

These sensors already must balance three non-orthogonal needs:

1. **Application requirements:** Requirements dictated by optimal resolution and accuracy needs to support decision-making frameworks at utilities.
2. **Integration requirements:** These are dictated by utility operational frameworks in procedures governing the deployment of new sensors into existing infrastructure with the least disruption to reliability, and their integration and interoperability with existing sensing and control infrastructures.
3. **Cost requirements:** Adoption of new technologies at cost-effective scale, particularly in legacy electric grid assets, drives the sensor cost requirements which vary at various levels of the grid infrastructure (e.g., monitoring transmission assets vs. distribution assets vs. end use).

Because of the increased importance of cybersecurity in power networks, sensors also need to add cyber-physical security awareness and support to their list of requirements to enable them to detect and mitigate complex cyber threats in the power grid.

Figure B.1 shows how the 5-tier control system architecture can be used to describe the interaction between the operational technology (OT) and information technology (IT) components of energy systems. Often, tiers 0–2 constitute the OT system and tiers 3–5 constitute the IT system. Although the OT system elements are frequently secured via an assortment of authentication, certificates and keys, and secure provisioning tools and practices, end users deal with the practical details of the OT-IT differentiation. As an example, consider Figure B.2, which illustrates ExxonMobil’s approach to OT-IT partitioning layered over the aforementioned 5-tier design structure. It is immediately apparent that the two facility operations have different areas of control but share the common value that cybersecurity of the information flow from layers 0 to 4, in the case of Figure B.2, must be maintained. New practices of bridging IT and OT networks or connecting OT devices to the internet have exposed the power system to new attack vectors.

Note specifically that cybersecurity network designs found in best practice documents such as NIST 800, and illustrated in Figures B.1 and B.2, have an overwhelming reliance on firewall segmentation between the networking layers. Firewalls are traditionally IT-system focused and are not invulnerable. OT-IT systems, on the other hand, require a unique set of defenses that accommodate their combined architecture. While firewalls are generally a good practice, current R&D is emphasizing a different approach with focused minimization of internet connectivity—even with device upgrades.

There is a need to build cybersecurity measures into the software code for the sensor microcontrollers’ VPN capability, thereby securing a transport tunnel into different layers of the overall framework. In addition, device authentication for a SCADA/distributed control system—validating the device via blockchain with the network, but not the actual information (measurement)—is being developed. Placing additional capabilities into the sensors-at-the-edge adds potentially increased cyber security.

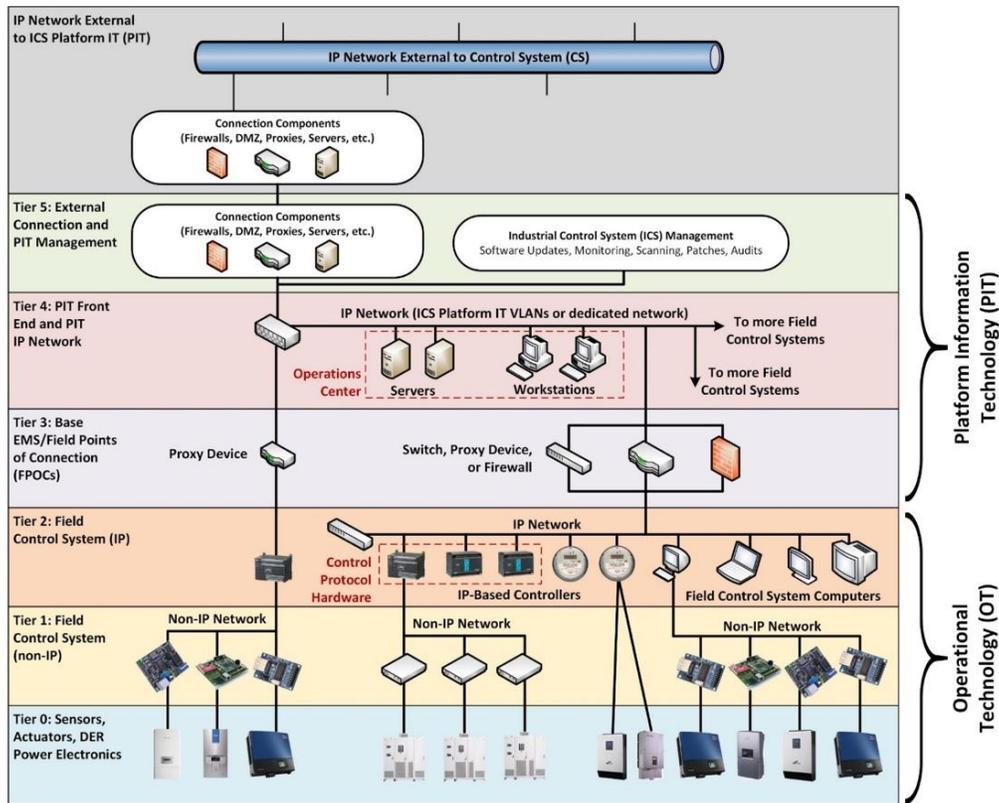

Figure B.1. Five-tier industrial control system (ICS) architecture.

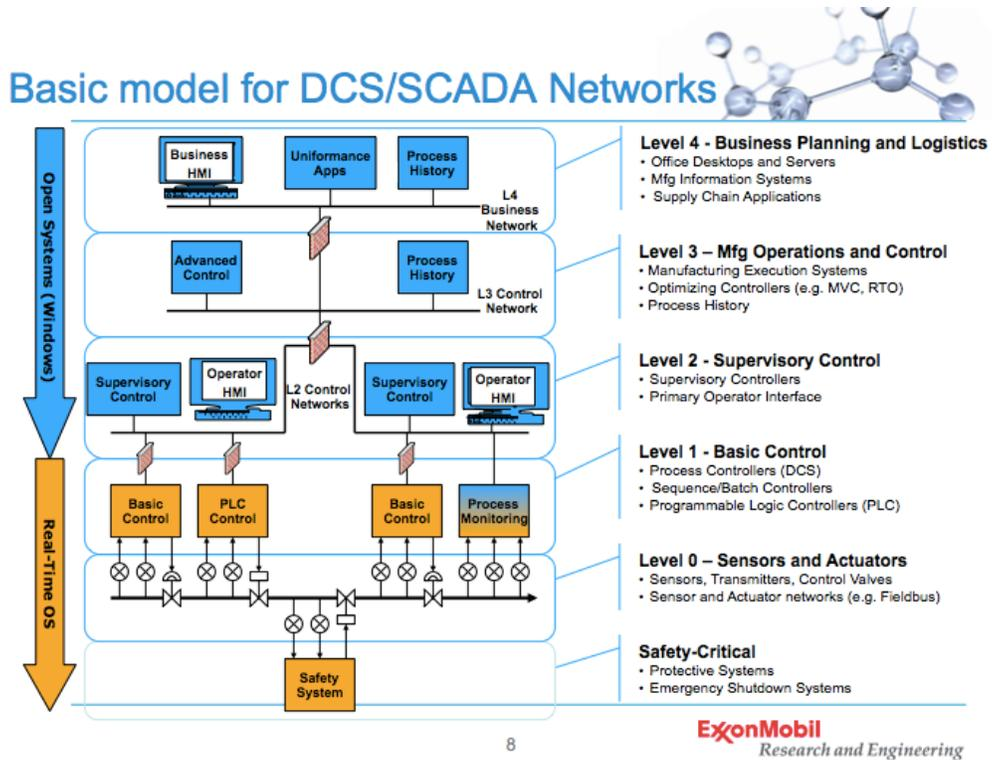

Figure B.2. ExxonMobil's system architecture illustrates a clear demarcation between OT and IT.

Sensors represent both an opportunity and a risk for power system cybersecurity. On the positive side, they are critical instruments for detecting and mitigating cybersecurity threats to power system infrastructure. Sensors designed to measure and analyze communication systems are useful for intrusion detection and intrusion prevention system. These tools can alert IT or OT network operators to adversarial actions or reconnaissance by hackers. For instance, firewalls can log all traffic from external IP addresses and warn or block traffic when specific protocols are used. Similarly, data analytics can be used to compare power system measurements with network communications; for example, a relay may report that it is closed while the downstream voltage is reading zero, which indicates that it is open. The fact that this information is inconsistent could indicate that the relay or voltage sensor or both were involved in a spoofing attack.

Unfortunately, sensors are also vulnerable to cyber attacks, including spoofing, denial of service, and man-in-the-middle. For example, in the scenario mentioned in the previous paragraph, the potential transformer might actually be the sensor device providing the manipulated (voltage) data. Often, sensor communications are simple serial or other unroutable (layer 2) protocols that are unencrypted until they reach measurement, analyzing, or processing equipment that has more computing capability (tier 2 in Figure B.1). At any point in this data gathering or transfer, a cyber attack could occur and corrupt the data. The sensor measurements could be manipulated or falsified through various transduction cyberattacks, e.g., ultrasonic proximity sensors<sup>26</sup>; the low-level sensor measurements, e.g., 0–10 V signal, could be physically or remotely modified before reaching the measurement and processing equipment; or the processed or measured data could be changed either at the data concentrator or when reported back to the industrial control system/plant information system. Each of these attack modes should be considered for robust, cyber-secure sensor deployment.

Additional hardware-based cybersecurity approaches exist and are in various stages of research. Resource-constrained devices, such as sensors and sensing applications, are vulnerable to invasive attacks that are designed to steal keys stored in nonvolatile memory (NVM), and NVM adds cost to these low-cost devices. A physical unclonable function (PUFs)<sup>27</sup> is a novel hardware security mechanism that provides an alternative key storage mechanism that does not require NVM but rather derives the key from small analog variations that exist from one copy of a chip to another. Therefore, the key, which is not stored in digital form anywhere, is derived on the fly as needed and is tamper-evident; i.e., any attempt to steal the secret destroys the PUF and the ability of the chip to regenerate it. Moreover, a special class of PUFs, called “strong PUFs,” are able to generate an exponential number of reproducible secret bits that can be used to harden security protocols further. Moreover, strong PUFs can also reduce area and energy overheads by reducing the number and type of cryptographic primitives and operations.

There is a bewildering array of cybersecurity threat and attack scenarios that may be associated with the various layers in a SCADA/digital control system realm. Numerous associations of end users, vendors, academics, and so on are involved with examining such scenarios. Within DOE, the Cybersecurity for Energy Delivery Systems (CEDS) program’s Roadmap for Cybersecurity provides a robust intersection with GMLC sensing and measurement strategy project activities. Individuals interested in examining CEDS-sponsored projects may wish to visit the CEDS website at <https://energy.gov/oe/cybersecurity-energy-delivery-systems-ceds-fact-sheets>, where individual fact sheets are available.

---

<sup>26</sup> <https://securityledger.com/2018/01/researchers-warn-physics-based-attacks-sensors/>

<sup>27</sup> Wenjie Che, Mitchell Martin, Goutham Pocklassery, Venkata K. Kajuluri, Fareena Saqib, and Jim Plusquellic. “A privacy-preserving, mutual PUF-based authentication protocol.” *Cryptography* 1, no. 1 (2016): 3.



## APPENDIX C. SENSOR AND MEASUREMENT TECHNOLOGY ROADMAP PROCESS

The Grid Modernization and Lab Consortium Sensing and Measurement Strategy project’s Technology Roadmap document has been developed as a collaboration across the DOE national laboratory system in close partnership with key partners and stakeholders from industry, academia, and other relevant government organizations. A list of the participating stakeholder partners can be found in the body of the report, and a detailed list of participating individuals and their organizations and individuals is found in Appendix D.

The Sensing and Measurement Roadmap effort has been carried out as an iterative process that summarizes the current state of the art, outlines existing gaps, and points toward areas of potential need and opportunity for federal investment to make a significant impact. A graphical illustration of the overall technology roadmap development effort is presented in Figure C.1. In addition to the work represented in this graphic, additional efforts continued into calendar year 2018, including review and input by NIST collaborators, additional revisions by working group leads and the PI/task lead based upon input from industry stakeholders, and finally refinement by the PI/task lead prior to full publication.

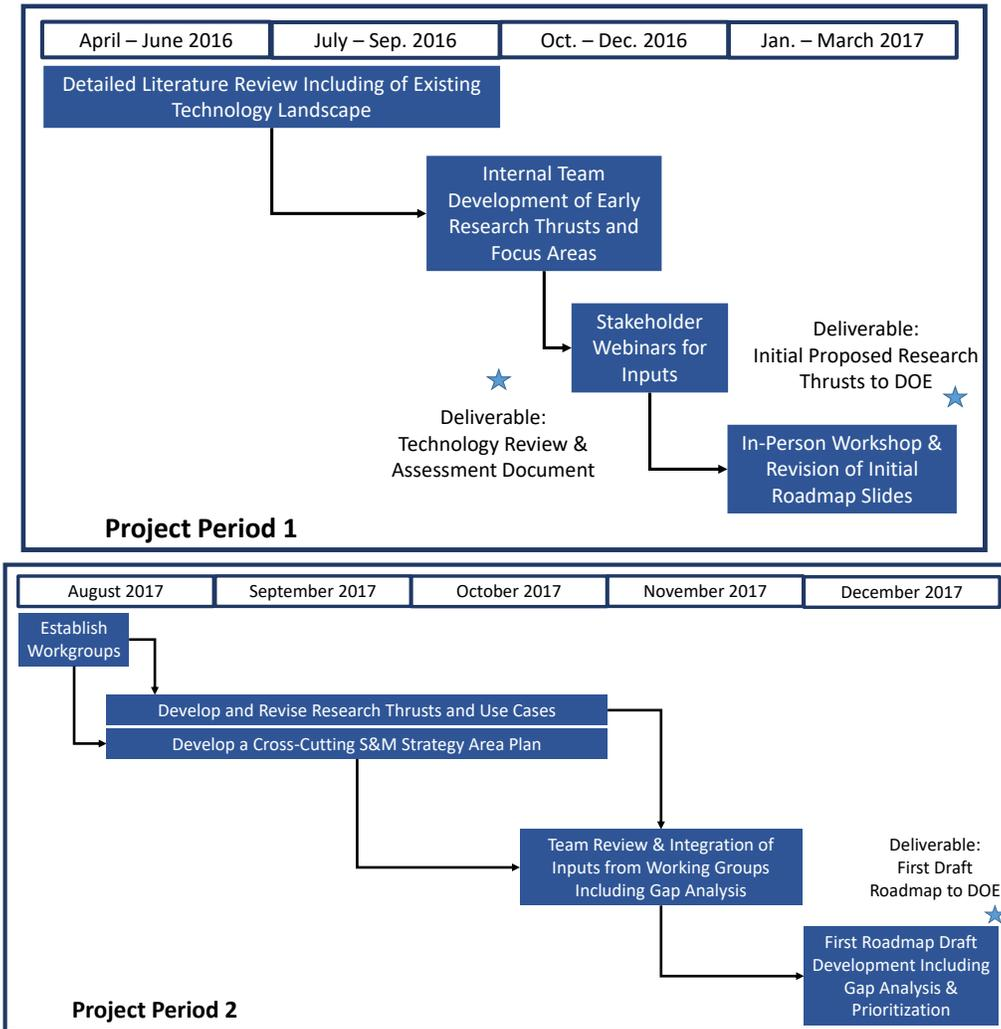

Figure C.1. Technology roadmap development process and timeline.

The first phase of the roadmap process began in September of 2016 with the development of an extended literature review by the national laboratory team on the topic of the state of the art in sensing and measurement devices, communication, and data management and analytics technologies as they relate to the extended grid state of the power system spanning generation, transmission, distribution and end use.<sup>28</sup> The result of this effort was a Technology Review and Assessment document, which contains information on previous roadmaps, technical literature, program documents, and other resources that were used for the road mapping effort. Based upon some initial identified needs and trends for new sensing and measurement technologies within the extended power system resulting from this first stage of the effort, the laboratory team identified an initial set of recommendations for technology gaps and suggested an initial set of research thrusts and an approach to organizing the Technology Roadmap (which leveraged the EPRI Transmission and Substation Technology Roadmap format).<sup>29</sup> A first draft of the Technology roadmap without detailed gap analysis or prioritization was presented to stakeholders in a public workshop held at and hosted by ComEd in February of 2017 to garner initial stakeholder feedback to inform the path forward. A revised draft of the technology roadmap slides was provided to DOE program managers for review and input in April of 2017.

The second phase of the technology roadmap process began in August 2017 with the goals of (1) improving the integration of the extended grid state definition with the technology roadmap; (2) engaging with stakeholders to refine the proposed research thrusts and perform a detailed gap analysis, including the development of quantitative metrics; and (3) developing a set of specific, actionable recommendations for federal initiatives that could advance the objectives of the Grid Modernization Initiative. The Sensing and Measurement team established several working groups to coordinate accomplishment of each of these primary objectives (see further details in Appendix D):

1. Crosscutting Sensing and Measurement Support
2. Use Case Refinement and Extended Grid State Integration
3. Harsh Environment Sensors for Flexible Generation
4. Phasor Measurement Units for Grid State and Power Flow
5. Asset Health Monitoring
6. Novel Transducers
7. Sensors for Weather Monitoring and Forecasting
8. End-Use/Buildings Monitoring
9. Distributed Architectures
10. Communications Technology
11. Advanced Analytics
12. Big Data

Each of these working groups operated independently with oversight and coordination by the GMLC Sensing and Measurement Strategy project PI (Tom Rizy) and roadmapping (Task 2) lead (Paul Ohodnicki). Each working group developed metrics (quantitative where possible) and a detailed gap analysis to clarify where additional technologies, tools and techniques are needed to enable better visibility, understanding, and operating and control capabilities for the complex future modern power system and to help guide future targeted R&D efforts. The working groups also worked with national laboratory staff and industry stakeholders to better understand the current state of the art within each technical area (reflected in the Technology Review and Assessment document) and developed

---

<sup>28</sup> *Review and Assessment of Sensing and Measurement Technology for Electric Grids, Devices Including Communications and Data Analytics Requirements*, ORNL/SPR-2018/956, December 2018, prepared by the GMLC Sensing & Measurement Strategy Project (PI: D. Tom Rizy, Task Lead: Paul Ohodnicki) and posted on the GMLC website at <https://gridmod.labworks.org/resources>.

<sup>29</sup> EPRI Transmission and Substation Technology Roadmap.

recommendations for a coherent Sensing and Measurement strategy for the Grid Modernization Initiative. Those elements are reflected in this Roadmap.



## **APPENDIX D. WORKING GROUP REPORT SUMMARIES**

### **D.1 CROSSCUTTING NEEDS TO SUPPORT SUCCESS OF THE SENSING AND MEASUREMENT STRATEGY (LABORATORY LEAD: ZHI LI, ORNL)**

#### **D.1.1 Scope of Working Group**

A need exists for foundational efforts to support the successful technology development and deployment of advanced sensing and measurement tools and methodologies throughout the electrical grid infrastructure. This crosscutting effort will span the various research thrusts and initiatives outlined in more detail in subsequent sections of the technology roadmap document.

The objective of this crosscutting effort is to raise awareness of the identified issues that are common across different sensing and measurement areas, create a gateway for stakeholders to efficiently access the right expertise and resources to address the issues, and provide support, technical or nontechnical, necessary to facilitate those efforts.

The crosscutting support area was not in the original scope of the Sensing and Measurement Technology Roadmap. It was initiated based on comments the project team received after the project's stakeholder review meeting held in February 2017. Four preliminary crosscutting support initiatives were proposed by the project team first. Based on the results of reviews and discussions, the crosscutting working group then expanded them into six initiatives:

1. Cyber-physical security awareness and support
2. Data quality and utilization improvement
3. Sensor performance, reliability, resiliency testing, and calibration methodologies
4. Standards and interoperability requirements for deployment of advanced sensors
5. Support for sensing and measurement technology promotion and deployment
6. General crosscutting needs support for industry and utility partners

This working group is to review and critique the six crosscutting initiatives, help the project team develop a detailed scope and tasks for each initiative, and clarify the structure of the crosscutting sensing and measurement support area in terms of the organizational framework and interface with existing GMLC projects.

#### **D.1.2 Working Group Process**

The Crosscutting Needs Working Group established a core group of stakeholders spanning the DOE national laboratory system, academia, federal power operating and research agencies, and vendors. The following table shows a full list of participants.

Name	Organization	Contact information
Scott Averitt	Bosch	<a href="mailto:Scott.Averitt@us.bosch.com">Scott.Averitt@us.bosch.com</a>
Kang Lee	NIST	<a href="mailto:kang.lee@nist.gov">kang.lee@nist.gov</a>
Eugene Song	NIST	<a href="mailto:eugene.song@nist.gov">eugene.song@nist.gov</a>
Gordon Mathews	NASPI Distribution Task Team/Bonneville Power Administration	<a href="mailto:ghmatthews@bpa.gov">ghmatthews@bpa.gov</a>
Sudipta Chakraborty	Opal-RT	<a href="mailto:Sudipta.Chakraborty@opal-rt.com">Sudipta.Chakraborty@opal-rt.com</a>
Venkat Shastri	NASPI Distribution Task Team/University of San Diego	<a href="mailto:venkat@saniego.edu">venkat@saniego.edu</a>
Zhi Li	ORNL	<a href="mailto:liz2@ornl.gov">liz2@ornl.gov</a>
Tom Rizy	ORNL	<a href="mailto:dtom@ornl.gov">dtom@ornl.gov</a>
Chen	ANL	<a href="mailto:morningchen@anl.gov">morningchen@anl.gov</a>

The team was first asked to review the four preliminary crosscutting initiatives and comment on whether they fit in the scope of the roadmap. The working group was also asked to provide ideas on any other crosscutting initiatives that needed to be included in this focus area. After several rounds of reviews and analyses, the scope of the four original initiatives was adjusted and clarified, and two new initiatives were identified according to input from the team members. The team then discussed and refined the task details of the six initiatives. Some gaps in the crosscutting areas were identified and discussed. Based on the results of all these discussions, the roadmap input for the crosscutting focus area was updated, and the gap analysis was conducted in the context of existing GMLC efforts.

Finally, according to the comments received during the second industry review meeting held in Atlanta, Georgia, in April 2018, the six initiatives were condensed into four. The “data quality and utilization improvement” initiative (Initiative 2) was removed from this crosscutting focus area, and its contents were integrated into the Data Analytics and Management focus areas. The sensor testing and standards initiatives (Initiatives 3 and 4) were combined into one because of the inherent correlations between the two topics. With these adjustments, four initiatives are recommended as the final output of the work by this crosscutting working group.

### D.1.3 Key Findings and Recommendations

As finalized by the working group, the four recommended crosscutting initiatives are

1. Cyber-physical security awareness and support
2. Standards and testing to support improvement of sensor performance, reliability, resiliency, and interoperability
3. Valuation of sensing and measurement technology
4. General crosscutting needs support for industry and utility partners in technology deployment

Initiatives 1–3 focus on technical issues common across all types of sensing and measurement technologies covered in the report. Initiative 4 is designed to be a long-standing venue to support industry and utility partners with general crosscutting needs, even after the activities of the other initiatives have been closed. The approaches for these initiatives can be summarized as reviewing and documenting existing knowledge; harmonizing existing requirements and standards; developing new definitions, standards, and tools/methods; and providing guidance and support. Some of the proposed development and analysis work can possibly be developed into future stand-alone projects (under GMLC or other

funding support). Some can be related to or tied in with existing GMLC projects, the results and findings of which can be readily used to address the crosscutting issues. It is also possible for some of the proposed crosscutting activities to be merged or coordinated with the existing efforts.

#### D.1.4 Gap Analysis Summary

Gaps identified by the working group	Relevant crosscutting initiative	Approach to address gap
Low awareness level of cyber-physical security of sensing and measurement systems	Initiative 1	Raise awareness of the cyber-physical security of sensor systems by providing accurate information, expertise, and communication channels to the stakeholders
Lack of comprehensive research dedicated to cyber-physical issues of sensing and measurement systems.	Initiative 1	Analyze the security challenges and gaps in existing sensor infrastructure. Summarize the cyber-physical requirements for sensor systems used in power grid applications
Lack of definition of sensor resiliency and resiliency testing requirements.	Initiative 2	Define standardized definitions, methodologies, and practices for benchmarking and testing of sensor performance, reliability, and resiliency
Nonstandardized testing procedures and discrepancies in existing testing standards	Initiative 2	Harmonize existing testing standards to eliminate discrepancies
Complications in identifying applicable standards, interoperability requirements, and testing facilities for emerging sensor technology	Initiative 2	Maintain an up-to-date understanding of standards and testing facilities that have comprehensive capabilities Develop strategic partnerships with private- and public-sector partners to enable access to relevant testing facilities
Insufficient mechanisms to accommodate emerging sensor technologies in development of new standards	Initiative 2	Provide technical input into new standards through active participation and engagement Develop sensor-specific working groups and consortiums for measurement quality assurance and format standardization for utility integration
Lack of comprehensive capabilities and sophisticated tools to conduct valid technology valuation and regulatory analysis for promotion emerging sensor technologies	Initiative 3	Identify and categorize relevant capabilities and tools (e.g., regulatory analysis, technology valuation) across the DOE national laboratory system and maintain up-to-date contact information. Establish two-way communication between regulation makers and stakeholders to help accelerate technology adoption and deployment
Needs for long-term and continuous efforts to support the industry and utility partners in some general crosscutting issues	Initiative 4	Hold regular workshops with industry and utility partners to maintain a working knowledge of barriers preventing new sensing and measurement technology deployment. Lessons learned and needs for new

Gaps identified by the working group	Relevant crosscutting initiative	Approach to address gap
		expertise and facilities will be communicated with DOE and GMLC leadership to identify opportunities where technical resources within the DOE system can be leveraged to provide assistance

For future reference and to show the process of the work done by the working group, details of the gap analysis based on the original six initiatives (before they were condensed into the four recommended ones) are provided below:

#### **D.1.4.1 Cyber-Physical Security Awareness and Support**

Sensing and measurement systems in the power grid are in the front lines of the battle against cyber-physical threats. However, awareness of the cyber-physical security issues of the sensing and measurement systems still, in some sense, remains at qualitative levels. It lacks in-depth understanding of challenges and technical details that are specific to sensing and measurement devices. The great diversity of the sensors used in the power grid makes it more difficult to address the issues. Some sensors may have built-in cyber-physical security measures. However, many sensors operating in the power grid that contain numerous components may complicate the threats and require more careful considerations and solutions. Therefore, there is room for a top-down, comprehensive research effort on the cyber-physical security of the power grid’s sensing and measurement systems.

This crosscutting initiative is to raise awareness of the cyber-physical security of the sensor and measurement systems in the power grid by developing more technically oriented guidance and reference. Analysis of the security challenges and gaps for existing sensor infrastructure will be conducted. Comprehensive cyber-physical requirements for sensor systems used in power grid applications will be summarized and documented. The initiative will also provide support to stakeholders (mostly the corresponding researchers, sensing technology developers/vendors, and sensor system users) in improving the security of existing sensor and measurement infrastructure and developing new sensor projects with built-in reinforcement of cyber-physical security. It will facilitate the communication channels to bring the right expertise and resources to the stakeholders to address the cyber-physical vulnerabilities regarding sensor and measurement applications in the power grid.

GMLC Project 1.4.23, Threat Detection and Response with Data Analytics: This related project is to develop advanced analytics on operational cyber data to detect complex cyber threats in the power grid. The outcomes will help power operators differentiate between cyber and non-cyber-caused incidents like physical attacks or natural hazards. It may provide a tool to support the cyber-physical security needs discussed in this crosscutting initiative.

#### **D.1.4.2 Data Quality and Utilization Improvement**

Data conditioning is an integral part of sensing and measurement processes that are common for every type of sensing technology. But its importance could be underestimated in many applications, especially those in harsh environments. Poor data quality and availability could diminish the usability and efficiency of a sensing and measurement system and even cause the failure of a sensor project. Improved understanding of the data quality issues and updated knowledge of state-of-the-art data processing

approaches are necessities for stakeholders and help the promotion of advanced data management technologies to achieve better utilization of data.

This crosscutting initiative will provide a knowledge set of data quality-related topics and technologies to help utilities and other industry partners address the challenges on the downstream side of sensing and measurement caused by poor data quality and availability. It will also provide support to utilities in adopting advanced data management technologies and improving data utilization. Proposed activities include understanding data quality issues related to sensor and measurement systems, especially those working in harsh environments or having restricted requirements for data quality; summarizing the state of the art of data processing and modeling approaches to improve sensor and measurement system performance; and hosting workshops or training sessions to promote advanced data management technologies.

#### **D.1.4.3 Sensor Performance, Reliability, Resiliency Testing, and Calibration Methodologies**

Resiliency has become a key factor to be considered in the design of power grid components, including sensors. As a result, testing of resiliency is drawing more and more attention from the R&D community. However, big gaps exist in resiliency testing of sensors, from the definition of sensor resiliency to standardized testing requirements and methodologies, as well as appropriate testing facilities for evaluating sensor resiliency. In addition, there are discrepancies in existing testing standards and procedures for testing of sensor performance and reliability.

This crosscutting initiative will target the establishment of standardized methodologies and procedures for benchmarking and testing functional performance, reliability, and resiliency (in the presence of extreme natural or man-made events) of sensors before engaging in the full deployment phase. It will also promote the establishment of a database of testing facilities with comprehensive capabilities in regular performance and reliability tests as well as resiliency tests. To achieve the goals, standardized testing requirements for sensor resiliency and methodologies and practices for benchmarking and testing of sensor performance, reliability, and resiliency will be defined. Harmonization of existing testing standards to eliminate discrepancies will be conducted. Testing facilities with comprehensive capabilities, especially in intrusive testing to address resiliency, will be reviewed. Finally, strategic partnerships will be established with private and public-sector partners to enable access to relevant testing facilities.

GMLC Project 1.2.3, Grid Modernization Laboratory Consortium Testing Network: This related GMLC project is to close the gap in accessibility to validated models for grid devices and simulation tools and the corresponding full documentation. It will drive standardization and adoption of best practices related to device characterization, model validation, and simulation capabilities through facilitated industry engagement. Some of the findings may help address the testing issues brought up in this crosscutting initiative.

#### **D.1.4.4 Standards and Interoperability Requirements for Deployment of Advanced Sensors**

The types of sensors used in the power grid and their communication setups vary significantly based on applications. That causes complications in identifying the appropriate standards and interoperability requirements. The sensing and measurement technologies, and their deployment, should be compliant, especially for emerging technologies and advanced sensors. On the other hand, the developers of new standards and interoperability requirements should be aware of the emerging technologies and trends. Unfortunately, existing tools and/or mechanisms to address both of these issues are insufficient.

This crosscutting initiative will interface with relevant standards organizations to ensure that sensor development and deployment efforts under the GMLC are consistent with applicable existing and

emerging standards and requirements. This initiative will also seek to provide technical input into the development of future and emerging standards and interoperability requirements. An up-to-date understanding of standards and interoperability requirements specific to sensing and measurement technology for the electrical grid infrastructure will be maintained. Technical input will be provided for the development of new standards through active participation and engagement.

Within GMLC, several ongoing projects have been identified as being related to this initiative. The following are three of these projects with brief descriptions.

- GMLC Project 1.2.2, Interoperability: Will articulate general interoperability requirements, along with methodologies and tools for simplifying integration and cyber-secure interaction among the various devices and systems by establishing a strategic vision for interoperability, measuring the state of interoperability in technical domains, identifying gaps and roadmaps, and ensuring industry engagement.
- GMLC Project 1.4.1, Standards and Test Procedures for Interconnection and Interoperability: Will help develop and validate interconnection and interoperability standards for existing and new electrical generation, storage, and loads that ensures cross technology compatibility, ensures harmonization of jurisdictional requirements, and ultimately enables high deployment levels without compromising grid reliability, safety, or security.
- GMLC Project SI-1695, Accelerating Systems Integration Codes and Standards: Will update the standards identified under the grid performance and reliability topic area, focusing on the distribution grid. Establishing accelerated development of new interconnection and interoperability requirements and conformance procedures is the key result for this project.

#### **D.1.4.5 Support for Sensing and Measurement Technology Deployment**

Valid and accurate valuation and risk/uncertainty analysis are among the defining tools utilities need to adopt emerging technologies, including those for sensing and measurement in the power grid. Technology valuation usually involves extensive analysis and quantitative modeling of technical and economic risks and benefits. A lack of comprehensive capabilities and sophisticated tools to conduct valid technology valuation is one of the major barriers for promotion of a new technology. In addition, regulatory activity may play a leveraging role that could significantly affect technology adoption and deployment and make the analysis more complicated. Regulatory incentives encourage the adoption of new technologies, whereas regulatory restrictions may induce extra costs and discourage the adoption.

This crosscutting initiative is to support the clearing of obstacles to the adoption and deployment of emerging sensing and measurement technologies throughout the modern electrical grid infrastructure, with an emphasis on regulatory and economic concerns. It will promote the establishment of expertise and capabilities both internal and external to the DOE national laboratory system to facilitate regulatory analysis, risk evaluation, and technology valuation for sensor deployment projects. Relevant capabilities and tools (e.g., regulatory analysis, technology valuation) will be identified and categorized with up-to-date contact information. Two-way communication between regulation makers and stakeholders will be established to help resolve misunderstandings and inconsistencies to accelerate technology adoption and deployment.

Some ongoing projects within GMLC are related to the topic of this initiative, and the findings and results of those projects might be worth consideration for the proposed work of this initiative. GMLC Project 1.2.4 and 1.4.29 are two examples.

- **GMLC Project 1.2.4, Grid Services and Technologies Valuation Framework:** This project is to address the inconsistencies and lack of transparency across existing valuation methodologies by developing a comprehensive and transparent framework to value the services and impacts of grid-related technologies. The valuation framework may be useful to assess “regulated investments,” as well as investments by private sector entities. The proposed framework might be used for sensing and measurement technologies.
- **GMLC Project 1.4.29, Future Electricity Utility Regulation:** This project assists states in addressing regulatory, ratemaking, financial, business model, and market issues related to grid modernization in the power sector. It will also help tie utility earnings to consumer value, economic efficiency, and other public policy goals. Some findings of the project may directly benefit this crosscutting initiative. The findings could provide insight into issues like how to adapt electric utility regulation and ratemaking to new technologies and services, assess potential financial impacts on utility shareholders and customers, consider investments required in infrastructure to enable customer engagement, and provide incentives to utilities to achieve grid modernization goals.

#### **D.1.4.6 General Crosscutting Needs Support for Industry and Utility Partners**

Most of the proposed work of the five crosscutting initiatives can be addressed by one-time or short-term endeavors. However, after all those activities are accomplished, there still will be a need for long-term and continuous efforts to support the industry and utility partners in some general crosscutting issues. Examples may include continuous updating of contact information, expertise lists, technology databases, and support for recurring events (e.g., workshop). In addition, some new crosscutting needs, such as expertise matchmaking, may arise on a project-by-project basis. Therefore, having a standing mechanism, which is missing in the current setup, to support those needs will be necessary and beneficial in the long run. This initiative is proposed to address those considerations.

This initiative is to provide a long-standing mechanism to support industry and utility partners in general crosscutting needs. It will promote the establishment of relationships and partnerships among research, industry, utility, and regulation communities. It provides a standing venue for stakeholders to voice the challenges they face in the development and deployment of new sensing and measurement technologies within their systems. Regular workshops will be held with industry and utility partners to maintain a working knowledge of barriers preventing new sensing and measurement technology deployment. Lessons learned and needs for new expertise and facilities will be communicated with DOE and GMLC leadership to identify opportunities where technical resources within the DOE system can be leveraged to provide assistance.

## **D.2 HARSH ENVIRONMENT SENSORS FOR FLEXIBLE GENERATION (LABORATORY LEAD: SYDNI CREDLE, NETL)**

### **D.2.1 Scope of Working Group**

Flexible operation of conventional power plants refers to the potential of fossil and nuclear energy to serve applications other than their traditional baseload operations as part of the grid modernization strategy. In addition to baseload and spinning reserve, power plants can provide additional services through flexible operation. Enhanced capabilities for internal monitoring of power generation processes in real time enables advanced control strategies and designs of conventional plants to reduce any potentially adverse impacts on the generators, and they encourage more rapid adoption of newer technologies compatible with energy efficient and flexible operation. This working group will review the current proposed research thrusts within this focus area of the Roadmap and will develop a clear understanding of

the current industrial state of the art and quantitative metrics for new sensing and measurement technology development.

### D.2.2 Working Group Process

The Harsh Environment working group is composed of key stakeholders from the DOE Office of Fossil Energy’s NETL and INL. NETL has a long-standing active Sensors and Controls program that specializes in advanced concepts and technology innovation relevant to harsh environments observed in advanced energy systems. INL has been engaged for many years in the development of advanced nuclear instrumentation in support of nuclear fuels and materials test in the Advanced Test Reactor and other irradiation facilities part of the National Science User Facilities program. The following is a full list of participants.

Name	Organization	Contact information
Sydni Credle	NETL	<a href="mailto:Sydni.Credle@netl.doe.gov">Sydni.Credle@netl.doe.gov</a>
Paul Ohodnicki	NETL	<a href="mailto:Paul.Ohodnicki@netl.doe.gov">Paul.Ohodnicki@netl.doe.gov</a>
Benjamin Chorpening	NETL	<a href="mailto:Benjamin.Chorpening@netl.doe.gov">Benjamin.Chorpening@netl.doe.gov</a>
Patrick Calderoni	INL	<a href="mailto:patrick.calderoni@inl.gov">patrick.calderoni@inl.gov</a>

### D.2.3 Key Findings and Recommendations

The gap analysis summary table in Section D.2.5 presents a summary of the key findings from the working group, including gaps identified by the working group, approaches to address the gaps, and key metrics that formulate the basis for evaluation. Key findings include the following:

- Survivability and durability are of critical importance for harsh environment sensing. ***Federal research is needed in advanced materials development, packaging methodologies, and advanced manufacturing processes to enable robust, reliable, and durable performance within challenging operational environments*** that may feature high-temperature (700–1800°C), high-pressure (up to ~10<sup>7</sup>Pa), erosive, and/or corrosive environments and radiation exposure.
- The ability to co-locate sensing elements with periphery electronics, such as capacitors, resistors, signal conditioning amplifiers, transmitters, and so on, in close proximity to the harsh service environments is very advantageous. ***Federal research in the area of high-temperature and radiation-hardened electronics is needed to reduce sensor node interfaces, lower system complexity, improve deployment functionality, and realize overall improvement of operational measurements.***
- Multipoint, distributed measurements allow for higher-fidelity monitoring capability that produces broader insight into the status as well as the condition of power generation assets than stand-alone single-point measurements can supply. ***Federal research related to implementation of robust sensing networks and/or arrays with multiple sensor nodes—including data fusion techniques that combine, filter, and process numerous data streams under high-temperature, challenging thermal and mechanical loads, radiation exposure, electrical noise, and other parameter excursions—is essential to the future viability of flexible power generation.*** Additionally, the development of data standards and communications protocols within the context of power generation allows for optimized implementation of distributed sensor networks.

4. Sensor nodes for harsh environments have a wide variety of constraints that may prevent sustained power supply to them. In many cases, nodes are remotely located; have limited accessibility; and require long durations between component lifetimes, maintenance intervals, or specified replacement periods. *Federal research is needed to investigate novel approaches, such as energy harvesting and other techniques (e.g., wireless power transfer), to powering sensors for continuous operation.*
5. *Federal research is needed to advance the current state of the art in diagnostic techniques that encompass the ruggedization of laboratory techniques as well as advanced tools and devices that can effectively evaluate sensor systems while operating under harsh environment conditions.*

#### D.2.4 Proposed Research Thrusts and Prioritization

Based upon the results of the working group efforts and the associated gap analysis (shown in the table below), a total of two different research thrusts have been recommended for prioritization. A detailed description of the research thrusts is presented in the context of all research thrusts for the GMLC initiative.

The research thrusts recommended are

1. Harsh environment sensing for real-time monitoring (recommended)
2. Advanced electromagnetic diagnostic techniques (recommended)

#### D.2.5 Gap Analysis Summary

Gaps identified by working group	Relevant research thrust or thrusts	Approach to address gap	Key metrics to be addressed
Advanced materials development for sensing elements	Research thrust 1: Harsh environment sensing for real-time monitoring	Propose advanced materials science and engineering techniques to develop novel sensing materials capable of deployment in harsh environments	Component-specific performance, high-temperature compatibility, stability (under neutron and other ionizing radiation), and cost
Robust packaging technologies to ensure reliable, durable performance	Research thrust 1: Harsh environment sensing for real-time monitoring	Develop new sensor packaging materials capable of withstanding high-temperature, high-pressure environments	Component-specific performance, cost, maximum temperature, thermal properties (shock resistance, expansion), compatibility with sensor materials, low activation in radiation environment, mechanical durability during installation or incidental contact during plant maintenance
High-temperature electronics	Research thrust 1: Harsh environment sensing for real-time monitoring Research thrust 2: Advanced electromagnetic diagnostic techniques	Develop electronic devices and circuits capable of high-temperature operation while maintaining low costs	Performance (including radiation hardness) and cost

Gaps identified by working group	Relevant research thrust or thrusts	Approach to address gap	Key metrics to be addressed
Advanced manufacturing	Research thrust 1: Harsh environment sensing for real-time monitoring	Development of novel manufacturing and fabrication processes that enable novel concepts, such as embedded sensing and other novel multi-functional designs	Component-specific performance
Multi-point, Distributed sensing	Research thrust 1: Harsh environment sensing for real-time monitoring  Research thrust 2: Advanced electromagnetic diagnostic techniques	Development of multipoint techniques that enable distributed measurements with optimal spatial resolution for power generation components while maintaining low costs	Number of sensor nodes, spatial resolution, performance (including degradation under irradiation), and cost
Realizing power requirements for sensor nodes	Research thrust 1: Harsh environment sensing for real-time monitoring	Develop novel approaches, including advanced methods such as energy harvesting, to satisfy power requirements in sensor nodes	Sensor node energy requirements and energy availability from operational environment
Standardized data and communication protocols	Research thrust 1: Harsh environment sensing for real-time monitoring	More clearly communicate the challenges associated with using new sensor data as barriers to deployment and implementation	Standards efficacy, awareness by standards organizations
Data fusion technologies	Research thrust 1: Harsh environment sensing for real-time monitoring Research thrust 2: Advanced electromagnetic diagnostic techniques	Apply advanced data fusion methodologies to sensing in harsh environments to support distributed, multipoint sensing	Measurement accuracy, spatial resolution, and reduced interference effects
Diagnostic techniques	Research thrust 2: Advanced electromagnetic diagnostic techniques	Development of advanced tools that can effectively evaluate sensor systems while operating in harsh environments. Ruggedization of laboratory techniques to make them applicable in field service and/or commercial applications	Measurement accuracy, reliability, performance (including degradation under irradiation), and cost

### D.3 ASSET HEALTH MONITORING (LABORATORY LEAD: PAUL OHODNICKI, NETL)

#### D.3.1 Scope of Working Group

Asset monitoring for determining the health condition of various items of equipment in the power system can potentially be applied to all assets within the electrical power system, including generators, energy

storage, loads, lines, and power conditioning components. The goal is to determine if the asset is nearing the time for maintenance, nearing failure, or nearing end of life. This working group will review the current proposed research thrusts within this focus area of the Sensing and Measurement Technology Roadmap and will develop a clear understanding of the current industrial state of the art and quantitative metrics for new sensing and measurement technology development.

### D.3.2 Working Group Process

The Asset Health Monitoring working group established a core group of stakeholders spanning the DOE national laboratory system, academia, utilities, and vendors. The following is a full list of participants.

Name	Organization	Contact information
Paul Ohodnicki	NETL	<a href="mailto:paul.ohodnicki@netl.doe.gov">paul.ohodnicki@netl.doe.gov</a>
Alireza Shahsavari	NASPI Distribution Task Team/University CA–Riverside	<a href="mailto:ashah023@ucr.edu">ashah023@ucr.edu</a>
Gordon Mathews	NASPI Distribution Task Team/Bonneville Power Administration	<a href="mailto:ghmathews@bpa.gov">ghmathews@bpa.gov</a>
Jim Glass	Electric Power Board of Chattanooga	<a href="mailto:glassjb@epb.net">glassjb@epb.net</a>
Lilian Bruce	Electric Power Board of Chattanooga	<a href="mailto:brucelb@epb.net">brucelb@epb.net</a>
Stephan Amsbary	EPRI	<a href="mailto:samsbary@epri.com">samsbary@epri.com</a>
Sarma (NDR) Nuthalapati	PEAK	<a href="mailto:snuthalapati@peakrc.com">snuthalapati@peakrc.com</a>
Scott Averitt	Bosch	<a href="mailto:Scott.Averitt@us.bosch.com">Scott.Averitt@us.bosch.com</a>
Venkat Shastri	NASPI Distribution Task Team/University of San Diego	<a href="mailto:venkat@sandiego.edu">venkat@sandiego.edu</a>
Olga Lavrova	SNL	<a href="mailto:olavrov@sandia.gov">olavrov@sandia.gov</a>
Kofi Korsah	ORNL	<a href="mailto:korsahk@ornl.gov">korsahk@ornl.gov</a>
Sydni Credle	NETL	<a href="mailto:sydni.credle@netl.doe.gov">sydni.credle@netl.doe.gov</a>
Antonio Trujillo	Eaton Corporation	<a href="mailto:antonio.trujillo@eaton.com">antonio.trujillo@eaton.com</a>
James Stoupis	ABB	<a href="mailto:James.stoupis@us.abb.com">James.stoupis@us.abb.com</a>
Mirrasoul Mousavi	ABB	<a href="mailto:Mirrasoul.j.mousavi@us.abb.com">Mirrasoul.j.mousavi@us.abb.com</a>

Initially, the working group was asked to review and comment on the relevant section of the Technology Review and Assessment Document to become familiar with the current state of the art used in developing the initially proposed research thrusts within the Asset Health Monitoring area. The team was then asked to critically review and comment on the initially proposed set of research thrusts developed by the DOE laboratory team and to provide insights into potential gaps that exist in terms of sensor device technology within this area.

Based on team member input, a decision was made to refocus potential research thrusts around specific parameters (e.g., temperature, dissolved gases in insulation oils, vibrations) to be measured rather than application domains (e.g., large power transformer monitoring, conventional generator monitoring, substation monitoring). The full list of the modified set of potential research thrusts considered appears in Section D.3.3. The team then developed a set of quantitative metrics around the selected parameters including (1) technical performance, (2) spatial characteristics, and (3) total cost of installation, among others. Based upon the developed metrics, a survey of existing commercial sensors was performed to seek what commercially available options could be identified, including the request of full quotations from

vendors to gain access to estimated costs. These commercial sensors are not referenced explicitly in this document because of sensitivities associated with proprietary information, but the information gathered provided a basis for the key findings outlined, including the gap analysis summary table presented in Section D.3.4.

### D.3.3 Key Findings and Recommendations

The team identified many key findings during the working group process, which lead to the subsequent proposed research thrusts. A summary of the most significant identified gaps, the proposed approaches to address the gaps, and their linkages to the proposed research thrusts appear in the summary table in Section D.3.4. Key findings include these:

1. There are many existing, commercial technologies for electrical grid asset health monitoring, but their deployment is limited by the total cost of installation to assets for which the return on investment is clear and obvious to the owner of the asset. ***Federal research efforts on asset monitoring of electrical grid assets should specifically target (1) dramatic reductions in cost for comparable performance to existing commercial technologies and (2) extremely low-cost sensing approaches that can enable access to parameters of interest with adequate but reduced overall performance levels.***
2. Generation assets, such as fossil- and nuclear-based plants, impose extreme constraints on asset health monitoring sensing technologies due to operational temperatures, pressures, erosive/corrosive conditions, and the potential for radiation exposure. In contrast to electrical grid assets, only a very limited number of commercial sensors exist that can satisfy these application requirements, yet their increased requirement for flexible operation increases the need for real-time asset health monitoring. ***Federal research efforts on asset health monitoring of conventional generation assets should specifically target high-temperature and harsh environmental performance operational conditions with cost as a secondary consideration.***
3. Temperature is a key parameter in the early identification of faults and failures in assets across the modern power system. ***Federal research efforts should target novel temperature sensing approaches for internal asset monitoring through emerging technologies with unique characteristics, such as compatibility with deployment internal to both electrical grid and generation assets.***
4. Electrical parameter measurements can provide the most rapid signatures of low-probability, high-consequence events, such as manmade or natural events, to enable mitigation action that can prevent large-scale failures and minimize impacts. ***Federal research efforts should target rapid, high-bandwidth and low-latency electrical parameter measurements.***
5. A unique value proposition exists for asset health monitoring sensors that (1) are capable of monitoring multiple parameters of interest simultaneously (e.g., temperature, pressure, and gas phase chemistry), (2) are compatible with internal electrical and generation asset deployment, and (3) enable spatially distributed measurements. ***Federal research efforts should target sensor technology platforms with these unique characteristics, such as optical and passive wireless sensor device technologies as well as areal imaging-based techniques.***
6. Indirect measurements of proxy parameters that are relatively easy and inexpensive to take are often sufficient. Such instruments can take measurements external to an asset and provide insights about asset health and faults/failures. ***Federal research efforts should encourage development of ultra-low-cost proxy-based sensing platforms.***

7. For well-established sensing technologies such as dynamic line rating systems, standards for data management, data transfer, and communication can be a major barrier for widespread implementation of new sensing and measurement technologies beyond the substation. Regulations that encourage adoption of new, large capital grid assets may also inadvertently discourage the implementation and adoption of sensing technologies that can be used to extract additional value from existing assets. ***Federal regulations and standards should be critically reviewed to consider their potential impact on new sensing and measurement technology deployment, including both intentional and inadvertent impacts***

### D.3.4 Gap Analysis Summary

Gaps identified by working group	Relevant research thrust or thrusts	Approach to address gap	Key metrics to be addressed
Grid asset monitoring technologies exist, but deployment is limited by cost	All	Develop multi-tiered metrics to balance performance/cost tradeoffs Dramatically reduce cost for existing performance and enable new lower-cost sensors with reduced performance	Performance and cost
Dissolved gas analysis (DGA) plays a key role in asset health monitoring of transformers but is cost prohibitive	Research thrust 1: Real-time DGA sensors	Develop DGA technologies of varying performance for specific application ranges but with dramatically reduced costs	Performance and cost
Nontraditional proxies can be deployed for early detection of fault conditions	Research thrust 6: Vibration event detection Research thrust 7: Acoustic event detection	Develop low-cost proxies that can be ubiquitously applied to grid assets	Efficacy as a proxy, cost
Local monitoring of utility pole and line orientation can enable prevention of failures and more rapid recovery and restoration times	Research thrust 10: Pole tilt and line sag monitoring	Develop low-cost tilt sensors for poles and lines that can be ubiquitously applied to grid assets	Performance and cost.
Non-localized signatures of failures or faults are difficult to detect with individual sensors	Research thrust 8: Areal temperature monitoring through imaging Research thrust 9: Areal gas insulation leak monitoring through imaging Research thrust 11: Line temperature profile Research thrust 12: Line acoustic monitoring	Develop techniques that enable areal imaging or linear mapping of parameters of interest with optimal trade-offs in spatial resolution, cost, and performance	Areal or linear spatial resolution, performance, and cost
Thermal signatures are a primary indicator of grid asset health faults/failures, but internal temperatures exhibit characteristic hot spots that can be difficult to detect	Research thrust 2: Grid asset internal temperature	Develop multipoint temperature sensor technologies and extremely low-cost single-point sensor technologies for improved monitoring	Number of sensor nodes and cost

Gaps identified by working group	Relevant research thrust or thrusts	Approach to address gap	Key metrics to be addressed
Energy storage will play an increasingly key role in grid resiliency and stability moving forward	Research thrust 13: Internal chemistry (energy storage) Research thrust 14: State of charge (energy storage)	Develop new sensor technologies capable of real-time monitoring of energy storage performance/ degradation	Performance, cost, and compatibility with internal energy storage deployment
Existing generation plant monitoring will be increasingly important in the future because of needs for more flexible operation	Research thrust 2: Grid asset internal temperature Research thrust 3: Grid asset internal strain Research thrust 7: Acoustic event detection Research thrust 15: Boiler water chemistry monitoring	Several specific metrics were developed around the needs of internal monitoring of centralized generators. A specific research thrust was also developed for boiler water chemistry monitoring	High-temperature compatibility, performance
Electrical parameters can provide the most rapid signatures of low-probability, high-consequence events, such as human or natural threats (e.g., geomagnetic disturbance, electromagnetic pulse)	Research thrust 4: Fault-current detection Research thrust 5: Under/overvoltage transient monitoring	Development of rapid, high-bandwidth, and low-latency electrical parameter measurements with sufficiently low cost for ubiquitous deployment	Performance, latency, bandwidth, and cost
Regulations that promote deployment of new sensing technologies rather than replacement of large existing capital assets	Recommendation made to the crosscutting working group	Provide a forum for discussing business model challenges for new sensor deployment by industry	Regulation efficacy and awareness by regulation bodies
Standardized data and communication protocols for new sensors not integrated within components or substations	Recommendation made to the crosscutting, data management, and data analytics working groups	More clearly communicate the challenges associated with using new sensor data as a barrier to deployment and implementation	Standard efficacy and awareness by standards organizations

### D.3.5 Proposed Research Thrusts and Prioritization

Based upon the results of the working group efforts and the associated gap analysis, a total of 15 different research thrusts were initially developed for consideration and discussion, as listed below. To minimize overlap with other focus areas, this number was condensed and reduced to ten different research thrusts. Of these research thrusts, seven are being recommended for prioritization, as indicated below.

Research thrusts developed (initial):

1. Real-time dissolved gas analysis (DGA) sensors
2. Grid asset internal temperature
3. Grid asset internal strain
4. Fault-current detection
5. Under/overvoltage transient monitoring
6. Vibration event detection
7. Acoustic event detection
8. Areal temperature monitoring through imaging

9. Areal gas insulation leak monitoring through imaging
10. Pole tilt and line sag monitoring
11. Line temperature profile
12. Line acoustic monitoring
13. Internal chemistry (energy storage)
14. State of charge (energy storage)
15. Boiler water chemistry monitoring

Research thrusts developed (after combining with other working groups):

1. Real-time dissolved gas analysis sensors (recommended)
2. Grid asset internal temperature (recommended)
3. Grid asset internal strain
4. Acoustic and ultrasonic vibration event detection (recommended)
5. Areal temperature and gas insulation leak monitoring through imaging
6. Pole tilt and line sag monitoring (recommended)
7. Line temperature profile (recommended)
8. Line acoustic monitoring
9. Internal chemistry (energy storage) (recommended)
10. Boiler water chemistry monitoring (recommended)

#### **D.3.6 Relation with Existing GMLC/GMI Efforts**

The proposed research thrusts for prioritization are being addressed to some extent through existing efforts supported under the GMLC and the GMI more broadly. Research focused on real-time DGA sensors (research thrust 1), as well as the grid asset internal temperature (research thrust 2) sensors is being pursued under the GMLC Advanced Sensor Development Project by leveraging the microwave surface acoustic wave sensor-based platforms (ORNL) and the optical fiber-based platforms (NETL). An existing effort under the GMLC Advanced Sensor Development project also targets passive microwave sensor technology, referred to as “MagSense,” for ubiquitous grid asset fault current monitoring. An existing program is also being carried out under a recent solicitation by DOE’s Office of Electricity: it targets advanced distribution sensors, on the topic of optical fiber-based sensors, in a program being led by PARC in collaboration with General Electric. Despite the ongoing efforts in this area within the GMLC and GMI, clear opportunity exists to expand upon the area of asset health monitoring to address the targeted research thrusts recommended by the working group.

### **D.4 PHASOR MEASUREMENT UNITS FOR GRID STATE AND POWER FLOW (LABORATORY LEAD: YAROM POLSKY, ORNL)**

#### **D.4.1 Scope of Working Group**

Phasor measurement units (PMUs) are a critical enabling technology for providing system visibility and control capability. They have become more widely used to measure and time-stamp basic electrical parameters in modern systems since 2009. But significant improvements in both performance and cost are still required to achieve grid modernization goals related to situational awareness and dynamic, real-time control. Historical use of PMUs has primarily focused on post-mortem diagnosis of grid events. The cost-reduction and performance improvement goals described in the subtopics of this focus area are intended to catalyze wider and more rapid adoption of PMUs across the grid and to enable novel dynamic control implementations that significantly enhance observability, control, and reliability. This working group reviewed the current proposed PMU research thrusts areas with respect to the current industrial state of the art and quantitative metrics for new PMU technology development.

## D.4.2 Working Group Process

The PMU working group established a core group of stakeholders spanning the DOE national laboratory system, academia, utilities, and vendors. The following is a full list of participants.

Name	Organization	Contact information
Alireza Shahsavari	University of California–Riverside	<a href="mailto:ashah023@ucr.edu">ashah023@ucr.edu</a>
David Schoenwald	SNL	<a href="mailto:daschoe@sandia.gov">daschoe@sandia.gov</a>
Emma Stewart	LLNL	<a href="mailto:stewart78@llnl.gov">stewart78@llnl.gov</a>
Eugene Song	NIST	<a href="mailto:eugene.song@nist.gov">eugene.song@nist.gov</a>
Evangelos Farantatos	Electrical Power Research Institute	<a href="mailto:efarantatos@epri.com">efarantatos@epri.com</a>
Felipe Wilches-Bernal	SNL	<a href="mailto:fwilche@sandia.gov">fwilche@sandia.gov</a>
Gordon Mathews	Bonneville Power Administration.	<a href="mailto:ghmatthews@bpa.gov">ghmatthews@bpa.gov</a>
Jaya Yellajosula	Michigan Tech	<a href="mailto:jvellajo@mtu.edu">jvellajo@mtu.edu</a>
Jerry Fitzpatrick	NIST	<a href="mailto:gerald.fitzpatrick@nist.gov">gerald.fitzpatrick@nist.gov</a>
Junbo Zhao	NASPI Distribution Task Team/PNNL	<a href="mailto:junbobzhao@gmail.com">junbobzhao@gmail.com</a>
Linwei Zhan	ORNL	<a href="mailto:zhanl@ornl.gov">zhanl@ornl.gov</a>
Reza Arghandeh	Florida State University	<a href="mailto:reza@caps.fsu.edu">reza@caps.fsu.edu</a>
Sarma Nuthalapati	Peak	<a href="mailto:snuthalapati@peakrc.com">snuthalapati@peakrc.com</a>
Sascha von Meier	University of California–Berkeley	<a href="mailto:vonmeier@berkeley.edu">vonmeier@berkeley.edu</a>
Shaun Murphy	PJM	<a href="mailto:Shaun.Murphy@pjm.com">Shaun.Murphy@pjm.com</a>
Sumit Paduyal	Michigan Tech	<a href="mailto:sumitp@mtu.edu">sumitp@mtu.edu</a>
Tom Rizy	ORNL	<a href="mailto:dtom@ornl.gov">dtom@ornl.gov</a>
Venkat Krishnan	NREL	<a href="mailto:Venkat.Krishnan@nrel.gov">Venkat.Krishnan@nrel.gov</a>
Yarom Polsky	ORNL	<a href="mailto:yp4@ornl.gov">yp4@ornl.gov</a>
Yilu Liu	University of Tennessee	<a href="mailto:liu@utk.edu">liu@utk.edu</a>

Initially, the working group was asked to review and comment on the relevant section of the Technology Review and Assessment Document to familiarize members with the current state of the art used in developing the initially proposed research thrusts within the PMU area. The team was then asked to critically review and comment on the initially proposed set of research thrusts developed by the DOE national laboratory team and to provide insights into potential gaps that exist in terms of sensor device technology within this area.

Based on team member input, a decision was made to consolidate the initial five thrust areas into three based on primary PMU characteristics of interest: performance, cost, and reliability. In some respects, the PMU topic is relatively narrow and the technology is relatively mature. On the other hand, the information provided by PMUs is critical to grid monitoring and control, and the technology requires significant improvements to increase both its market penetration and performance that enables improved situational awareness and power flow control of the grid. For example, while PMU coverage of the transmission system is reasonably complete, coverage in the distribution system is sparse to nonexistent. Realizing this more granular observability of grid power state is primarily hampered by challenges associated with PMU costs, including installation and operation and maintenance (O&M). Additionally, high-speed, real-time control applications necessitate an estimated 1 to 2 order of magnitude improvement in PMU dynamic performance and reliability. The proposed improvements should be evaluated both

individually and collectively since, in some instances, they may be at odds with each other (e.g., performance vs. cost). The interrelationships between thrusts and gaps should similarly be considered in the following gap analysis and recommendations.

### D.4.3 Key Findings and Recommendations

The team identified a number of key findings during the working group process, which led to the proposed research thrusts. A summary of the most significant identified gaps, the proposed approaches to address the gaps, and their linkages to proposed research thrusts can be found in the summary table in Section D.4.4. Key findings include these:

1. The proposed dynamic performance requirements for PMUs are currently based on academic studies, since actual controls demonstrations using PMU data are limited. Future dynamic and distributed controls demonstrations will permit refinement of PMU performance parameters against real-world data sets. ***Federal research efforts should periodically reevaluate the dynamic performance requirements of PMUs based on advanced controls implementations and demonstrations.***
2. While the unit cost ranges of PMUs are known and easily updated, life cycle costs of PMUs—including installation, operation, and maintenance—are less certain. ***Federal research efforts focused on lowering the costs of PMUs should develop more comprehensive, data-based life cycle cost models of PMUs to formulate more accurate and relevant cost targets.***
3. There are a significant number of PMUs that have already been installed and are in commercial use. Most of these systems do not meet the target performance and reliability metrics proposed in the research thrust areas. ***Federal research efforts focused on lowering the costs of PMUs should also consider both the costs and benefits associated with retrofitting existing PMU installations.***
4. The proposed reliability metrics should be more formally evaluated and refined. In particular, the proposed reliability metrics should be considered in the context of both existing IEEE timing standards and future control and situational awareness goals. ***Federal research efforts should develop a justification for proposed reliability metrics.***

### D.4.4 Gap Analysis Summary

Gaps identified by working group	Relevant research thrust or thrusts	Approach to address gap	Key metrics to be addressed
Performance metrics are aspirational and need to be updated as controls applications evolve	Improve the dynamic response and accuracy of PMUs	Reevaluate metrics against findings of pilot controls projects	All
Cost data are incomplete or need to be updated—particularly O&M costs	Lower the cost of PMUs	Industry survey	Cost
There may be a need to differentiate and consider cost metrics with regard to both new PMU installations and retrofits	Lower the cost of PMUs	Market evaluation and preliminary scoping study	Retrofit cost vs. new system cost
Reliability metrics need to be	Improve PMU timing	Need to develop case and	Timing service reliability

Gaps identified by working group	Relevant research thrust or thrusts	Approach to address gap	Key metrics to be addressed
justified	reliability	justification for specified metrics. These must be considered with respect to current IEEE timing standard	

#### D.4.5 Proposed Research Thrusts and Prioritization

Based upon the results of the working group efforts and the associated gap analysis, a total of three different research thrusts were developed for consideration and discussion, as follows.

Research thrusts developed:

1. Improve the dynamic response and accuracy of PMUs (recommended)
2. Lower the cost of PMUs (recommended)
3. Improve PMU timing reliability (recommended)

#### D.4.6 Relation with Existing GMLC/GMI Efforts

One currently funded project, Advanced Sensor Development, in the Sensing and Measurement GMLC technical area, has a subset of tasks related to PMU algorithm development. Specifically, it aims to “develop advanced PMU algorithms for ultra-fast transient measurements during disturbances and to integrate PMU algorithms into optical transducers for high-accuracy steady state monitoring.” This project does not directly address the goals of the proposed thrust areas but is considered to be complementary with respect to its performance goals. There are also three synchrophasor data end-use projects currently funded through GMLC. One is focused on developing tools for more efficiently using synchrophasor data and the other two projects are focused on applications of synchrophasor data. One investigates high-voltage direct current load modulation using synchrophasor data, and the other seeks to improve situational awareness of grid state by applying machine learning to synchrophasor data sets. There are no active projects focused specifically on PMU improvement or cost reduction, to the knowledge of the working group.

### D.5 NOVEL TRANSDUCERS—ENCOMPASSES SENSORS FOR DYNAMIC SYSTEM PROTECTION, GRID ASSET FUNCTIONAL PERFORMANCE MONITORING, SENSORS TO ENABLE ADVANCED GENERATION CONTROLS, NOVEL VOLTAGE AND CURRENT TRANSDUCERS (LABORATORY LEAD: OLGA LAVROVA, SNL)

#### D.5.1 Scope of Working Group

Novel electrical transducers can have an impact across a broad range of applications and use cases in the transmission and distribution system. To explore synergies and crosscutting opportunities, this working group focused on the development and application of novel voltage and current transducers across proposed focus areas, including (1) dynamic system protection, (2) grid asset functional performance monitoring, and (3) enabling of advanced controls and functionality multiple assets and coordination between them. This working group reviewed the current proposed research thrusts within these focus areas of the Roadmap and developed a clear understanding of the current industrial state of the art and quantitative metrics for new sensing and measurement technology development. The group made

recommendations regarding opportunities for leveraging synergies across the originally identified focus areas encompassed by this broader topical area.

### D.5.2 Working Group Process

The Novel Transducers working group established a core group of stakeholders spanning the DOE national laboratory system, academia, utilities, and vendors. The following is a full list of participants.

Name	Organization	Email
Olga Lavrova	SNL	<a href="mailto:olavrov@sandia.gov">olavrov@sandia.gov</a>
Farnoosh Rahmatian	NuGridPower/NASPI PRSVTT	<a href="mailto:frahmatian@nugridpower.com">frahmatian@nugridpower.com</a>
Eugene Song	NIST	<a href="mailto:eugene.song@nist.gov">eugene.song@nist.gov</a>
Alireza Shahsavari	NASPI Distribution Task Team/ University of CA–Riverside	<a href="mailto:ashah023@ucr.edu">ashah023@ucr.edu</a>
Tim McIntyre	ORNL	<a href="mailto:mcintyretj@ornl.gov">mcintyretj@ornl.gov</a>
Peter Fuhr	ORNL	<a href="mailto:fuhrpl@ornl.gov">fuhrpl@ornl.gov</a>
Marissa Morales-Rodriguez	ORNL	<a href="mailto:moralesme@ornl.gov">moralesme@ornl.gov</a>
Venkat Shastri	NASPI Distribution Task Team/ University of San Diego	<a href="mailto:venkat@sandiego.edu">venkat@sandiego.edu</a>
Jack Flicker	SNL	<a href="mailto:jdflick@sandia.gov">jdflick@sandia.gov</a>
Eugene Song	NIST	<a href="mailto:eugene.song@nist.gov">eugene.song@nist.gov</a>
Junbo Zhao	NASPI Distribution Task Team/PNNL	<a href="mailto:junbobzhao@gmail.com">junbobzhao@gmail.com</a>
Kang Lee	NIST	<a href="mailto:kang.lee@nist.gov">kang.lee@nist.gov</a>
Lilian Bruce	Electric Power Board of Chattanooga	<a href="mailto:brucelb@epb.net">brucelb@epb.net</a>
Harold Kirkham	PNNL	<a href="mailto:Harold.Kirkham@pnnl.gov">Harold.Kirkham@pnnl.gov</a>
Reza Arghandeh	Florida State University	<a href="mailto:r.arghandeh@fsu.edu">r.arghandeh@fsu.edu</a>
Scott Averitt	Bosch	<a href="mailto:Scott.Averitt@us.bosch.com">Scott.Averitt@us.bosch.com</a>

Initially, the working group was asked to compile a comprehensive list of distribution grid sensors that are currently commercially available, both commercial-off-the-shelf and state-of-the-art. The team was then asked to critically review and comment on functional gaps present in the list and then provide insights into potential gaps that exist in terms of sensor device technology within this area.

### D.5.3 Key Findings and Recommendations

During the working group process, the team identified key finding , which led to proposed research thrusts. The summary table in Section D.5.4 summarizes the most significant identified gaps, proposed approaches to address the gaps, and their linkages to proposed research thrusts. Key findings are these:

1. At the core of smart power distribution systems are smart devices that enable facility managers to take preventive measures to mitigate potential risks. These devices have become more than just responsible for controlling a single mechanism. They now measure and collect data and provide control functions. Furthermore, they enable facility and maintenance personnel to access the power distribution network.
2. Many existing commercial technologies (transducers and sensors) exist for electrical grid monitoring, including monitoring at the grid-edge. However, the usability of information produced and reported

by these transducers and sensors is limited because of the lack of a framework for information reporting. Translating information into actionable information also is constrained by the lack of a framework. ***Federal research efforts on novel transducers and electrical parameter sensors for electrical grid assets should specifically target (1) transducers and sensors providing actionable information and 2b) a unified framework of parameter reporting and information processing.***

3. Electrical parameter measurements can provide the most rapid signatures of low-probability, high-consequence events, man-made or natural. These measurements can enable preventative action to prevent large-scale failures and minimize impacts, resulting in increasing grid resiliency. ***Federal research efforts should target rapid, high-bandwidth and low-latency electrical parameter measurements.***
4. In most cases, abnormal behavior (e.g., failures, faults, or severe degradation of performance of an asset) manifests itself in a deviation from nominal operating frequency or the presence of abnormal frequencies (such as new harmonics or completely new frequency characteristics). Detecting such a frequency is a key parameter in the early identification of faults and failures in assets across the modern power system. ***Federal research efforts should target novel frequency-selective sensors that can provide fundamentally new information (relative to sensing at 60 Hz).***
5. On the opposite side of the spectrum, extremely low-cost but ubiquitous transducers could provide single-parameter reporting at a significantly low cost. Big data processing methods can be extremely useful for processing substantial amounts of single-parameter data over large geographical scales and translating these data into actionable information across balancing authority or regional control area scales. ***Federal research efforts should specifically target extremely low-cost sensing approaches that can enable access to parameters of interest with adequate but reduced overall performance levels.***
6. A unique value proposition exists for sensors that (1) are capable of monitoring multiple parameters of interest simultaneously, (2) are compatible with internal electrical and generation asset deployment, and (3) enable spatially distributed measurements. ***Federal research efforts should target sensor technology platforms with these unique characteristics, such as optical and passive wireless sensor device technologies and areal imaging based techniques.***

#### D.5.4 Gap Analysis Summary

Gaps identified by working group	Relevant research thrust or thrusts	Approach to address gap	Key metrics to be addressed
Grid asset monitoring technologies exist, but deployment is limited by cost	All	Develop multi-tiered metrics to balance performance/cost trade-offs Dramatically reduce cost for existing performance and enable new lower-cost sensors with reduced performance	Performance and cost
Fast-acting broadband sensors for dynamic system protection These sensors must quickly sense and transmit their data, so that relays and switches can be	Research thrust 1: Frequency-selective current sensing Research thrust 2: Fault-current detection Research thrust 3: Location of the fault detection Research thrust 4:	Development of frequency-selective high-bandwidth, and low latency electrical current measurements with sufficiently low cost for ubiquitous deployment	Frequency range, dynamic range for voltage and current, latency, cost

Gaps identified by working group	Relevant research thrust or thrusts	Approach to address gap	Key metrics to be addressed
<p>activated to protect grid equipment from damage. Sensors must be capable of detection with performance (e.g., response time, accuracy, precision) to meet the requirements of adaptive protection schemes</p>	<p>Optical CT/PTs</p>		
<p>Performance sensors for next-generation (solid-state) transformers</p>	<p>Research thrust 5: Accurate harmonics and total harmonic distortion (THD) measurement            Research thrust 6: Accurate pulse width modulation (PWM) diagnostics</p>	<p>Development of a new set of transducers capable of providing accurate information about frequency content and THD</p>	<p>Frequency range, dynamic range, latency, cost</p>
<p>Derivative sensors Like ROCOF (rate of change of frequency), derivative sensors for voltage and current may be very useful for utilities for monitoring of dynamic operating states</p>	<p>Research thrust 7: Voltage derivative sensors            Research thrust 8: Current derivative sensors            Research thrust 9: Frequency derivative sensors (ROCOF)</p>	<p>Develop a new set of transducers capable of providing information about rates of changes (dynamic) of voltage, current, and frequency.</p>	<p>Frequency range, dynamic range, latency, cost</p>
<p>Electrical parameter measurements for energy storage            Energy storage will play an increasingly key role in grid resiliency and stability moving forward</p>	<p>Research thrust 10: State of charge/discharge (energy storage)            Research thrust 11: Rate of charge/discharge (energy storage)            Research thrust 12: Depth of discharge (energy storage)            Research thrust 13: Cumulative (lifetime) number of charge/discharge cycles (energy storage)            Research thrust 14: Cumulative (lifetime)</p>	<p>Develop new sensor technologies capable of real-time monitoring of energy storage performance/ degradation</p>	<p>Performance, cost, compatibility with internal energy storage deployment</p>

Gaps identified by working group	Relevant research thrust or thrusts	Approach to address gap	Key metrics to be addressed
	kWh (energy storage)		
Behind-the-meter (customer) sensing. Transducers creating actionable information from all the new smart devices, which may be installed behind the meter (customer) location	Research thrust 15: Novel behind-the-meter transducers	Solutions that monitor performance of several devices and broadcast this information to the utility. A possible smart outlet, which can collect power and power quality information, is another example. A complete solution would be a smart meter, which provides not only revenue information but also power and power quality information for all devices at the customer's interconnection location	System integration of the sensors and cost
Standardized data and communication protocols for novel transducers not integrated within components or substations	Recommendation made to the crosscutting, data management, and data analytics working groups	More clearly communicate the challenges associated with using new transducer data as barriers to deployment and implementation	Standard efficacy, awareness by standards organizations, "death by big data"

### D.5.5 Proposed Research Thrusts and Prioritization

Based upon the results of the working group efforts and the associated gap analysis, a total of 15 different research thrusts (listed below) were developed for consideration and discussion. Based on further discussions within this workgroup and in discussion with other workgroups, ten of the initially proposed workgroups (listed below) were merged, renamed, and recommended to proceed.

Research thrusts developed initially:

1. Frequency-selective current sensing
2. Fault-current detection
3. Location of the fault detection
4. Optical current transformers/potential transformers
5. Accurate harmonics and THD measurement
6. Accurate PWM diagnostics
7. Voltage derivative sensors
8. Current derivative sensors
9. Frequency derivative sensors (ROCOF)
10. States of charge/discharge (energy storage)
11. Rate of charge/discharge (energy storage)
12. Depth of discharge (energy storage)
13. Cumulative (lifetime) number of cycles (energy storage)
14. Cumulative (lifetime) kWh (energy storage)
15. Novel behind-the meter transducers

Research thrusts developed after consolidation, all of which are recommended to proceed:

1. Fast-acting current sensors for fault detection and dynamic system protection
2. Fast-acting voltage sensors for fault detection and dynamic system protection
3. Grid asset health and performance monitoring (traditional transformers)
4. Performance sensors for next-generation (solid state) transformers
5. Electrical parameter measurements for energy storage
6. Fast-acting sensors (other than voltage and current) for dynamic system protection
7. Derivative sensors
8. Broadband frequency-selective current sensor
9. Behind-the-meter (customer) sensing
10. Maturation of all-optical transducer technologies

#### **D.5.6 Relation with Existing GMLC/GMI Efforts**

The proposed research thrusts for prioritization are being addressed to some extent through existing efforts supported under the GMLC and, more broadly, the GMI. In particular, an existing effort under the GMLC Advanced Sensor Development project also targets passive microwave sensor technology, or MagSense, for ubiquitous grid asset fault current monitoring (research thrust 6).

Despite the ongoing efforts in this area within the GMLC and GMI, a clear opportunity exists to expand upon the area of development of novel transducers that can sense and communicate new actionable information, which will lead to more informed and robust electric grid and asset controls.

### **D.6 WEATHER MONITORING AND FORECASTING (LABORATORY LEAD: VENKAT KRISHNAN, NREL)**

#### **D.6.1 Scope of Working Group**

Increasing penetrations of weather-dependent renewable energy sources are making weather sensors even more important for monitoring and predicting generation. Installed capacities of solar photovoltaic (PV), concentrating solar power (CSP), and wind energy have grown significantly in recent years, to the point that they have a significant impact on generation profiles. Grid integration of these renewable energy systems benefits from the operational awareness provided by real-time sensing of both wind and solar resources and energy production, as well as forecasting from weather prediction over time scales from 0–5 minutes to 24–48 hours ahead. Additionally, weather forecasts provide valuable information for forecasting electricity consumption. This working group will review the current proposed research thrusts within this focus area of the Sensing and Measurement Technology Roadmap and develop a clear understanding of the current industrial state of the art and quantitative metrics for new sensing and measurement technology development.

#### **D.6.2 Working Group Process**

The Weather Monitoring and Forecasting working group established a core group of stakeholders spanning the DOE national laboratory system, academia, industry, and sensing instrumentation vendors. The following is a full list of participants.

<b>Person</b>	<b>Organization</b>	<b>Expertise</b>
Manajit Sengupta	NREL	Sensors for wind and solar forecasting
Dan Riley and Matt Lave	SNL	PV sensing and measurements
Tim McIntyre	ORNL	Sensors for harsh environments
Venkat Krishnan	NREL	Venkat.Krishnan@nrel.gov

Person	Organization	Expertise
Jan Kleissl	University of CA–San Diego (UCSD)	Weather station network at the UCSD campus
Steve Miller	Colorado State University	Satellite remote sensing of solar radiation
Qilong Min	University at Albany–Sunny	Weather sensing and NY mesonets for resilience
Melinda Marquis	National Oceanic and Atmospheric Administration	Weather forecasts for wind and solar power applications, at Earth System Research Laboratory
Sue Haupt	National Center for Atmospheric Research	Wind and solar forecasting from Weather Research and Forecasting model
Aidan Tuohy	EPRI	Forecast integration into independent system operator and utility operations
Gail Vaucher	Army Research Laboratory	Sensors in harsh environments
Justin Robinson	GroundWork Renewables	Meeting during NREL’s annual Pyrheliometer Comparisons event: Expertise in solar monitoring, measurement, instrumentation, data logging and data processing–utility-scale PV
Erik Naranen	ISO-CAL North America (lab quality manager)	
Tom Kirk	Eppley Lab, President	
Wim Zaaiman	Joint Research Centre, Italy	
Victor Cassella	Kipp & Zonen USA Inc.	
Chris Kern	Irradiance	
Josh Peterson	University of Oregon	
Aron Habte, Mike Dooraghi, Mark Kutchenreiter	NREL	

The working lead had several meetings with each of the experts, either in person or electronically, to review the roadmap content and research thrusts and solicit input on the following questions:

- Are there any important measurement parameters and sensing technologies that have been left out of the technology review document and the roadmap document, specifically related to harsh environments such as mountains, arctic conditions, and offshore wind systems?
- Are the research thrusts identified the most important ones? If yes, why? If not, why? What other research thrusts can be included?
- Are the quantitative metrics identified in the research thrusts valid and viable to achieve?
- Can you point to some past and current studies/literature related to weather monitoring and forecasting that could be used to update the technology review document?

Each of these conversations, including direct edits to the review document provided by some of the experts, laid the foundation to revise the technology review document, perform gap analysis between current state of the art and future needs, develop high-priority research thrusts in this focus area, and update the roadmap document.

### D.6.3 Key Findings and Recommendations

Based on team member input, the major comments or recommendations included the following three research thrusts:

1. **Optimal allocation of sensors considering cost and reliability:** It is vital to consider the vast amount of existing weather-monitoring sensor and measurement infrastructure and find ways to harness it for various grid modeling and operational purposes, before we seek to deploy newer weather-monitoring infrastructures.
2. **Developing reliable sensors for harsh environments:** Highly reliable weather-monitoring instrumentation already exists. In considering the cost and reliability of a weather sensing device, it will be important to look at the entire system (including communication and data processing) rather than just particular devices. The reliability of such sensor systems, especially in remote harsh environments, depends largely on resources being allocated, such as maintenance budget, personnel, robust communication channels, error detection in data assimilation process, and quality checks. The reliability needs and associated maintenance budgets may be dictated by the end-use applications.
3. **Distributed smart sensors (with onboard analytics):** While this concept may seem interesting, given that many sensing technologies with onboard analytics already in use, the use case and benefits are hard to see. There should be a thrust to understand the requirements of weather sensors in terms of reliability, accuracy, communication latency, local vs. central data analytics ability, and so on, for various grid applications.

Specific suggestions were made to include research thrusts for advancing variable renewable forecasts, and uncertainty quantification and grid-edge resource observability. Additionally, concerns were raised regarding integrating the available weather monitoring data into grid operation and decision-making platforms in the form of advanced forecasts and visualizations for situational awareness and grid resilience. Specifically, suggestions were provided to better represent the integration of severe weather event data such as floods, lightning, fire, and storms. Such integration will serve as a driver for further innovations in the weather-monitoring and forecasting area by pushing the boundary on current sensing system performances.

The table in Section D.6.4 presents detailed descriptions of the gap analysis.

#### D.6.4 Gap Analysis Summary

Gaps identified by working group	Relevant research thrust or thrusts	Approach to address gap	Key metrics to be addressed
<p>Many weather-monitoring and measurement resources exist in the nation, but awareness and collaboration are needed to use them for various grid modernization applications</p> <p>Technologies for scalable deployment and grid-edge observability need to be researched</p>	<p>Research thrust 1: Harnessing existing weather monitoring resources</p>	<p>Harness existing weather monitoring resources (e.g., satellite data, mesonets, weather stations) by creation of a consortium made up of key personnel responsible for data generation, communication, assimilation and end use</p> <p>Research low-cost technology options and scalable deployment</p> <p>Research innovative technology integration and portable high-quality calibration techniques for various applications</p> <p>Facilitate public and private data partnership</p>	<p>Data availability at various spatial and temporal resolutions</p> <p>Cost of data acquisition</p>

Gaps identified by working group	Relevant research thrust or thrusts	Approach to address gap	Key metrics to be addressed
		Comprehensively document disparate data resources by key measurement parameters	
Standardization of weather monitoring and forecasting data needs attention, because this enables efficiency and innovation. Standardization must be extended from meteorological to forecast data reporting	Research thrust 2: Framework for disparate data processing and standardization for utility integration	<p>Work with utilities and independent system operators (ISOs) to understand format variations and rationales</p> <p>Develop a framework for distributed data assimilation of weather data, quality assurance, data analytics for applications, and derived data reporting format standardization</p>	<p>Cost of data storage and maintenance</p> <p>Data curating rates (processing and quality assurance)</p>
Better integration of weather-monitoring data is needed for various grid modernization applications at both transmission and distribution systems	All research thrusts 1–5	<p>Understand the weather monitoring resources</p> <p>Develop a framework to ingest a wide variety of data</p> <p>Improve forecast models and visualizations and integrate them into various ISO and utility operations and planning applications</p>	<p>Forecast accuracy</p> <p>Cost of data acquisition</p> <p>Data availability</p> <p>Power system operational economics and reliability</p>
Innovative forecasting models that not only forecast the mean power but also its ramps and associated uncertainties are needed, along with their integration into grid decision support processes	Research thrust 3: Advanced forecasting models and their integration	<p>Develop advanced forecasting models for probabilistic forecasts of load, variable renewables and net-load power and ramps</p> <p>Use big data analytics in conjunction with numerical weather prediction for developing probabilistic forecast models</p> <p>Work with industry to evaluate the value proposition and recommend best practices of forecast integration</p> <p>Validate satellite data-based on-ground mounted sensors and improve the spatial and temporal resolutions of forecasting models</p>	<p>Forecast accuracy</p> <p>Uncertainty quantification of mean power and ramp forecasts</p> <p>Lean reserve procurements for grid operation</p> <p>Observability of grid topology and states for various utility applications</p> <p>Improved system reliability</p>
A decision support tool is needed to enable situational awareness and timely decision making by system operators to ensure reliability	Research thrust 4: Real-time visualization and situational awareness  (Overlaps with research thrust 3: Advanced	Work with ISO and utility to develop visualization software that can integrate live forecast feeds into energy management system and distribution	<p>Short-term forecast accuracy</p> <p>Rate of forecast updates</p>

Gaps identified by working group	Relevant research thrust or thrusts	Approach to address gap	Key metrics to be addressed
now and in the future, enabling transactive markets at the customer level	forecasting models and their integration, and with thrust 5: Establishing requirements and optimizing weather sensing infrastructure for different smart grid applications)	management system platforms Evaluate value proposition and recommend best practices for operational decision making with visualization tools Train operators Develop onboard data analytics for sensing systems, for faster communication and local decision making	Accuracy of ramp alerts Better visibility of behind-the-meter generation and demand resources Grid resilience (local decision making)
There are several grid modernization applications that can benefit from timely, reliable, and accurate weather-monitoring and forecast data, but the challenge is to understand the requirements of weather data accuracy, quality, and reliability for these applications	Research thrust 5: Establishing requirements and optimizing weather sensing infrastructure for different smart grid applications	Develop hybrid (physics-based and data-driven) models that relate grid applications and weather-dependent parameter forecasts or state estimates Understand the impacts of different resources, varying reliability, data coverage, and sensing infrastructure cost on application performance Investigate the weather-monitoring data requirements for interdependent (or convergent) infrastructure systems (energy, fuel, gas, water and transportation)	For each application: Data reliability Maintenance budget Coverage (spatial and temporal resolutions) Forecast accuracy Total cost of sensing infrastructure ownership Data quality and retrieval Data error detection and recovery

### D.6.5 Proposed Research Thrusts and Prioritization

The working group recommended considering the sensing devices/instrumentation, data processing, communication, and system integration of direct or derived measurements as a single system to assess the gaps in the system and recommend the future research thrusts required. Because it is not enough to make just the sensing instrumentation cost-effective or reliable, the entire system should be made reliable and cost-effective for grid modernization use cases. From this perspective, the working group recommended the following structure for the Roadmap: Begin with the use cases that drive the need for sensing system innovations, and then go down to each of the unique sensing systems that enable the use cases. Under each sensing area, mention the associated high-priority research thrusts. Under such a structure, the thrusts for the weather sensing area that span device needs, as well as advanced data driven modeling and integration, would remain together.

However, given that the roadmap structure currently articulates the thrusts under devices, communication, and data-driven models as separate sections, the research thrusts identified in the weather-monitoring focus area are divided into Devices and Data-Driven Modeling or Analytics sections. Thrusts relevant to developing sensing devices for additional parameters, or integrating innovative, low-cost, or highly reliable sensors will go under the Devices section. Thrusts relevant to using sensor data for advancing physics-based weather phenomena models—including advanced forecast models and their uncertainty

characterization, harnessing disparate data, severe events data, and standardization for utility integration—will all be under the Data-Driven Modeling section. In addition to the uniqueness of the research needs for weather data integration mentioned in these sections, any apparent overall theme that may be common to other sensing areas (e.g., standardization and value proposition), is mentioned under the crosscutting initiatives.

The following seven research thrusts were identified as high in priority. They are divided into three sections.

### **Devices**

1. Integration and testing of innovative low-cost weather sensing technologies
2. Development of devices for enhanced weather observability

### **Data-driven modeling and integration**

1. Harnessing existing disparate weather- monitoring resources and enabling their optimal use
2. Advanced modeling of resource observability and forecasting
3. Integrating high-impact weather situations for grid resilience

### **Crosscutting**

1. Weather measurement standardization and quality control
2. Establishing requirements for different grid applications

Full descriptions of these research thrusts and the associated activities are given in the Roadmap. Thrusts 6 and 7 are not explicitly mentioned in the document, but they are emphasized in crosscutting initiatives in a broader generic context.

Additionally, a use case for better integration of weather data for power grid modernization is recommended for applications relevant to grid dispatch, flexibility, situational awareness, and resilience. This use case emphasizes the need and importance of efficiently integrating weather data for economic and flexible operation—on a minute-by-minute, hour-by-hour, and day-to-day basis—of future power grids with highly variable renewable penetration.

### **D.6.6 Relationship with Existing GMLC/GMI Efforts**

The proposed research thrusts are being addressed to some extent through existing efforts supported under the GMLC and the GMI, especially the thrusts related to the development of advanced forecasting models and situational awareness. Research focused on forecasting and visualization is being pursued under GMLC category 2 projects funded by the wind (Wind Technologies Office) and solar (Solar Energy Technologies Office) programs. Additionally, there was a 2017 award announcement from SETO on Solar Forecasting II<sup>30</sup> that focused on development of probabilistic solar irradiance and power forecasting, grid integration, and validation methods. A 2018 funding opportunity announcement from SETO (FOA 1840)<sup>31</sup> asked for advanced methods and validations for improving grid-edge solar observability. However, according to the gap analysis mentioned earlier and the recommended research thrusts, lower-technology readiness level R&D is needed to develop low-cost weather sensors for scalable deployment and to enhance observability, develop high-quality calibration and sensing for critical applications,

---

<sup>30</sup> <https://www.energy.gov/eere/solar/funding-opportunity-announcement-solar-forecasting-2>

<sup>31</sup> <https://www.energy.gov/eere/solar/funding-opportunity-announcement-fy-2018-solar-energy-technologies-office>

harness disparate sensing resources for optimal integration of forecasts, integrate severe weather data, improve situational awareness in energy management system and distribution management system environments, and promote standardization.

## D.7 END-USE/BUILDINGS MONITORING (LABORATORY LEAD: GUODONG LIU, ORNL)

### D.7.1 Scope of Working Group

Smart meters provide utilities with the ability to monitor the operating status of distribution systems as well as end users' energy consumption for steady-state operation. However, distributed generation and energy storage control, system dynamics, islanding, and resynchronization of microgrids/nanogrids require the deployment of much faster and higher-resolution (e.g., millisecond) sensors. These sensors should be able to provide the data needed for advanced applications, such as seamless islanding and resynchronization of microgrids. To enable optimal end-use building electric load operation and coordination with the utility distribution system, multi-component sensors that are integrated, interactive and intelligent need to be developed for comprehensive self-learning/adaptive controls, transactive energies, and so on. This working group will review currently proposed research thrusts within this focus area of the Sensing and Measurement Technology Roadmap and develop a clear understanding of the current industrial state of the art and quantitative metrics for new sensing and measurement technology development.

### D.7.2 Working Group Process

The End-Use/Buildings Monitoring Working Group established a core group of stakeholders spanning the DOE national laboratory system, academia, utilities, and vendors. The following is a full list of participants.

Name	Organization	Contact information
Eugene Song	NIST	<a href="mailto:eugene.song@nist.gov">eugene.song@nist.gov</a>
Lilian Bruce	Electric Power Board of Chattanooga	<a href="mailto:bruceb@epb.net">bruceb@epb.net</a>
Scott Averitt	Bosch	<a href="mailto:Scott.Averitt@us.bosch.com">Scott.Averitt@us.bosch.com</a>
Sumit Paudyal	Michigan Tech	<a href="mailto:sumitp@mtu.edu">sumitp@mtu.edu</a>
Tim McIntyre	ORNL	<a href="mailto:mcintyretj@ornl.gov">mcintyretj@ornl.gov</a>
Teja Kuruganti	ORNL	<a href="mailto:kurugantipv@ornl.gov">kurugantipv@ornl.gov</a>
Guodong Liu	ORNL	<a href="mailto:liug@ornl.gov">liug@ornl.gov</a>

Initially, the working group was asked to review and comment on the relevant section of the Technology Review and Assessment Document to become familiar with the current state of the art used in developing the initially proposed research thrusts within the End-Use/Buildings Monitoring area. The team was then asked to critically review and comment on the initially proposed set of research thrusts developed by the DOE national laboratory team and provide insights into potential gaps in sensor device technology. A previous roadmap of DOE's Building Technologies Office served as a reference.

Based on team member input, three key research thrusts were proposed. For each research thrust, the working group focused on the measured parameters and key metrics, including measured data resolution, measurement accuracy, and fully installed cost. The information gathered provided a basis for the key findings outlined below, including the gap analysis summary table presented in Section D.7.4.

### D.7.3 Key Findings and Recommendations

The team identified many key findings during the working group process, which led to the proposed research thrusts. A summary of the most significant gaps, the proposed approaches to address these gaps, and the linkages to proposed research thrusts appear in the summary table in Section D.7.4. Key findings include the following.

1. Many commercial technologies exist for end-use/building monitoring. Their deployment is limited by the total cost of installation. ***Federal research efforts on end-use/building monitoring should specifically target (1) dramatic reductions in cost for comparable performance to existing commercial technologies and (2) extremely low-cost sensing approaches that can enable access to parameters of interest with adequate but reduced overall performance levels.***
2. Microgrids, building microgrids, and nano-microgrids will need high-resolution current and voltage sensors for advanced control, such as islanding and resynchronization. ***Federal research efforts should target high-resolution and high- accuracy current/voltage sensors with modest cost.***
3. Wireless, self-powered, self-configuring, self-commissioning, and self-calibrating sensors for building efficiency will be necessary for future transactive controls. ***Federal research efforts should target development of low-cost, wireless, self-powered, self-calibrating sensors for large-scale deployment.***
4. Multiple building sensors (e.g., temperature, humidity, air quality) could be integrated on the same chip to lower cost and supplement intelligent building control functions. ***Federal research efforts should target multi-component, integrated, low-cost sensors for building efficiency.***
5. Electricity, temperature, luminance, air quality, building occupancy, and other values are measured by different types of equipment and typically are not correlated to perform advanced functions like fault detection and diagnosis (FDD) of building equipment. ***Federal research efforts should encourage development of multi-sensor integrated measurement devices that are self-powered, interactive, and intelligent for comprehensive self-learned/adaptive controls.***

### D.7.4 Gap Analysis Summary

Gaps identified by working group	Relevant research thrust or thrusts	Approach to address gap	Key metrics to be addressed
Building/end-use monitoring technologies exist, but deployment is limited by cost	All	Develop multi-tier metrics to balance performance/cost trade-offs  Dramatically reduce cost for existing performance and enable new lower-cost sensors with reduced performance	Performance and cost
Distribution PMUs will play a key role in distribution state estimation and system parameter correction	Research thrust 1: High-resolution building-to-grid sensors.	Develop cost-effective distribution PMU	Performance and cost
Wireless, self-powered, self-calibrating sensors for building efficiency are needed	Research thrust 2: High-accuracy and low-cost building efficiency sensors	Develop low-cost, wireless, self-powered, self-calibrating sensors for large-scale deployment	Performance and cost

Gaps identified by working group	Relevant research thrust or thrusts	Approach to address gap	Key metrics to be addressed
Self-configuring and self-commissioning systems/equipment for buildings are needed	Research thrust 2: High-accuracy and low-cost building efficiency sensors	Develop auto self-configuration and commission sensors	Performance and cost
Multi-component sensors for building efficiency are needed	Research thrust 3: Intelligent functions for integrated multi-component sensors	Develop multi-component integrated, low-cost sensors for building efficiency	Performance and cost
Closed loop and transactive-based control for building efficiency and distribution system requested service, such as load shedding and var support are needed	Research thrust 3: Intelligent functions for integrated multi-component sensors.	Develop multi-objective closed-loop control across multiple systems	Performance and cost
FDD and prognostics are needed as part of self-learning building systems	Research thrust 3: Intelligent functions for integrated multi-sensors.	Develop machine learning-based building system-scale FDD and prognostics for self-correcting controls	Performance and cost

**D.7.5 Proposed Research Thrusts and Prioritization**

Based upon the results of the working group efforts and the associated gap analysis, three major research thrusts were discussed and are highly recommended.

Research thrusts recommended

1. Development of high-resolution building-to-grid sensors (recommended)
2. Development of high-accuracy and low-cost building efficiency sensors (recommended)
3. Development of intelligent functions for integrated multi-sensors (recommended)

**D.7.6 Relationship with Existing GMLC/GMI Efforts**

The proposed research thrusts for prioritization are being addressed to some extent through existing efforts supported under the GMLC and the GMI more broadly. Research focused on high-resolution building-to-grid sensors (research thrust 1), as well as high-accuracy and low-cost building efficiency sensors (research thrust 2) is being pursued under the GMLC Advanced Sensor Development Projects (e.g., ultra PMU, optical sensors). The transactive energy program of the DOE Office of Electricity and the transactive control program of DOE’s Office of Energy Efficiency and Renewable Energy have begun supporting projects related to intelligent demand response and building controls (research thrust 3). Despite the ongoing efforts in this area within the GMLC and GMI, clear opportunities exist to expand upon the area of end-use/building monitoring to address the targeted research thrusts recommended by the working group.

## D.8 DISTRIBUTED COMMUNICATION ARCHITECTURE (LABORATORY LEADS: PETER FUHR AND MARISSA MORALES-RODRIGUEZ, ORNL)

### D.8.1 Scope of Working Group

Distributed communication has been viewed as a promising solution to tackle the challenges from large-scale deployment of distributed sensors in the future grid. This focus area targets architectural design for distributed communication and an analysis of its impact on operation and control of the electric power grid in terms of various applications. This working group reviewed the current proposed research thrusts within this focus area of the Sensing and Measurement Technology Roadmap and developed a clear understanding of the current industrial state of the art and quantitative metrics for new sensing and measurement technology development.

The Distributed Communication Architecture (DCA) working group established a core group of stakeholders spanning the DOE national laboratory system, academia, utilities, and vendors. The following is a full list of participants.

Name	Organization	Contact information
Kang Lee	NIST	<a href="mailto:kang.lee@nist.gov">kang.lee@nist.gov</a>
Jim Glass	Electric Power Board of Chattanooga	<a href="mailto:glassjb@epb.net">glassjb@epb.net</a>
Lilian Bruce	Electric Power Board of Chattanooga	<a href="mailto:brucelb@epb.net">brucelb@epb.net</a>
Stuart Laval	Duke Energy	<a href="mailto:Stuart.Laval@duke-energy.com">Stuart.Laval@duke-energy.com</a>
Nestor Camino	Schneider Electric	<a href="mailto:Nestor.Camino@schneider-electric.com">Nestor.Camino@schneider-electric.com</a>
Sterling Rooke	Brixon	<a href="mailto:ssr@brixon.io">ssr@brixon.io</a>
Yilu Liu	University of Tennessee–CURENT	<a href="mailto:liu@utk.edu">liu@utk.edu</a>
Jeff Reed	Virginia Tech	<a href="mailto:reedjh@exchange.vt.edu">reedjh@exchange.vt.edu</a>
Olga Lavrova	SNL	<a href="mailto:olavrov@sandia.gov">olavrov@sandia.gov</a>
Emma Stewart	LLNL	<a href="mailto:Stewart87@llnl.gov">Stewart87@llnl.gov</a>
Penny Chen	Yokogawa Electric Company	<a href="mailto:penny.chen@us.yokogawa.com">penny.chen@us.yokogawa.com</a>
Peter Fuhr	ORNL	<a href="mailto:fuhrpl@ornl.gov">fuhrpl@ornl.gov</a>
Marissa Morales-Rodriguez	ORNL	<a href="mailto:moralesme@ornl.gov">moralesme@ornl.gov</a>

Of note is the interplay that occurred among a variety of sensor- and communication-related GMLC working groups and the design of an integrated communication fabric that supports the operational requirements associated with those groups' activities. In parallel, there is need for a significantly enhanced cybersecurity profile for the communication system. Discussions with DOE-sponsored cyber researchers continue to examine the latest trends in security hardware and software intended for industrial control systems in general and grid modernization specifically. Coupled with this cybersecurity focus is an examination of the scale of realistically deployable network topologies in utilities of varying sizes and sophistications, ranging from cooperatives (Flathead Electric Co-op, Lake Region Electric Co-op) through municipally owned utilities (Electric Power Board of Chattanooga [EPB], Knoxville Utilities Board), to larger utilities (Tennessee Valley Authority [TVA] and Duke Energy). Of further significance is the role that the Industrial Internet of Things (IIoT) and distributed energy resources (DER) can (inter)play in terms of sensing and control signals. The possibilities presented by both technology arenas are noteworthy, as is the need for a communication fabric that may rely on more out-of-band signaling than traditional supervisory control and data acquisition (SCADA) networks.

## D.8.2 Working Group Activities

The DCA working group gathered a variety of communication architectures that vendors are proposing—or have sold—to electric utilities specifically and energy delivery system end users in general. While many such architectures are being promoted, there are four fundamental underpinnings to a next-generation grid-centric distributed communication architecture that need to be addressed:

1. **IIoT/IoT.** The IIoT is a specialized IoT implemented in rugged packages suitable for industrial application environments. In fact, legacy industrial control devices, such as programmable logic controllers, will be compatible at least temporarily with the IIoT. The IIoT benefits from data flowing through standard-based and common networks. From a networking standpoint, IIoT systems will break the ongoing practice of using proprietary networks and bring into place a common standard-based networking technology. The convergence of the IT technology and OT operations knowledge for industrial automation environments is well under way. Soon, the IIoT will approach the network edge for almost every industrial application. IIoT installations can include hundreds or even thousands of sensors across a large facility. Numerous devices labeled IoT for home/building automation cross the boundary with utility operations with varying levels of communication technology and intersect with utility communication systems. Of special note are the waves of devices that are directly IP-addressable<sup>32</sup>. This class of IoT/IIoT devices flattens the SCADA and SP95/ICS (industrial control system) architectures (see Figure D.1). In-network, IP-addressable edge devices place additional operational requirements on a utility's intrusion detection system/intrusion prevention system/unified threat management cybersecurity software system. Current IIoT/IoT offerings to electric utilities and their associated communication and networking requirements<sup>33</sup> are being assessed in conjunction with EPB.

---

<sup>32</sup> Such devices have received many labels, including “edge devices,” “end devices,” and “edge network appliances.” Regardless of the name, they are directly IP addressable (as opposed to a network topology that has the devices, sensors, and grid elements behind a gateway).

<sup>33</sup> Networking topologies, core communication technologies, associated communication architectures.

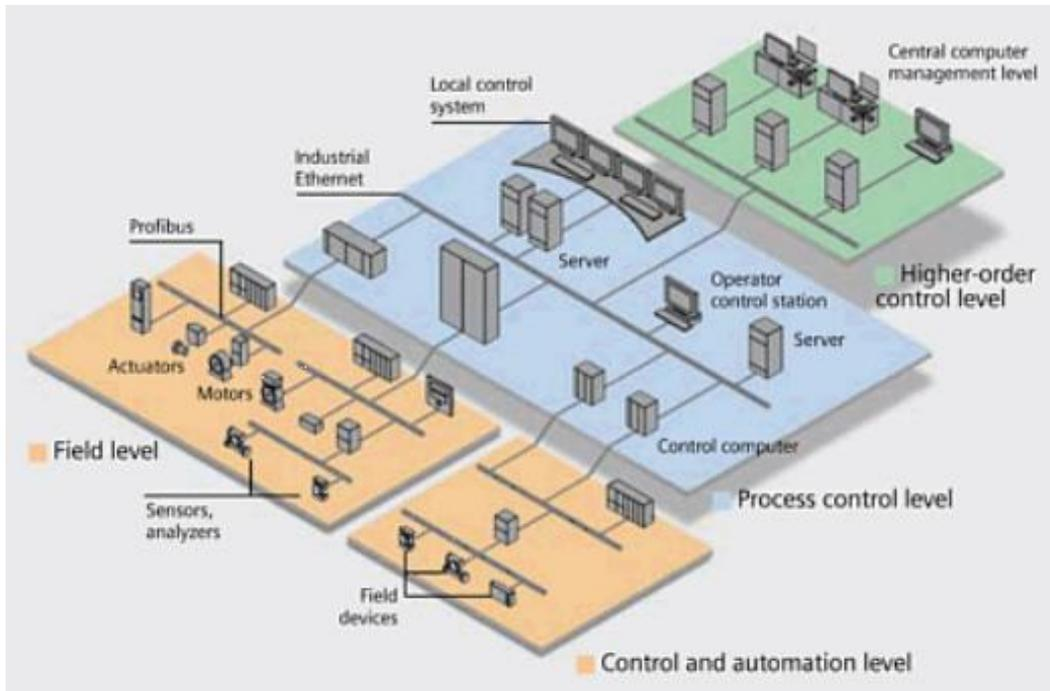

Figure D.1. SCADA/ICS designs for networked control and automation system architectures as shown here rely on separation of functionality and components. Many instrumentation standards, including SP88, SP95, and SP99, rely on such separations.

2. **Wireless, frequency congestion (shared spectrum).** Many sensors and systems identified in 1, as well as their possible deployment within the utility grid of service systems, rely on wireless communication. A significant portion of current wireless sensing/monitoring/control products being offered to the utilities by large and small vendors rely on operations within the (license-free) industrial, scientific and medical (ISM) frequency bands. Frequently, the information coming from such sensors and systems is “offered with cloud capability,” meaning that some level of IT connectivity is required. The (essentially) singular worldwide 2.4 GHz ISM frequency band exhibits significant frequency congestion issues with WiFi, Bluetooth, and a wide array of proprietary protocols all operating in that band. Anecdotal evidence provided by a few utilities—via discussions with key personnel—reveals that utilities with many wireless devices, systems, and a communication fabric deployed throughout their infrastructure are experiencing performance variation/degradation due to this “spectrum crunch.”

On a related theme, 5G wireless is designed to have a very wide application space with three key application domains: enhanced mobile broadband, massive machine-type communications, and ultra-reliable and low-latency communications. The proposed network architectures for large- and small-cell 5G infrastructure to support massive machine-type and ultra-reliable communications are key features of NB-IoT,<sup>34</sup> which will be deployed in 5G. Low latency (and very high) data rate communication is the expectation. The 5G application space as envisioned by the International Telecommunications Union (ITU) is shown in Figure D.2.

<sup>34</sup> Where, for example, a simple 5G small-cell “system” may be established over a utility substation, thereby providing wireless connectivity from devices to the 5G cellular server (not necessarily a telecommunications company). The 5G server is integrated into the utility’s backbone core for delivery of sensor information to the SCADA system via that core transport. Such a system architecture is being designed with and for EPB’s use of wireless IIoT sensors and systems within their substations and on unmanned aerial vehicles (drones).

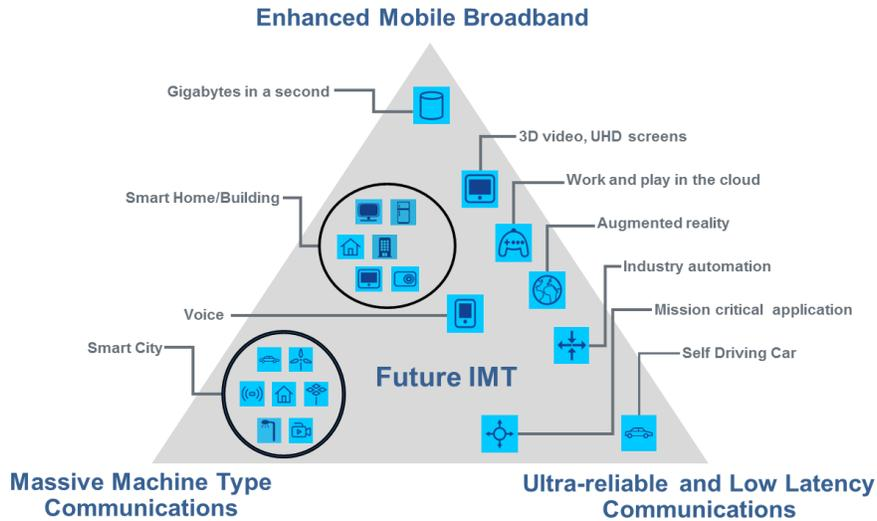

Figure D.2. Example applications as envisioned by the ITU for 5G.

The DCA working group leveraged the ongoing efforts of the Office of Science and Technology Policy (OSTP) Networking and Information Technology Research and Development (NITRD) Wireless Spectrum Research and Development group (WSRD) examining the use of shared spectrum to obviate the spectrum crunch (Figures D.3 and D.4). Through the monthly WSRD meetings, as well as conferences like the International Symposium Advanced Radio Technology (ISART 2017, Boulder, CO, August 2017) and the DOE-sponsored Interagency Spectrum Summit (DOE, Washington, DC, June 2017) the DCA working group accumulated and distilled relevant information on current and future networking and architectures and requirements.

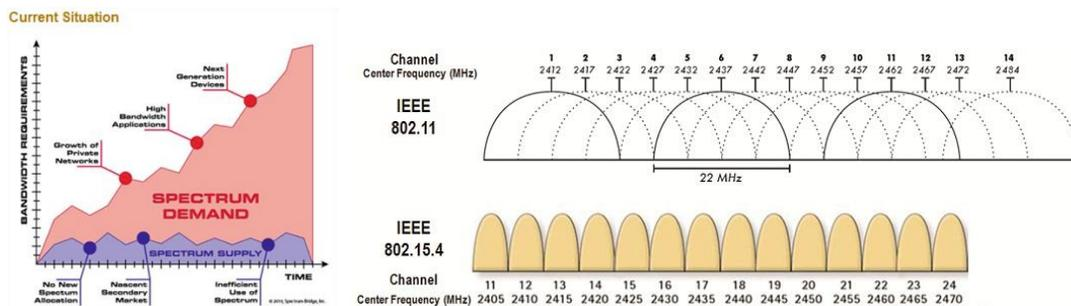

Figure D.3. Frequency congestion showing continual requests for “more spectrum” and channel assignments for 802.11 and 802.15.4 compliant transceivers in the 2.4 GHz band.

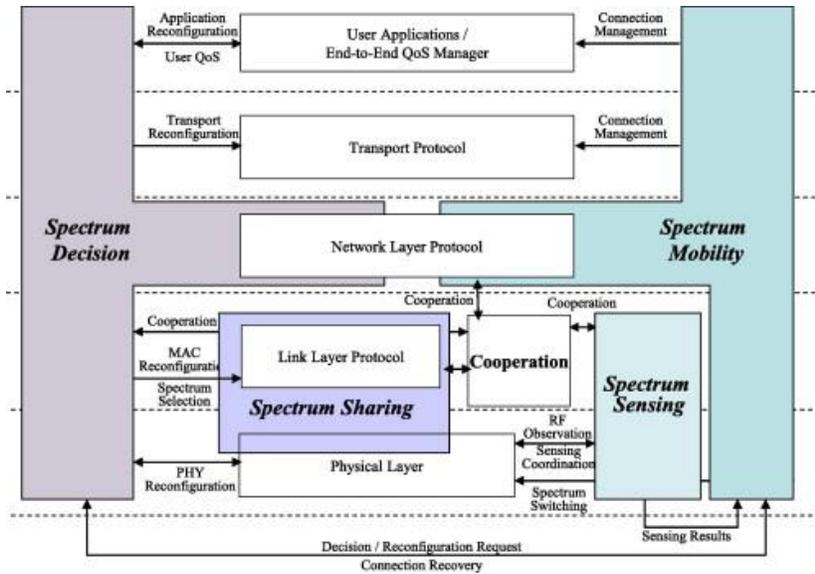

Figure D.4. Shared spectrum would require that additional intelligence/capabilities be programmed into advanced sensors with an associated flexible communication network fabric.

3. **Cybersecurity and cyber-physical security.** Security of devices, sensors, control elements, and related utility components is of paramount concern. In addition to the vendor information gathered, the DCA working group reviewed best practice guides; DOE, NIST, and other recommended architectures; network security functions and features; and DOE-OE’s DarkNet designs to present a fall 2017 snapshot of cybersecurity and cyber-physical security activities most relevant to electric utilities in general. Documents reviewed include those listed in Table D.1.

**Table D.1. Various organizations have released—or offer—various communication architecture designs and recommendations such as these.**

Electricity Subsector Supply Chain Test, Training, Standards and Certification Organizations (Preliminary)																					
Features, Capabilities, Competencies, Responsibilities, and Authority - Related to Cybersecurity of the Electricity Subsector Supply Chain																					
Organization, Program or Activity	Recognized National or International Standards or Regulations Creation Body	Regulates, Monitors and Enforces	Imposes Penalties for Non-Compliance	Monitors, Inspects, Licenses and Regulates Energy Sector Projects	Standards-Based Device Test & Accreditation	Cyber-Security Research, Test, Development & Validation Laboratory	Awareness Programs	Cybersecurity Incident Response	Mitigation and Recovery Planning	Vulnerability Assessments	Personnel Risk Assessment & Accreditation	Personnel CIP Cyber-Security Training	Personnel CIP Physical Security Training	Personnel CIP Operational Security (General) Training	Research for Future CIP Solutions	Energy Supply Chain Focused	Funds Independent Research	Publications Posted on Public or Members-Only Website	Periodic Newsletter to Members and/or Industry	Energy CIP Workforce Development Programs	
<b>FERC</b>																					
- Existing Capability	✓	✓	✓	✓	✓	✗	✓	✗	✗	✗	✗	✗	✗	✗	✗	✓	✓	✓	✓	✗	
<b>NERC</b>																					
- Existing Capability	✗	✓	✓	✓	✓	✓	✓	✓	✓	✓	✓	✓	✓	✓	✓	✓	✓	✓	✓	✓	✓
<b>IEC</b>																					
- Existing Capability	✓	✗	✗	✗	✓	✓	✓	✗	✗	✓	✗	✓	✗	✓	✓	✓	✓	✓	✓	✓	✓
<b>ISA Secure</b>																					
- Existing Capability	✓	✗	✗	✗	✓	✓	✓	✗	✗	✓	✓	✓	✗	✓	✓	✓	✓	✓	✓	✓	✓
<b>Underwriters Laboratories</b>																					
- Existing Capability	✓	✗	✗	✗	✓	✓	✓	✗	✗	✓	✗	✓	✗	✓	✓	✗	✓	✓	✓	✓	✓
<b>NIST</b>																					
- Existing Capability	✓	✓	✓	✓	✓	✓	✓	✗	✓	✗	✗	✓	✗	✗	✓	✗	✓	✓	✓	✓	✓
<b>DOE/OE ES-C2M2 Cybersecurity Capability Maturity Model</b>																					
- Existing Capability	✓	✗	✗	✗	✗	✓	✓	✓	✓	✗	✗	✓	✗	✓	✓	✓	✗	✓	✗	✓	✓

4. **Evaluation of various grid architectures.** Activities concentrated on reviewing DER microgrid designs and architectures including both AC and DC microgrid architectures (see Figure D.5). Numerous meetings were held with a variety of complexity and capability utilities. One of these was

a technical “deep dive” regarding EPB’s architecture for the implementation of GMLC advanced sensors. This activity included investigations into network architecture(s) designed for cybersecure, timely restoration of a DER microgrid-centric electric grid. This specifically examined the communications architecture necessary for a sensor-laden, microgrid-centric architecture with a variety of grid assets. The working group concentrated on a scalable sensing and control companion communications network that may have subtle changes based on asset mixes.

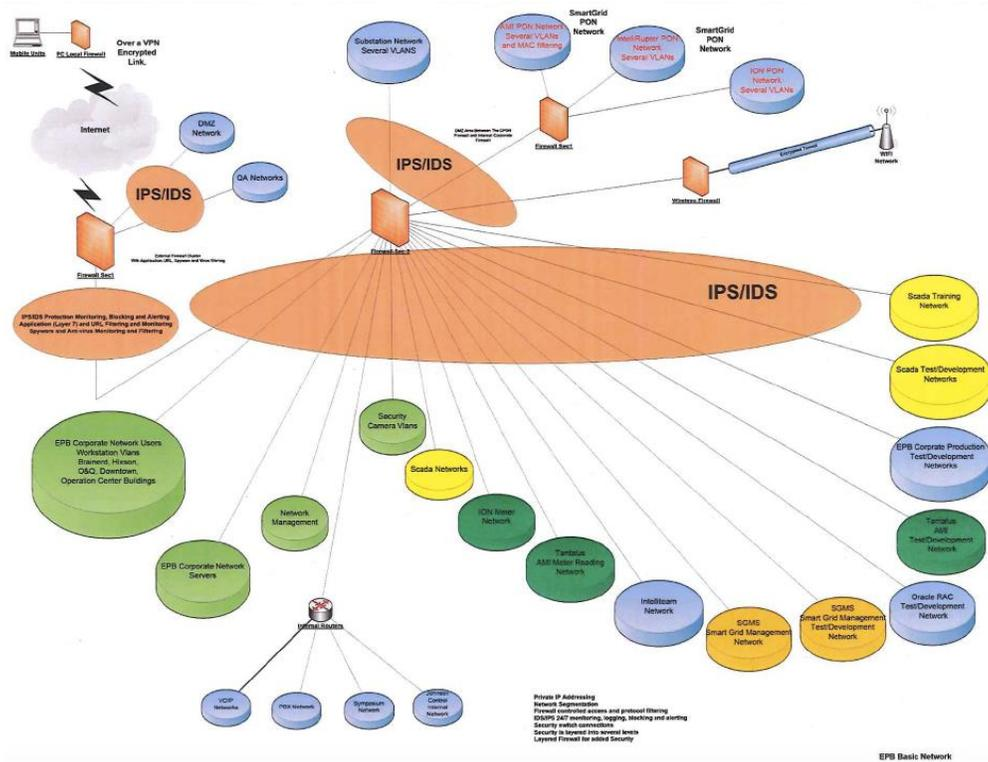

Figure D.5. The cyber and connectivity architectures used at EPB. Source: EPB.

### D.8.3 Key Findings and Recommendations

The team identified many key findings during the working group process, which informed the subsequent recommendation about proposed research thrusts. A summary of the most significant identified gaps, the proposed approaches to address the gaps, and their linkages to proposed research thrusts can be found in the summary table in Section D.8.4. Key findings include the following:

1. Utilities, obviously, have a deployed communication network that supports their operations. ***Federal research efforts on design and development of a cost-effective, scalable communications fabric to support the wide range of next generation sensors, systems, and DER components are being explored.***
2. The IIoT and 5G wireless activities under way in the private, public, and academic sectors present an array of concerns for electric utilities, including changes in the SCADA/ICS architecture, cybersecurity vulnerabilities presented by the deployment of such devices, and use of “the Cloud” for data archiving and operations. ***Federal research efforts to design a distributed communications architecture that supports these technology developments are under way.***

- Electrical parameter measurements can provide the most rapid signatures of low-probability, high-consequence events, such as man-made or natural events, to enable actions that can prevent large-scale failures and minimize the impacts to increase grid resiliency. ***Federal research efforts should target the development of a scalable, rapid, high-bandwidth and low-latency communications network to support cybersecure transport electrical parameter measurements.***

#### D.8.4 Gap Analysis Summary

Gaps identified by working group	Relevant research thrust or thrusts	Approach to address gap	Key metrics to be addressed
Current architectures are inadequate for advanced security and authentication protocols (e.g., Open FMB, ICCP V2).	All	Investigate array of sensors for utility R&D and product development activities. Identify throughput and latency requirements for sensors platforms (as opposed to individual specific sensors)	Performance and cost
Implications of varying IoT/IIoT devices, sensors, and systems for deployment throughout utility networks (including residences)	All	Develop compendium of IoT/IIoT vendors' and industrial groups' recommended architectures	IoT attack surface variation based on ad hoc and at-scale deployment of IoT/IIoT
Spectrum congestion	All	Continue discussions with OSTP/NITRD/ WSRD regarding other agencies' activities	Performance, latency, bandwidth
5G cellular integration into utility communication network architecture	All	Hold meetings with utilities (EPB, Duke, TVA, Sempra, National Rural Electric Cooperative Association) regarding their future plans for wireless sensors. Examine DarkNet cyberphysical network topology for applicability to GMLC. Continue work with Virginia Tech ( <a href="#">Wireless@VT</a> ) program	5G integration points within utilities' existing cybersecurity structure
Multiple data transport users on a shared medium. Intertwined communications performance and cybersecurity across differing layered network topologies	All	Reexamine the wide array of best practice guides to industrial control systems (ICS/SCADA). Update as necessary, then vet with WSRD	Latency, reliability, security (integration into utility cyber operations), ease of utility use

#### D.8.5 Proposed Research Thrusts and Prioritization

Based upon the results of the working group efforts and the associated gap analysis, three different research thrusts were developed for consideration and discussion. Of these research thrusts, all are being recommended for prioritization. The full description of the research thrusts can be found in the document.

Research thrusts developed

1. Develop compendium of (principal) IT/OT network architectures (recommended)
2. Spectrum management, 5G, and cybersecurity (recommended)
3. Integration with multiple project sensor development and distribution grid asset working groups (recommended)

#### **D.8.6 Relationship with Existing GMLC/GMI Efforts**

Multiple projects involve developing sensors and systems with varying time scales and measurement transport requirements. There needs to be a collation of these projects related to architecture needs and communication backbone implications (wireless, wired, optical). The key measurement parameters are latency, data throughput, multiple communication technology integration ported to utility network fabric, and SCADA core.

### **D.9 COMMUNICATION AND NETWORKING TECHNOLOGY (LABORATORY LEAD: CHEN CHEN, ANL)**

#### **D.9.1 Scope of Working Group**

Rapid development of new communication technologies in the communication community, especially the IoT and 5G, present leveraging opportunities for grid modernization related to large-scale deployment of distributed sensors. New networking technologies can also be used to address the challenges of scalability, diverse quality of service (QoS) requirements, efficient network management, and reliability and resilience. Another major challenge for the grid modernization effort is the interoperability among diverse equipment and standards. This working group reviewed the current proposed research thrusts within this focus area of the Roadmap and developed a clear understanding of the current industrial state of the art and quantitative metrics for new sensing and measurement technology development.

#### **D.9.2 Working Group Process**

The Communication Technology working group established a core roster of stakeholders spanning the DOE national laboratory system, international research institutions, consultants, standardization entities, and vendors. The following is a full list of participants.

<b>Name</b>	<b>Organization</b>	<b>Contact Info</b>
Eugene Song	NIST	<a href="mailto:eugene.song@nist.gov">eugene.song@nist.gov</a>
Kang Lee	NIST	<a href="mailto:kang.lee@nist.gov">kang.lee@nist.gov</a>
Bin Hu	NIST	<a href="mailto:bin.hu@nist.gov">bin.hu@nist.gov</a>
Chen Chen	ANL	<a href="mailto:morningchen@anl.gov">morningchen@anl.gov</a>
Scott Averitt	Bosch	<a href="mailto:Scott.Averitt@us.bosch.com">Scott.Averitt@us.bosch.com</a>
Larry Lackey	Coergon (Consultant)	<a href="mailto:larry.lackey@outlook.com">larry.lackey@outlook.com</a>
Bob Heile	Wi-Sun Alliance	<a href="mailto:bheile@ieee.org">bheile@ieee.org</a>
Di Shi	Global Energy Interconnection Research Institute North America (GEIRINA)	<a href="mailto:di.shi@geirina.net">di.shi@geirina.net</a>
Philip Top	LLNL	<a href="mailto:top1@llnl.gov">top1@llnl.gov</a>

Initially, the working group was asked to review and comment on the relevant section of the Technology Review and Assessment Document to become familiar with the current state of the art used in developing the initially proposed research thrusts within the Communication Technology area. The team was then asked to critically review and comment on the initially proposed set of research thrusts developed by the DOE national laboratory team and to provide insights into potential gaps that exist in terms of communication technology within this area.

Based on team member input, a decision was made to refocus potential research thrusts based upon an industry requirements orientation. The full list of the modified set of potential research thrusts to be considered appears within the report. The team developed a set of quantitative metrics for communication technology in sensing and measurement, including reliability, latency, scalability, security, ease of deployment and further upgradability, cost-effectiveness, QoS, dynamic network services, and others. These metrics provided a basis for the key findings outlined in this section, including the gap analysis summary table.

### **D.9.3 Key Findings and Recommendations**

The team identified many key findings during the working group process. A summary of the most significant identified gaps, the proposed approaches to address the gaps, and their linkages to proposed research thrusts appears in the summary table in Section D.9.4. Key findings include these:

1. There is a channel congestion challenge from current devices using scheduling mechanisms based on fixed/deterministic/periodic or listen-before-talk schemes, and interference caused by operation of non-interoperable devices. The challenge was created because most of the sensor-based solutions use specific radios to communicate, as well as spectrum under-utilization. ***Federal research efforts should (1) target distributed scheduling schemes that require distributed intelligence and common communication paradigms for the network to operate autonomously and (2) use radios that can support multiple technologies so that the devices can potentially get more information about the type of data transfer.***
2. Currently, not many IoT technologies can support 1 ms latency with >99% reliability to satisfy grid applications. ***Federal research efforts should (1) identify needs and present requirements in the standard body of emerging communications (e.g., 5G technique), (2) investigate distributed intelligence to reduce information flow, (3) investigate key 5G techniques (e.g., ultra-dense network, millimeter waves) and existing IoT-related techniques (e.g., machine-to-machine communication, edge computing), and (4) identify the performance gap of those techniques for smart grid communication.***
3. There is a need to keep the development cost low while supporting future upgradability to newer technologies. ***Federal research efforts should target development of an agnostic solution to the communication technology supporting intelligent, autonomous, and cooperating devices.***
4. The scalability issue should be addressed to enable networking of millions of nodes. Dynamic resource allocation and controlling network features in runtime, and plug-and-play functionalities on the device level, are necessary. ***Federal research efforts should investigate distributed intelligence and architecture and develop a smart connectivity manager to enable various intelligent decision-making (e.g., routing, channel condition aware, self-healing). Application development/resource allocation needs to be done independently of communication technology.***
5. Uncertainties and security risks caused by networking techniques should be considered. ***Federal research efforts should quantify uncertainties and security risks in the smart grid context and***

*develop self-healing and more robust capabilities to oppose malicious operations (e.g., employ cooperative security schemes to identify malicious operation/nodes).*

6. Existing co-simulation platforms with integration and interoperability abilities should be leveraged. *Federal research efforts should leverage the existing platforms from the following aspects: integrative, reconfigurable, reproducible, scalable, and usable.*

#### D.9.4 Gap Analysis Summary

Gaps identified by working group	Relevant research thrust or thrusts	Approach to address gap	Key metrics to be addressed
Channel congestion challenges from current devices using scheduling mechanisms based on fixed/deterministic/periodic or listen-before-talk schemes	Research thrust 1: Efficient spectrum utilization with interference management	Investigate distributed scheduling schemes that require distributed intelligence and common communication paradigms for the network to operate autonomously	Reliability, spectrum utilization, throughput
Interference caused by operation of non-interoperable devices, because most of the sensor-based solutions use specific radios to communicate	Research thrust 1: Efficient spectrum utilization with interference management	Use machine learning at device level to predict use of channels by interfering devices. Use radios that can support multiple technologies so that a device can potentially get more information about data transfer	Interference management to acceptable signal-to-noise ratios
Spectrum under-utilization for smart grid applications	Research thrust 1: Efficient spectrum utilization with interference management	Investigate how to define and determine primary users/applications and secondary users/applications for spectrum sharing techniques. Investigate whether existing spectrum sensing/sharing techniques support diversified performance requirements of smart grid applications, as well as performance needs of cyber-physical systems that will co-exist with smart grid. Study how to increase the spectrum utilization by sharing the spectrum/network resources across modern grid applications and how to maximize the overall network utility while satisfying the performance requirements for individual applications	Spectrum utilization
Not many IoT technologies can support 1ms latency with >99% reliability	Research thrust 2: Leverage IoT technologies in power system communications	Identify needs and present requirements in the standard body of emerging communications (e.g., 5G technique). Investigate distributed intelligence to reduce	End-to-end latency, reliability

Gaps identified by working group	Relevant research thrust or thrusts	Approach to address gap	Key metrics to be addressed
		information flow. Investigate key 5G techniques (e.g., ultra-dense network, millimeter waves) and existing IoT-related techniques (e.g., machine-to-machine communication, edge computing) and identify the performance gap of those techniques for smart grid communication	
Keep the development cost low and support future upgradability of newer technologies.	Research thrust 3: Cost-effectiveness analysis of deploying new communication technologies	Develop a solution-agnostic solution to the communication technology for supporting intelligent, autonomous and cooperating devices	Ease of deployment and future upgradability, cost-effectiveness
Address the scalability issue	Research thrust 3: Cost-effectiveness analysis of deploying new communication technologies Research thrust 4: Networking technologies for scalability issue while satisfying diverse QoS requirements.	Investigate distributed intelligence and architecture. Development of smart connectivity manager to enable various intelligence decision-making (e.g., routing, channel condition aware, self-healing). Application development /resource allocation needs to be done independently of the communication technology	Scalability, QoS support
Dynamic resource allocation and controlling network features in runtime, and plug-and-play functionalities on device level	Research thrust 5: Efficient network management to support new and dynamic services	Develop smart connectivity manager and enable a radio-agnostic design of applications	Supporting dynamic network services, supporting adaptive scheduling and resource allocation
The uncertainties and security risks caused by networking techniques	Research thrust 2: Leverage IoT technologies in power system communications. Research thrust 6: Reliability and resilience enabled by networking technologies. Research thrust 7: Identification of requirements and use cases from sensing and measurement perspective	Quantify the uncertainties and security risks in the smart grid context Employ dynamic routing enabled by smart connectivity manager Employ smart connectivity manager to enable self-healing and more robustness against malicious operations (can employ cooperative security schemes to identify malicious operation/nodes)	Reliability, resilience, security
Use case identification for Open FMB from sensors perspective	Research thrust 7: Identification of requirements and use cases from sensing and	Clustering of use cases based on sensors and/or requirements will be helpful	Comprehensive list of use cases and requirements in sensing and

Gaps identified by working group	Relevant research thrust or thrusts	Approach to address gap	Key metrics to be addressed
	measurement perspective		measurement of smart grids
How to choose networking technology to use to forward data (when many options are available) in OpenFMB	Research thrust 7: Identification of requirements and use cases from sensing and measurement perspective	A smart connectivity manager makes the network intelligent and autonomous. This layer can also be a subset of the OpenFMB interface layer	Message exchangeability and message conformity to the standards
Leverage existing co-simulation platforms with integration and interoperability abilities	Research thrust 8: Large-scale co-simulation of cyber-physical system integrating interoperability solution	Leverage the existing platforms from the following aspects: integrative, reconfigurable and reproducible, scalable, and usable	Heterogeneous hardware such as fiber, copper, power line carrier, mesh networks, point-to-point radios, LTE cellular; maybe in the future add GHz cellular, suitability for the distributed architecture, adaptability to use cases regarding sensing and measurements

### D.9.5 Proposed Research Thrusts and Prioritization

Based upon the results of the working group efforts and the associated gap analysis, a total of eight different research thrusts were developed for consideration and discussion. To minimize overlap with other focus areas, this number was condensed and reduced to five different research thrusts. Of these research thrusts, four were recommended for prioritization.

Research thrusts developed (initial):

1. Efficient spectrum utilization with interference management
2. Leverage IoT technologies in power system communication
3. Cost-effectiveness analysis of deploying new communication technologies
4. Networking technologies to address scalability issue while satisfying diverse QoS requirements
5. Efficient network management to support new and dynamic services
6. Reliability and resilience enabled by networking technologies
7. Identification of requirements and use cases from sensing and measurement perspective
8. Large-scale co-simulation of cyber-physical system integrating interoperability solution

Research thrusts developed (after combining with other working groups):

- 1) Leverage IoT technologies in power system communication (recommended)
- 2) Networking technologies for scalability issue while satisfying diverse QoS requirements (recommended)
- 3) Efficient network management to support new and dynamic services

- 4) Reliability and resilience enabled by networking technologies (recommended)
- 5) Large-scale co-simulation of cyber-physical system integrating interoperability solution (recommended)

### D.9.6 Relationship with Existing GMLC/GMI Efforts

The proposed research thrusts for prioritization are being addressed to some extent through existing efforts supported under the GMLC and the GMI more broadly. Research focused on large-scale co-simulation of cyber-physical system integrating interoperability solution (research thrust 8) is being pursued under the GMLC project Development of Integrated Transmission, Distribution, and Communication (TDC) Models, which integrates simulators designed for separate TDC domains to simulate regional and interconnection-scale power system behaviors at unprecedented levels of detail and speed. Another related project is the GMLC CyDer project, Cyber Physical Co-Simulation Platform for Distributed Energy Resources in Smart Grid, which develops a modular and scalable tool combining transmission and distribution system simulation, data collection and analysis, power generation and load forecasting, load flexibility, and real-time control of solar PV. Despite the ongoing efforts in this area within the GMLC and GMI, a clear opportunity exists to expand upon the area of communication technology to address the targeted research thrusts recommended by the working group.

## D.10 DATA ANALYTICS (LABORATORY LEAD: EMMA STEWART, LLNL)

### D.10.1 Scope of Working Group

Evaluation and maintenance of grid health currently depends on a centralized, deterministic approach in which data are collected and analyzed, and some control action is then taken. In contrast to traditional centralized grid data monitoring and analysis, building component health relies on a decentralized analytic approach in which each building component is monitored and analyzed individually. Mere availability of more data will not, by itself, lead to changes in grid visibility, security, and resiliency. To create the predictive and prescriptive environment required to enable new markets and transactions for customer revenue and a reliable grid, the data must be collected, organized, evaluated, and analyzed using sophisticated pattern detection (i.e., incipient failure analysis can have subtle signatures recognizable only by advanced analytics). Discovery algorithms can provide actionable information, allowing operators and customers to reliably manage an increasingly complex grid.

This working group reviewed the current proposed research thrusts in the sensing and measurement focus area and developed a clear understanding of the current industrial state of the art and quantitative metrics for new analytics development along with the backbone of new sensors.

### D.10.2 Working Group Process

The following is a full list of participants.

Name	Organization	Contact information
Alireza Shahsavari	University of CA–Riverside	<a href="mailto:ashah023@ucr.edu">ashah023@ucr.edu</a>
Gordon Mathews	University of CA–Riverside	<a href="mailto:ghmatthews@bpa.gov">ghmatthews@bpa.gov</a>
Jim Glass	Electric Power Board of Chattanooga	<a href="mailto:glassjb@epb.net">glassjb@epb.net</a>
Jouni Peppanen	EPRI	<a href="mailto:jpeppanen@epri.com">jpeppanen@epri.com</a>

Name	Organization	Contact information
Junbo Zhao	NASPI Distribution Task Team/PNNL	<a href="mailto:junbobzhao@gmail.com">junbobzhao@gmail.com</a>
Lilian Bruce	Electric Power Board of Chattanooga	<a href="mailto:brucelb@epb.net">brucelb@epb.net</a>
Lingwei Zhan	ORNL	<a href="mailto:zhanl@ornl.gov">zhanl@ornl.gov</a>
Mahendra Patel	EPRI/ formerly with PJM	<a href="mailto:mpatel@epri.com">mpatel@epri.com</a>
Reza Arghandeh	FSU–Center for Advanced Power Systems	<a href="mailto:reza@caps.fsu.edu">reza@caps.fsu.edu</a>
Sascha von Meier	NASPI Distribution Task Team	<a href="mailto:vonmeier@berkeley.edu">vonmeier@berkeley.edu</a>
Scott Averitt	Bosch	<a href="mailto:Scott.Averitt@us.bosch.com">Scott.Averitt@us.bosch.com</a>
Emma Stewart	LLNL	<a href="mailto:stewart78@llnl.gov">stewart78@llnl.gov</a>
Neelofar Anjum	PG&E	<a href="mailto:NXAU@pge.com">NXAU@pge.com</a>
Lillie Alvarez	RPU	<a href="mailto:lalvarez@riversideca.gov">lalvarez@riversideca.gov</a>
Venkat Shastri	USD	<a href="mailto:venkat@sandiego.edu">venkat@sandiego.edu</a>
Sean Murphy	Ping Things	<a href="mailto:Sean@pingthings.io">Sean@pingthings.io</a>

Initially, the working group was asked to review and comment on the relevant section of the Technology Review and Assessment Report and was provided existing material developed by the project national laboratory team.

Based on team member input, a decision was made to refocus potential research thrusts around metrics for future analytics and a gap analysis of the existing spread of analytics as it pertains to the field of electric grid analysis. The team established a matrix and relevant metrics within the matrix, spanning grid levels and data analysis types. The data distribution levels considered were locally distributed and centralized, and the time frames of analytics were past, present, and forward-looking. A survey of the existing and future state-of-the-art of data analysis was considered in creating the metrics. Vendors were specifically requested to provide input.

### D.10.3 Key Findings and Recommendations

The team identified two key areas during the working group process that led to the proposed research thrusts. A summary of the most significant identified gaps, the proposed approaches to address the gaps, and their linkages to proposed research thrusts appear in the summary table in Section D.10.4. Key findings include these:

1. Data preparation is a key limitation for data analysis and should be considered as a key gap within data analytics, rather than the analytics themselves.
2. Multimodal and multivariate analyses, integrating new sensing types and considering synchronization and reconciliation of these data sets, would be a valuable contribution.

#### D.10.4 Gap Analysis Summary

Gaps identified by working group	Relevant research thrust or thrusts	Approach to address gap	Key metrics to be addressed
Grid asset monitoring technologies exist, but deployment is limited by cost	All	Develop analytics to leverage new data sources efficiently	Performance and cost
Non-localized signatures of failures or faults are difficult to detect with individual sensors	Research thrust 2: Multimodal multivariate algorithms	Develop analytics that use disparate data sources for fault location and identification	Areal or linear spatial resolution, performance, cost
Electrical parameters can provide the most rapid signatures of low-probability, high-consequence events, such as human or natural threats (e.g., geomagnetic disturbance, electromagnetic pulse)	All	Deploy analytics with existing and emerging electrical parameter measurements	Performance, latency, bandwidth and cost
Data-driven analysis is siloed by sensor and data type and does not leverage the full range of data available for maximal efficiency and lowest cost	Research thrust 2: Multimodal multivariate algorithm development	Present use cases in a multi-sensor domain. Develop and demonstrate multimodal, multivariate machine learning techniques for real-time and predictive analysis of a wide range of grid conditions, as presented in the use cases	Reliability, correctness, cost, accuracy, data acquisition latency, computational budget, precision, scalability
Data quality from new and existing sensors drives the application and usefulness of the algorithms and is a critical issue. This issue is often considered solved by industry, but it returns as a critical issue, often after deployment	Research thrust 1: Data preparation (validation, quality assessment, conditioning/correction)	Develop consistent metrics and methodology to evaluate the impact of data quality on the range of algorithms across the grid and analytics domains	Latency, reliability, correctness, cost

#### D.10.5 Proposed Research Thrusts and Prioritization

Based upon the results of the working group efforts and the associated gap analysis, two prioritized research thrusts have been developed for consideration and discussion.

Research thrusts developed:

- 1) Data preparation (validation, quality assessment, conditioning/correction)
- 2) Multimodal multivariate algorithms

#### D.10.6 Relationship with Existing GMLC/GMI Efforts

The proposed research thrusts for prioritization are being addressed to some extent through existing efforts supported under the GMLC and, more broadly, the GMI with research focused on distributed

analytics (1.4.9) and under projects within DOE SETO (VADER, CyDER). Despite the ongoing efforts in this area within the GMLC and GMI, a clear opportunity exists to expand upon the area of data analytics to address the targeted research thrusts recommended by the working group.

## **D.11 DATA MANAGEMENT (LABORATORY LEAD: PHILIP TOP, LLNL)**

### **D.11.1 Scope of Working Group**

The power grid is becoming more highly networked as it transitions to a modern power system with key features such as two-way power flow. Because of this high degree of connectivity, there is a significant increase in both the volume and variety of data being created to monitor and control the system. These data represent a significant opportunity for existing and future applications that can intelligently operate on such a diverse data set; but for these applications to be successful, the data must be maintained in a coherent fashion. Two key challenges in this area are access to data and the data organization. Efficient and accurate data management systems must be in place to ensure that the data are distributed where needed in an on-time and reliable fashion, and the results are consistent and accurate. This working group reviewed the current proposed research thrusts within the relevant sensing and measurement technology roadmap focus areas and developed a clear understanding of the current industrial state of the art and quantitative metrics for new sensing and measurement technology development.

### **D.11.2 Working Group Process**

The Data Management working group established a group of stakeholders who have expertise and are interested in various components of the topic area. The following is a list of participants.

<b>Name</b>	<b>Organization</b>	<b>Contact information</b>
Lilian Bruce	Electric Power Board of Chattanooga	<a href="mailto:brucealb@epb.net">brucealb@epb.net</a>
Lingwei Zhan	ORNL	<a href="mailto:zhanl@ornl.gov">zhanl@ornl.gov</a>
Mahendra Patel	PJM	<a href="mailto:mpatel@epri.com">mpatel@epri.com</a>
Junbo Zhao	Virginia Tech	<a href="mailto:zjunbo@vt.edu">zjunbo@vt.edu</a>
Alireza Shahsavari	University of CA–Riverside	<a href="mailto:ashah023@ucr.edu">ashah023@ucr.edu</a>
Reza Arghandeh	Florida State University	<a href="mailto:r.arghandeh@fsu.edu">r.arghandeh@fsu.edu</a>
Scott Averitt	Bosch	<a href="mailto:Scott.Averitt@us.bosch.com">Scott.Averitt@us.bosch.com</a>
Philip Top	LLNL	<a href="mailto:top1@llnl.gov">top1@llnl.gov</a>
Chen Chen	ANL	<a href="mailto:morningchen@anl.gov">morningchen@anl.gov</a>
Venkat Krishnan	NREL	<a href="mailto:Venkat.Krishnan@nrel.gov">Venkat.Krishnan@nrel.gov</a>
YC Zhang	NREL	<a href="mailto:Yingchen.Zhang@nrel.gov">Yingchen.Zhang@nrel.gov</a>

Initially, the working group was asked to review and comment on the relevant section of the Technology Review and Assessment Report and thrust areas to become familiar with the current state of the art used in developing the initially proposed research thrusts within the Data Management area. The team was then asked to provide insights into potential gaps that exist in research and available technology and metrics for different topics areas. Team members were asked to identify not only gaps in the technology but also gaps in existing research to identify areas where additional research effort was warranted and would have the most impact.

### D.11.3 Key Findings and Recommendations

The team identified many key findings through subsequent discussions during the working group process, which resulted in the following recommendations concerning the data management area. What became clear through the process was that distinct metrics between evaluating the output of thrust areas and the prioritization of thrust areas were needed. Key findings include the following:

1. Much R&D is occurring at many institutions—commercial, educational, and government-sponsored—regarding data management and various technologies for dealing with data. Numerous technologies of various kinds were noted in the working group process. However, very little is making its way into power grid operation for three identified reasons:
  - a. Because there is no well-accepted way to quantify the benefits of data management technology, there is no way to justify the expense (initial and ongoing) to regulatory bodies and other stakeholders.
  - b. There is an educational gap in the electric utility space regarding data management practices and simple techniques and, in these institutions, there is a lack of the knowledge required to implement and maintain many potential solutions.
  - c. There are so many different quickly changing options for different technologies that in a slow-moving industry, it is impossible for a utility to keep up and maintain operations adequately. Some aspects are new and lack standards, and others have many competing standards. The effect is the same: there is no easy solution, so no solution is chosen.

***Federal research efforts in data management in the utility sector should specifically focus on addressing these three gaps: cost justification, workforce education, and standardization.***

2. It became evident in speaking with representatives of utilities and operators that one reason why operators are not using more advanced data and analytics for management of the grid is that the displays and indicators are not usable in the context of a grid control room. The displays and indicators too frequently require advanced understanding and in-depth study to understand and use. Plus, a utility operator needs an actionable decision from these data. This is reflective of the disconnect between researchers and operators about how humans operate in the control room environment. ***Federal research efforts in data management for visibility should focus on human-machine interactions with visualization. In addition, efforts to include operators much earlier in the development process and in partnership with researchers would be of great benefit to both sides.***

### D.11.4 Gap Analysis Summary

Gaps identified by working group	Relevant research thrust or thrusts	Approach to address gap	Key metrics to be addressed
There are no standard reliable and defensible ways to evaluate the value of data management systems to justify the initial and ongoing costs	?	Define a well-justified standardized way of determining the benefit gained from data management systems and technologies	Cost justification

Gaps identified by working group	Relevant research thrust or thrusts	Approach to address gap	Key metrics to be addressed
The data formats and standards used in collecting sensor data are not well accepted or interoperable	1,3	Establish best practice guidelines and testing measures for data management systems and develop data use standards per a GMLC consortium	Interoperability, cost, ease of maintenance
There is a lack of qualified personnel at many utilities to manage a complex data management system	?	Standardize tools and curriculum at the university level Make training courses easily available to the current workforce Reduce system complexity	Ease of use, cost
Compiled data and advanced analytics are not used or usable by operators	2	Establish collaboration between grid operators and researchers on displays and human machine interfaces to develop guidelines and standards for future displays and interfaces	Ease of use
Data are frequently siloed and not accessible by analytic tools that could make use of it	4, 5	Establish best practices, along with tools and technologies, for managing and interfacing large disparate data sets. Establish standards and technologies for appropriately distributing the data	Interoperability, Security, Extensibility, ease of use, cost

### Proposed Research Thrusts and Prioritization

Six research thrust areas were developed for consideration and discussion through the Roadmap development, along with three identified gaps or challenges that need to be addressed. Of these research thrusts, two are being recommended for prioritization as indicated. Descriptions of the research thrusts can be found in the document.

Research thrusts developed:

1. Data collection
2. Visualization and human interfaces (recommended)
3. Data access and interfaces (recommended)
4. Data organization
5. Data distribution
6. Online monitoring of distributed algorithms

Overall gaps:

1. Benefits quantification and justification
2. Lack of workforce
3. Standardization and long-term support

#### **D.11.5 Relation with Existing GMLC/GMI Efforts**

In some ways, the identified thrusts are research areas that are not well addressed by other GMLC projects or external entities, because that was one of the metrics for the gap analysis. Many of the topic areas covered under data management are being addressed in part in many of the projects throughout the GMLC. The Data Analytics project (1.4.9) interacts heavily with several thrust areas. In addition, many projects like Advanced Sensors Development, Data Analytics, and other projects related to modeling have a vested interest in standardization of interfaces and data access technologies. In a broad sense, the development of standards should be done as a consortium rather than through individual competing institutions. A standard developed by one or more institutions will not gain sufficient traction to have a rapid impact, whereas a standard developed by representatives from many labs and industry members might gain much faster acceptance. The GMLC can provide a framework to accomplish that aim.

## APPENDIX E. USE CASES

### E.1 USE CASE: FAULT DETECTION, INTERRUPTION AND SYSTEM RESTORATION

#### **Objective:**

Identify the optimal number and locations of fault detection and system restoration devices.

#### **Description:**

The protection systems for distribution systems were designed to detect and isolate faults locally and quickly to minimize the number of consumers impacted by faults. Fuses are used closest to consumer loads to protect consumer equipment from high fault current. The fault is isolated by the operation of the fuses (“melts”) closest to the fault. They provide an isolation measure for permanent faults, while reclosers at the distribution substation and along distribution circuits protect the circuits, circuit, or a section of the circuit and provide an isolation measure for both temporary and permanent faults. If the fault on the circuit is temporary, such as a tree limb brushing against an energized line, then the recloser should be able to clear the fault after one or two recloser operations (deenergize then reenergize the circuit during each operation). However, if the fault on the circuit is permanent, then the recloser stops trying to reclose into the faulted line after a set number of operations (e.g., two or three), and the faulted section is isolated from the rest of the circuit, allowing the unfaulted section of the circuit now isolated from the faulted section to be reenergized by the distribution circuit breaker or an upstream recloser. Since distribution systems were designed for one-way power flow, the introduction of distributed energy resources (DER) has an impact on existing protection approaches and systems.

The operation and protection of electric distribution systems is becoming more complex with the deployment of DER, energy storage, and responsive customer loads. The introduction and continued deployment of DER and storage introduces bi-directional power flow on these distribution circuits, and responsive customer loads change the demand of customer loads in response to utility signals or pricing. Thus, distributed resources can impact voltage profiles along with current flows on distribution systems/circuits and thereby impact protection devices and settings by their presence.

Fault detection, interruption and system restoration devices, such as the S&C Intellirupter, or other novel sensors and transducers, such as those being developed through the GMLC projects that employ both switchgear and control logic, are being deployed to provide more reliable power to distribution systems. They provide a means of rapidly detecting and interrupting faults and providing system restoration using intelligent detection and control logic and fault isolation switchgear. In the case of a temporary fault, the Intellirupter has only to detect and interrupt the fault until it dissipates and thus does not have to change the current substation feed for the distribution loads. However, in the case of a permanent fault, the Intellirupter not only detects and interrupts the fault but also may change the substation feed for loads downstream of the fault. There is no existing methodology for the deployment of these devices—only the rule-of-thumb methods used by engineers, such as the placement of two or more of these devices along distribution circuits. Plus, there isn’t an existing methodology for their placement to account for various levels of DER in the system, which can impact protection device locations and settings.

#### *Research Objectives:*

This proposed use case targets the following research objectives:

1. Develop a sensor optimization placement framework and tool for determining how fault detection, interruption, and system restoration devices, such as Intellirupters, should be placed to achieve optimal reliability performance on distribution systems both with and without DER.
2. Demonstrate this methodology using the electric power system model and other data from utility partners (e.g., Electric Power Board of Chattanooga [EPB], which has a fiber optics communication backbone in place from its earlier Smart Grid Investment Grant project).

### **Relationship with Proposed Focus Areas and Research Thrusts:**

Detecting and interrupting faults and the restoration of the power system are key to ensuring the reliability of smart distribution systems. The evolution of the smart grid, with the deployment of high penetration levels of DER, makes it more complex to maintain the high level of reliability that power systems currently have. Thus, it is critical that protection devices be both properly and adequately placed and that they allow for the adjustment of protection settings as the state of distribution circuits varies with the changing status of the DER on the circuit. Widespread deployment of these devices also requires advances in distributed communication architectures and efficient data management.

## **E.2 USE CASE: INCIPIENT FAILURE DETECTION IN ELECTRICAL GRID ASSETS**

### **Description:**

A common emerging theme throughout the development of the sensing and measurement technology roadmap has been the need for new sensing and measurement technologies that enable the detection and identification of incipient failures within the electrical grid infrastructure. The ultimate objective of early detection schemes is to provide utilities and other stakeholders with sufficient warning time and specificity regarding the failure mechanism to enable condition-based maintenance responses that prevent potentially disruptive, costly, and even catastrophic failures before they occur. A prominent example of critical grid assets for which incipient failure detection has a clear value proposition is large power transformers. Catastrophic transformer failures have large direct economic and social costs as well as major opportunity costs because of the long replacement times for these custom, bulky components with a highly constrained domestic manufacturing supply chain. For this reason, a range of commercially available sensors and diagnostics tools and methodologies have been successfully developed for both online and offline monitoring of large power transformers. However, the associated costs of existing commercial systems limit their deployment to power transformers large enough that the potential economic costs to the utility outweigh the costs of system installation, maintenance, and operation.

There is a clear value proposition for specific monitoring and measurement of the condition of large power transformers through techniques such as dissolved gas analysis. But distribution asset monitoring does not benefit from the economies of scale in the same way. Each component is a magnitude smaller at least; and for every large power transformer, there may be thousands of distribution-level transformers. At present, condition monitoring and maintenance in the distribution system is based upon a run-to-failure and age-based approach. Often, the first sign of a distribution transformer failure is an outage for a number of customers, detected via smart metering, or a customer call to indicate a component with a visible failure (e.g., smoke).

Emerging needs exist for new sensing and measurement technologies spanning devices, communications, and analytics to enable the successful realization of incipient failure detection schemes. There is also a need for associated condition-based maintenance programs ubiquitously throughout the electrical grid infrastructure, including but not limited to distribution systems and distribution-level assets. An increased reliance on advanced data analytics methodologies, as well as the development of low-cost,

multifunctional sensor devices compatible with deployment in electrical systems and assets, will play a key role in successfully realizing this objective.

*Research Objectives:*

This proposed use case targets two primary research objectives:

1. Develop and demonstrate novel data analytics methodologies that leverage existing and new sensing and measurement technologies for incipient failure detection at lower cost and higher fidelity than is currently possible with traditional large power transformer monitoring.
2. Develop and deploy new low-cost multifunctional sensor devices at a sufficiently low price point for incipient failure detection for distribution transformers and other grid assets such as energy storage devices. Existing sensing and diagnostic techniques are not yet widely deployed for these.

**Relationship with Proposed Focus Areas and Research Thrusts:**

Successful realization of widespread implementation of incipient failure detection schemes for electrical grid assets interfaces with a number of focus areas and research thrusts identified in the Roadmap. These span the areas of new sensor device development for asset health and functional performance monitoring, as well as advanced data analytics tool development and applications. Widespread deployment of low-cost sensor devices and data analytics algorithms will also require advances in distributed communication architectures and efficient management of large quantities of data in distributed network architectures.

**E.3 USE CASE: SENSING AND MEASUREMENT TECHNOLOGY TO MITIGATE AGAINST IMPACTS OF CYBER OR MAN-MADE ATTACKS**

**Description:**

Cyberattacks on critical infrastructure are increasing in number. Although most of the attacks have targeted only business networks, attacks on the Ukraine power grid in 2015 and 2016 demonstrated the reality of cyber-physical attacks on the grid resulting in load loss and widespread outages. Although no such attacks on the US grid have been successful yet, there is clear need to develop capabilities for timely cyber attack detection and mitigation.

A significant amount of both industry and government R&D has been invested in protecting the electricity transmission system. However, transmission substations are typically owned by utilities and have few or no constraints on cost, bandwidth, computing power, and quantities of data that can be collected and processed. On the other hand, given the high penetration of DER, and the proliferation of home automation and Internet of Things (IoT) devices, the distribution network is particularly vulnerable to cyberattacks. The attack surface is vast, and frequently security is not considered as part of the deployment and design of automation and IoT devices. The number of vendors providing the devices is very large, compared with the transmission system where a utility has control. The protection of these devices is typically left to the individual owners, creating an easy entry point for cyberattack vectors that can then propagate through these systems and cause upstream cascading effects. To contrast with transmission systems, DER have strict cost, bandwidth, computing, and data storage constraints. This situation drives a need to develop new sensing and analytics capabilities that will be specifically tailored to distribution systems. The main objective of these capabilities is to detect, isolate, and mitigate cyberattacks in early stages, before they propagate through the network or cause significant impacts to the larger system.

The development of new capabilities is necessary to understand what data are useful in enabling the detection of cyberattacks, understanding which parts of the system are and will be affected, and understanding how to best isolate and/or mitigate attacks. Ideally, these capabilities would be agnostic to the type of device or vendor and would have low overhead on the existing devices.

*Research Objectives:*

The proposed use case has the following objectives:

1. Develop and demonstrate low-cost sensing and analytics capabilities that will enable timely cyberattack detection on distribution systems before large-scale attack propagation and impacts occur.
2. Develop analytics capabilities able to distinguish between faults resulting from cyberattacks and regularly occurring faults.

**Relationship with Proposed Focus Areas and Research Thrusts:**

The use case interfaces with a number of focus areas and research thrusts identified in the Roadmap, including sensor devices, communications, and data management and analytics. It also involves the optimal sensor placement identified.

**E.4 USE CASE: INTEGRATING ADVANCED RESOURCE FORECASTS FOR TRANSMISSION AND DISTRIBUTION GRID OPERATION**

**Objective:**

Grid integration of advanced forecasts of variable renewable resources, including at the grid edge, for enhanced observability, lean reserve procurements in market operations, and improved grid flexibility.

**Description:**

Power system decision support tools, including market dispatch tools, energy management systems, and distribution management systems, need high-fidelity power forecasts under future scenarios with increasingly variable renewables. Currently, industry uses include forecasts on an hourly basis for day-ahead operation and 5 minute levels for real-time operation. But much needs to be achieved in terms of using the uncertainty information of the mean forecasts (such as probabilistic forecasts), which can be extremely valuable in forecasting net-load uncertainties and, consequently, reserves and ramping product requirements in day-ahead and real-time operation. Additionally, current spinning and nonspinning reserves procurement for contingencies uses *ex ante* preventive planning. But having low-latency, highly accurate real-time forecasts will enable the procurement of reserves as a corrective paradigm using the latest forecasts after a severe contingency event. This will allow for further reduction in reserves procurement and the related costs.

Integrating advanced forecasts into market operations will also pave the way for using variable renewables for grid flexibility. Generally, flexible conventional generation, such as gas units, is thought of as a solution to mitigate the uncertainties caused by variable (in terms of power output) renewables. But highly accurate, low-latency forecasts can enable renewables to be part of the solution for flexibility rather than a problem.

Another challenge is to integrate better forecasts of grid-edge solar resources and, consequently, to estimate the net load at the feeder head accurately. This will enhance the visibility of the grid states for

the purposes of better distribution grid management, accurate fault identification, and voltage control, as well as economic procurement of reserves to mitigate uncertainties arising from the distributed solar photovoltaic (PV) resources.

### **Relationship with Proposed Focus Areas and Research Thrusts:**

Demonstrations are needed to show the impact and value proposition of advanced forecast integration into independent system operator and utility operations. Synergistic coordination of variable renewables with demand response and storage technologies can be studied from such a use case demonstration. This use case targets not just the distribution grid but the entire transmission and distribution grid for efficient integration of weather sensing devices and their data. As more integration efforts are carried out across the continental United States, there will be more need for disparate high-resolution weather data access, data quality control, and standardization.

The value of this use case can be estimated in terms of grid economics, flexibility, reliability, and resilience under extreme events. Additionally, the synergies between weather and grid sensors can be studied to explore the value of replacing other expensive grid sensors, such as phasor measurement units, with the available low-cost weather sensing systems and their forecasts.

## **E.5 USE CASE: TOPOLOGY DETECTION WITHIN THE DISTRIBUTION SYSTEM**

### **Description:**

This use case considers sensing, measurement, and analytics technologies that enable the detection, reconstruction, and identification of topology within the electrical grid infrastructure. Topology in itself deals with the configuration, phase, and status of switches, loads, breakers, and substations.

As customer-side technologies become a common part of the grid landscape, and distributed controls become prevalent, it is becoming critical for utilities to understand the electrical connectivity of components to ensure that sufficient visibility and control can be maintained over these highly dispersed variable components. Ubiquitous sensing and measurement in themselves are not sufficient to identify all potential configurations without the coupling of analytics and interpretative technologies.

Topology identification will provide utilities with an accurate picture of the configuration of the grid and the load that it serves at any given time. Typically, at the distribution level, topology is corrected or analyzed through the existing utility geographical information system (GIS). From the geographical models, electrical model updates are extracted, which should account for the most recent changes to the power system. Herein lies the difficulty of ensuring an accurate representation of system changes. Without direct sensing and measurement of a particular topology change or manual input of a change due to switching operations, the system model will be inherently error prone. Typical methods of GIS correction include manual inspection—a time-consuming, and often impossible process, especially in urban areas or in an automated system scenario. The building level-topology is often completely unknown to the utility, and the low-voltage network is not commonly modeled in the GIS.

Topology can be identified through specific sensing and measurement on each switch or device capable of changing the topology. In high-voltage transmission scenarios where switching is automated, this is essential for control. At the distribution and building levels, there is presently little cost benefit to individual sensing of all topologies. In addition, the sensing of each topology change at these two levels in itself does not provide a reconstructed singular picture of topology. Sensing must be parsed with analytics to enable full visualization to be realized. Building controls and advanced electric distribution management system functions with DER require accurate and reliable distribution system modeling,

monitoring, and coordination. Topology reconstruction and learning of electrical connectivity will enable accurate, local service provision.

Learning the topology of the distribution grid from measurements is an essential precursor for multiple distributed tasks related to economic activities of aggregators, as well as safety monitoring and distributed control to guarantee safe operations. A key to grid resilience is knowing what resources are available and where those resources are electrically with reference to grid topology. This process requires a multi-redundant, robust, decentralized approach. Decentralization with links to a higher-level hierarchy is key to a fast recovery. Learning of grid topology requires that systems be modeled on a time scale. Machine learning-based analytics would support each area of grid modernization by using this growing volume of data to improve the detection of normally invisible phenomena, learn grid topology, and support security applications, including detection of physical or cyber-based attacks.

#### *Research Objectives:*

The proposed use case targets two primary research objectives:

1. Develop and demonstrate novel data analytics methodologies that leverage existing sensing and measurement technologies for accurate topology detection.
2. Integrate advanced analytics with simulation and utility and building advanced distribution management systems.

#### **Relationship with Proposed Focus Areas and Research Thrusts:**

The successful realization of widespread implementation of topology identification schemes for electrical grid assets interfaces with a number of focus areas and research thrusts identified in the Roadmap for advanced data analytics tool development and applications. Widespread deployment of low-cost sensor devices and data analytics algorithms will also require advances in distributed communication architectures and efficient management of large quantities of data in distributed network architectures.

Solving these problems practically (designing scalable algorithms) will require trade-offs among many elements. These include complete vs. model-reduced (coarse-grained) descriptions, centralized vs. distributed approaches in terms of both measurements and controls, and physics-intense (equation-based) and physics-blind (equation-free) machine learning (inverse problems) approaches and techniques. Useful topology identification requires the development of practical solutions and compromises for placing measurement and control devices and storing and using the appropriate amount of data.

### **E.6 USE CASE: SENSING AND MEASUREMENT TECHNOLOGY TO MITIGATE AGAINST IMPACTS OF NATURAL DISASTERS AND ENHANCE GRID RESILIENCE**

#### **Description:**

Recent severe power outages caused by extreme weather hazards have highlighted the importance and urgency of improving the resilience of the electric power grid. For example, Superstorm Sandy in 2012 left more than 8 million customers without power across 15 states and Washington DC on the east coast of the United States. It is estimated that the inflation-adjusted cost of weather-related outages in the United States is \$25 to \$70 billion annually. On the one hand, the current electric distribution grids remain vulnerable to extreme weather events. On the other hand, customers' expectations for the continuity of electricity services have increased with the evolution of modern society's reliance on

electricity. To enhance grid resiliency against natural disasters, the power industry focuses on improving the distribution system restoration in a more quick and efficient way.

One big challenge for distribution system restoration in natural disasters is the lack of situational awareness regarding the damage status of the distribution grid. The current practice still mostly relies on damage assessors to patrol the feeders to identify trouble spots and evaluate the extent of damage, which is a very slow process and is based on which restoration efforts can be coordinated. In addition, most current distribution systems are “blind” in terms of monitoring and control capability beyond the distribution substation. Even if some observability is enabled by automated meter reading information or distribution automation, measurement data after a natural disaster may be unavailable or questionable because the devices as well as the underlying communication network may also be damaged. To pinpoint the faulted areas, the current outage management systems usually depend on customer trouble calls, which are slow and inaccurate. Furthermore, the data silos among different data sources impact the ability to achieve situational awareness in a timely manner.

The development of sensing and measurement technology has the potential to improve the situational awareness of the grid before and after natural disasters and thus can improve the distribution restoration practice for utilities. For example, from the device-level perspective, the development of low-cost sensors to monitor asset statuses (e.g., via asset monitoring sensors) as well as grid condition (e.g., smart meters, phasor measurement units, distribution automation sensors) could provide additional vision for estimating damage status and increase redundancy to achieve observability under severe conditions. From the communication-level perspective, the development of a distributed communication architecture as well as an associated self-healing mechanism could achieve resilient communication to mitigate the impact of infrastructure damage due to natural disasters. From the data management and analytics perspective, the development of advanced data management techniques could enable the efficient integration of multiple data sources from different types of sensors to improve grid situational awareness. The development of data analytics methods to estimate the damage status could be robust against missing or erroneous measurement data due to the impact of natural disasters.

#### *Research Objectives:*

This proposed use case targets research objectives as follows:

1. Develop and deploy low-cost sensor devices that could provide observability of asset statuses as well as grid condition. Their ability to withstand the disaster would be an advantage.
2. Develop optimal sensor placement strategies to ensure a certain level of redundancy for observability under severe conditions.
3. Develop distributed communication architectures with functionality that does not rely on infrastructure availability and can provide dynamic networking features, which are resilient to natural disasters.
4. Develop a self-healing mechanism to recover a certain level of communication to mitigate the impact of damages.
5. Develop data management schemes to achieve efficient integration of multiple sources of sensor information to enhance damage assessment
6. Develop robust data analytics methods that provide viable damage assessment results when data quality is significantly impacted by natural disasters (e.g., erroneous data or missing data).

### **Relationship with Proposed Focus Areas and Research Thrusts:**

The use case interfaces with a number of focus areas and research thrusts identified in the Roadmap, including sensor devices, communications, and data management and analytics. It also involves the optimal sensor placement identified in the roadmap.

### **E.7 USE CASE: OPTIMIZING GRID OPERATION WITH ENHANCED DATA SPANNING TRANSMISSION DISTRIBUTION AND GENERATION**

#### **Objective:**

Develop sensing, data analytics, and communication infrastructure for achieving generation, transmission, and distribution (G, T, and D) operation with a high penetration of distributed resources

#### **Description:**

Electric power systems are becoming more complex with the deployment of DER, storage, and responsive customer loads. The majority of electric distribution systems have traditionally been designed and operated as radial systems providing one-way power flow, whereas transmission systems have been designed for networks and two-way power flow. In the case of distribution systems, the introduction and continued deployment of DER and energy storage introduces bidirectional power flow on these distribution circuits. Responsive customer loads change the demand of customer loads in response to utility signals or pricing. In the case of transmission systems, transmission lines provide the vital link between generation and distribution systems. The introduction of greater renewable energy sources on transmission systems results in utilities needing to rely more on firm power sources and responsive industrial loads when there is insufficient solar or wind power to provide renewable energy. Furthermore, DER can impact operating voltage profiles and reactive power requirements as well as protection schemes. Additionally, with increased variable renewable penetration at both transmission and distribution levels, grid stability assessments need to be performed faster in an online fashion. Offline simulations and machine learning techniques applied to new sensor data can enable the application of stability assessments and indices in real time. There is increased need to use model-free methods that directly use data from sensors to learn system stability and perform timely control actions.

#### *Research Objectives:*

This proposed use case targets the following research objectives:

1. Develop sensor and data analytics needed to achieve high DER penetration on a power transmission and distribution system. Work with a distribution system utility to understand the needs to achieve this within a particular system.
2. Develop sensor and data analytics needed for future system operation with high DER penetration on both the transmission and distribution levels.
3. Develop theoretical foundations and research demonstrations for autonomous energy grids that will use heterogeneous sensor data proliferated in transmission and distribution grids and will perform real-time data-driven stability assessments and optimal control for ensuring reliability and economics.

## **Relationship with Proposed Focus Areas and Research Thrusts:**

A future challenge for the modern grid is understanding the tolerance of existing transmission and distribution systems for accepting high levels of DER penetration. This area involves greater need not only for sensors but also for data analytics, communications, controls, and protection. As the modern grid evolves, new design changes in the transmission and distribution systems may alleviate some of these needs, but there will also be legacy systems to accommodate.

### **E.8 USE CASE: DETECTION OF ENERGY THEFT AND UNREGISTERED DER**

#### **Objective:**

Detect rogue DER, identification/development of low-cost sensor technology, and data analytics for detection of energy losses due to energy theft on power systems.

#### **Description:**

The deployment of DER is occurring with the placement of PV and wind systems on transmission and distribution systems. Large DER systems, e.g., 1 MW or larger, are being developed and deployed by commercial entities and are regulated by the respective utility systems to which they provide renewable power. However, in the case of residential-sized DER, not all of these sources are registered with the utility system, especially when the source is installed behind the customer kWh meter. In the case of a DER deployed at an existing home that has been without this energy source initially over a period of time, it may be possible to detect the presence of the DER by detecting the decrease in energy demand. However, there may be a need for better detection of these rogue distributed sources. In fact, the goal is to be able to both detect a source and its output not only to forecast the capability of these sources but also to determine how to control voltage regulators, capacitor banks, and reactive power sources to ensure the correct regulation of voltage profiles and overall power factor on distribution systems/lines.

In the case of the EPB, one of 152 power distributors of the Tennessee Valley Authority, the utility not only must maintain the distribution system voltages of its secondary within an adequate operating range to maintain  $120\text{ V} \pm 5\%$ , but also must maintain its aggregated power factor level within an adequate operating range, such as 0.95 leading to 0.95 lagging. Traditionally, EPB has been able to meet these requirements using its load-tap-changing transformers and capacitors banks at EPB distribution substations and line voltage regulators on their distribution circuits. However, the growing number and capacity of DER on distribution circuits introduces more of a challenge for voltage regulation and reactive power support. One of the key challenges is the need for adjustable settings for line regulators to compensate for the presence of DER. The introduction of smart meters and telemetry has enabled distribution systems to better monitor their energy loads and detect energy losses. However, unregistered distributed sources make it difficult to determine the difference between reduced energy load and losses, especially energy theft.

#### *Research Objectives:*

The proposed use case targets four primary research objectives:

1. Develop and demonstrate low-cost sensing of previously unknown DER on distribution circuits.
2. Demonstrate this technology (e.g., on the EPB system) and adjust line voltage regulator settings via telemetry in response to changing operating states of DER in the distribution system.

3. Develop analytical methods to determine the true generating behavior of behind-the-meter resources from electrical parameter measurements.
4. Develop low-cost sensing technologies and data analytics that leverage existing sensing and measurement technologies and advanced data analytic methods for detecting energy losses due to theft.

**Relationship with Proposed Focus Areas and Research Thrusts:**

The detection of energy theft is not an area restricted to developing countries only. The evolution of the smart grid with the deployment of DER makes it more difficult for distribution systems to detect energy losses due to power transmission versus those due to energy theft by actors unlawfully tapping into distribution systems.

Successful detection of previously unknown DER in distribution systems interfaces with a number of focus areas and research thrusts identified in the Roadmap. They span the areas of new sensor device development, data analytics, and communications systems, as well as control development and applications. The need for this sensing capability also interfaces with the development of the sensor optimization placement tool (SPOT) to provide optimal placement for detection and accommodation of DER.



---

**U.S. Department of Energy**  
**National Energy Technology Laboratory**  
626 Cochran's Mill Road  
P.O. Box 10940  
Pittsburgh, PA 15236-0940  
412-386-4984

<http://gridmodernization.labworks.org/>